

Digital Pressure Measurement

Features

- Intelligent pressure modules
- Ethernet TCP/IP Protocol “Network Ready”
- 0 - 750 psi pressure range
- Temperature compensated pressure sensors
- Dual pressure ranges available
- $\pm .05\%$ full scale long term accuracy
- Time stamped data available
- 500 samples/channel/second EU



DSA3217 (Shown)

General Description

The DSA3200 series pressure acquisition systems represent the next generation of multi-point electronic pressure scanning. Model DSA3217/3218, Digital Sensor Array, incorporates 16 temperature compensated piezoresistive pressure sensors with a pneumatic calibration valve, RAM, 16 bit A/D converter, and a microprocessor in a compact self-contained module. The result is a network ready intelligent pressure scanning module.

The microprocessor compensates for temperature changes and performs engineering unit conversion. The microprocessor also controls the actuation of an internal calibration valve to perform on-line zero and multipoint calibrations. This on-line calibration capability virtually eliminates sensor thermal errors with a long term system accuracy of $\pm .05\%$ FS.

Pressure data are output in engineering units via Ethernet using TCP/IP protocol.

Scanivalve offers an optional multi-range calibration. This allows the DSA modules to have multiple pressure ranges. The calibration valve and transducers are manifolded in groups of 8. The user can specify up to 3 pressure ranges within that group of 8 as long as the ratio for all 3 full scale ranges doesn't exceed 3:1 from highest to lowest range.

Applications

The DSA3217/3218 Digital Sensor Array is ideal for flight and turbine engine testing applications, where ambient temperatures vary. It is also ideal for industrial pressure measurement where long calibration intervals are required or temperatures can vary greatly. The DSA temperature compensated pressure sensors are more than ten times less sensitive to temperature than typical piezoresistive pressure sensors. They are not attitude sensitive, so the units may be close coupled to the pressure sources to be measured.

When further temperature stability is required or for use below 0°C , it is recommended that the Model DSA3218 be used. The Model DSA3218 is basically a DSA3217 installed in an insulated, environmental box. All Px input and control pressure fittings are 1/8 inch Swagelok[®] fittings. Optional DSA3218 fittings are 1/16 and 1/4 inch Swagelok[®] fittings.

DSA[®] is a registered trademark of Scanivalve Corp. Windows[®] and MS-DOS[®] are registered trademarks of Microsoft Corp.

VEE[®] is a registered trademark of Agilent.

LabVIEW[®] is a registered trademark of National Instruments.

Swagelok[®] is a registered trademark of Swagelok Corp.

DSA3217/3218 Features/Options

DSA Calibration Valve

The DSA3217/3218 calibration valve is “Normally Px” where no control pressures or a loss of control pressure defaults the valve to the operate (sense) mode. 90 psi control pressure is required to switch the DSA calibration valve into purge, calibrate or isolate mode. This calibration valve allows the DSA sensors to be automatically calibrated on-line with either a zero or multipoint calibration.

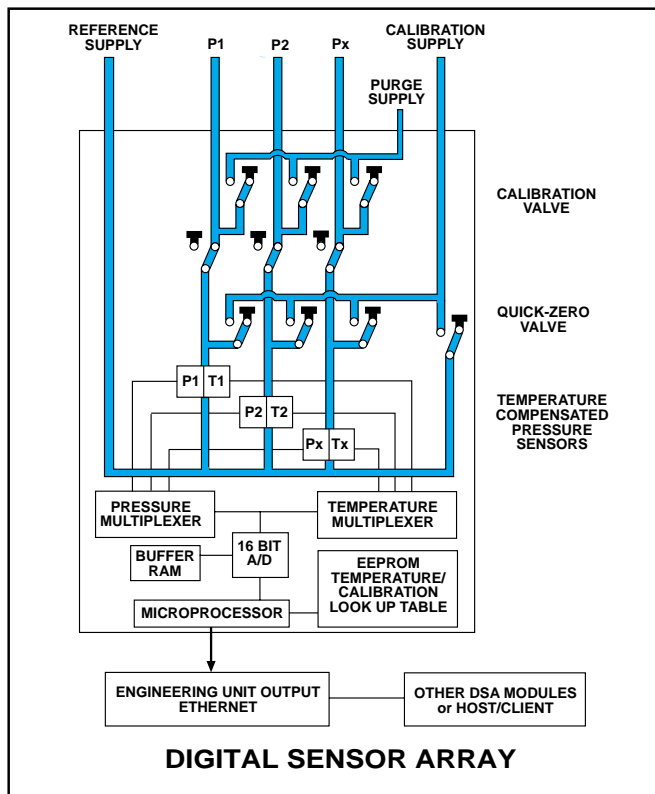

On-Line Sensor Compensation and Calibration

An internal solenoid valve is utilized for performing quick zero calibrations without the use of a pressure calibrator. When actuated, the positive side of the pressure sensor is pneumatically shorted to the reference manifold, creating a zero differential. The sensor offsets are then updated and saved in EEPROM.

Each DSA3217/3218 silicon pressure sensor is thermally compensated and packaged in its own rugged field-replaceable housing. The transducers are factory calibrated over their full pressure and temperature ranges. The resultant calibration data are stored in a 60 plane pressure/temperature look-up table in EEPROM.

As the sensed sensor bridge temperature changes, the microprocessor selects the appropriate temperature plane or interpolates between planes to correct the pressure reading. This on-line temperature correction and quick zero calibration corrects for inherent zero drift and temperature sensitivity, thus assuring a long-term 6 month accuracy of $\pm 0.05\%FS$.

DSA Network Addressing

Each DSA module has a unique, factory set MAC address. When running TCP/IP protocol, the DSA modules support ARP (Address Resolution Protocol) to enable the client/host to determine the relationship between the IP address and the MAC address. The IP address is user assignable.

All scan and calibration variables are configured through software by the user. This includes number of frames/scan, number of averages per frame, sampling speed, etc.

The DSA module may be tested through the Ethernet port. These tests include the ability to scan raw counts, calibrate the A/D converter, measure the sensor temperature, and zero drift.

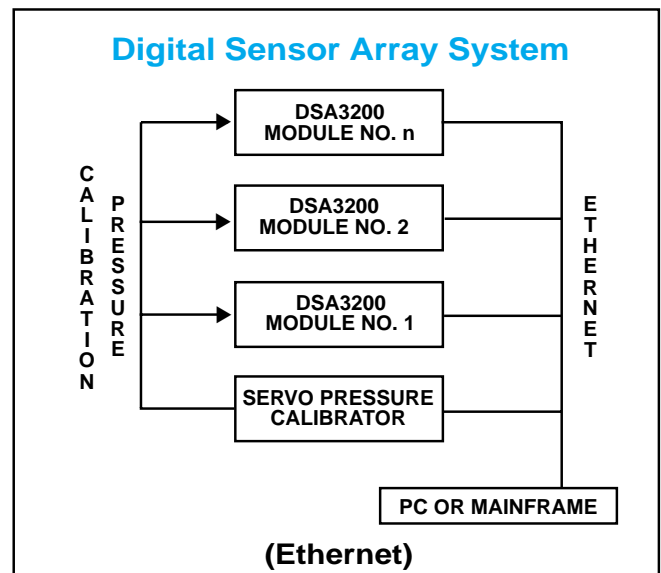

DSA[®]3200 System / Specifications

DSA3200 System Network

The DSA3217/3218 module interfaces directly to a PC, host computer, or Ethernet network. Up to 1024 nodes (DSA or DEI modules, or third party devices) may be connected on one network.

A Windows[®] based communication program, DSALINK2 is available from Scanivalve. It allows

menu driven communication for easy startup with the DSA3200 series module via TCP/IP. Telnet communication is easy with ASCII commands. Optional LabVIEW[®] or Agilent's VEE[®] software provides graphical data display and coordinates other utility programs. An OPC driver is also available.

Specifications

Inputs (Px):

DSA3217: Standard: 16 each .063 inch (1.6mm) O.D. tubulations
 DSA3218: Standard: 1/8 inch Swagelok[®] fittings
 Optional: 1/16 and 1/4 inch Swagelok[®] fittings

Full Scale Ranges:

Differential: ±10 inch H₂O, 1, 2.5, 5, 15, 30, 50, 100, 250, 500, 750 psid
 Absolute: 15, 30, 50, and 100 psia

Accuracy:
 (Including linearity, hysteresis, and repeatability)

Sensor Pressure Range	Static Accuracy (% F.S.)
±10 inch H ₂ O (2.5 kPa)	±.20%
±1, ±2.5 psid	±.12%
±5 to 500 psid	±.05%
±501 to 750 psid	±.08%

Resolution: 16 bit
Scan Rate: 500 Hz/Channel EU
Communication: Ethernet 10baseT
Communication Protocol: TCP/IP or UDP
Operating Temperature: DSA3217: 0°C to 60°C
 DSA3218: 0°C to 55°C below 0°C, specify heater above +55°C, specify cooling kit
Temperature Compensated Range: 0°C to 60°C standard

Mating Connector Type:

I/O: PTO6A-8-4S-SR
 Power: Bendix PTO6A-8-3S-SR, 3 pin female
 Trigger: Bendix PTO6A-8-2S-SR, 2 pin female

Power Requirements:

DSA3217: 28Vdc nominal @ 400mA (20-36Vdc)
 DSA3218: (w/Heater) 28Vdc nominal @ 1.25A (24-36Vdc)
 DSA3218: (w/o Heater) 28Vdc nominal @ 400mA

External Trigger:

6 mA at 4 Vdc minimum edge sensing

Overpressure Capability:

10 inch H₂O = 2 psi (13.79kPa)
 1 psi = 5 psi (35kPa)
 200 psi (1379kPa) = 200%
 500 psi (3447kPa) = 150%
 600 psi (4137kPa) = 125%
 750 psi (5171kPa) = 100%

Maximum Reference Pressure:

250 psig (1724kPa)
 (Consult factory for higher reference pressures)

Media Compatibility:

Gases compatible with silicon, silicone, aluminum, and Buna-N

Weight:

DSA3217/16Px: 6.4 lbs. (2.9 kg)
 DSA3218/16Px: 9.8 lbs. (4.45 kg)

Total Thermal Error over 0 - 60°C Range:

±.001% F.S./°C

Ordering Information

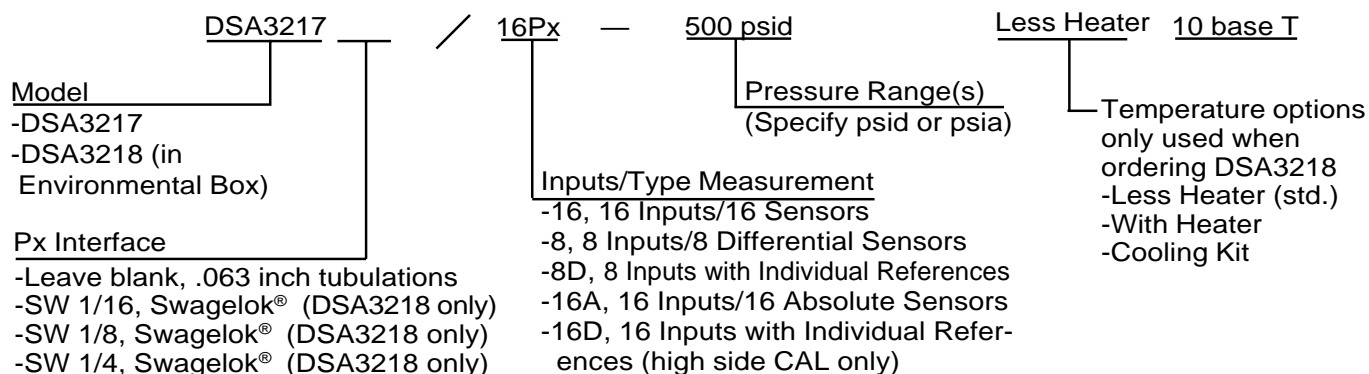

DSA® Dimensions

Dimensions Inches (mm)

DSA3217/16 Px

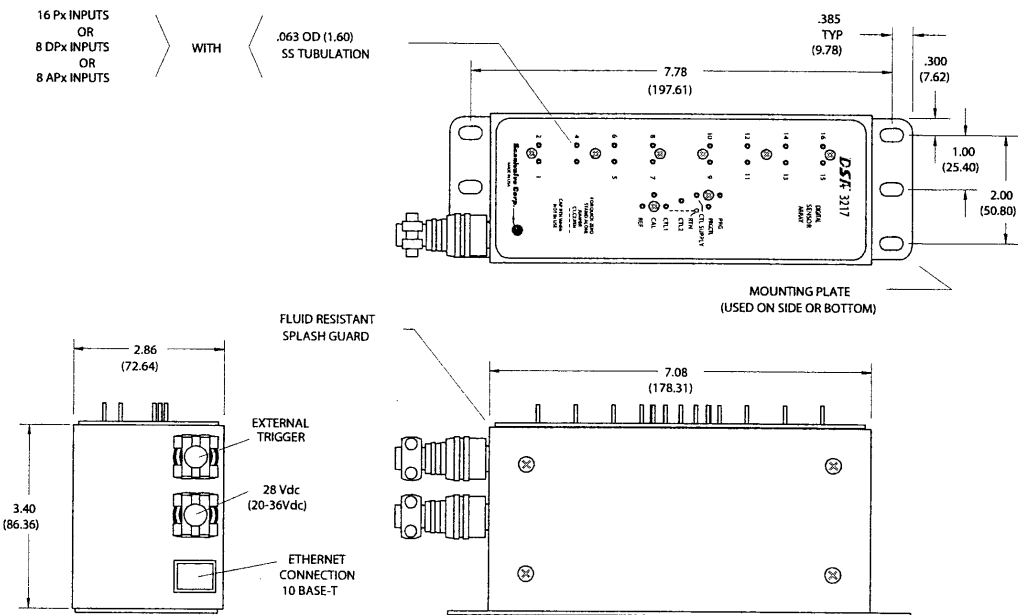

DSA3218/16Px in an Environmental Box

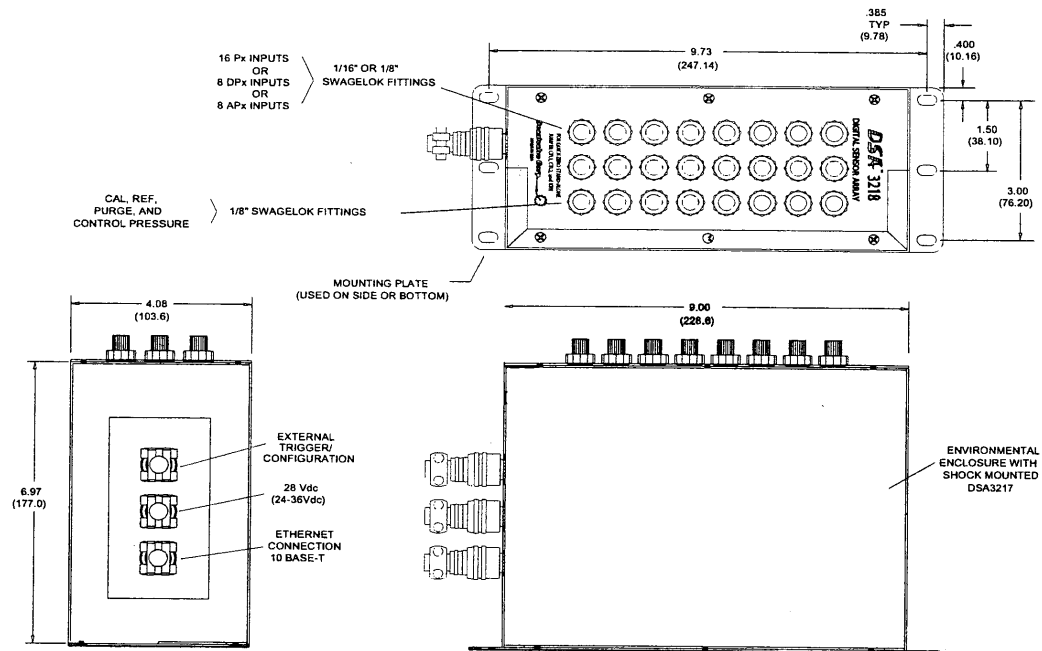

*Each DSA module comes with the mating trigger and power connector. Ethernet connector comes with DSA3218 module only.

0311-2003



ALTHEN GmbH Meß- und Sensortechnik

Frankfurter Straße 150 – 152

D-65779 Kelkheim/Germany

+49 (0) 61 95/70 06-0

+49 (0) 61 95/70 06-66

<http://www.althen.de>

verkauf@althen.de

