

Omniprobe

Engineering
Flow-Measurement
Solutions

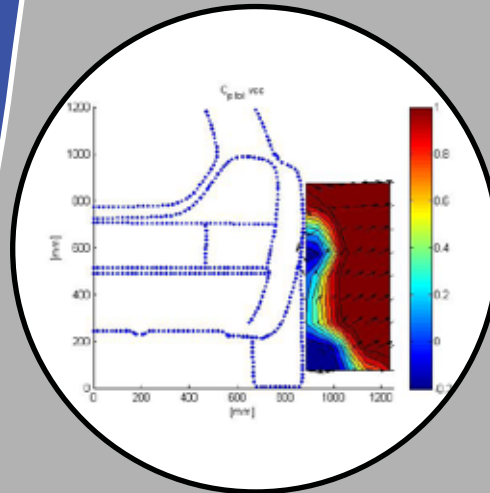

A
E
R
O
D
Y
N
A
M
I
C
S

Omniprobe



L-shaped Omniprobe

Applications:

- Determination of Three Components of Flow Velocity Plus Total and Static Pressure at Probe Tip
- Accurate Resolution of Velocity Vectors as High as 165° from Probe Axis
- Measurement of Reversed Flows
- Measurement of Time-Averaged Flows, Typical. Calibrated Frequency Response up to 500 Hz Possible, Depending on Pressure Sensors and Tubing Connections
- Flow Speeds from 5 m/s to 325 m/s, Mach 0.02 to Mach 0.95. Mach 0.02 – 0.3 Recommended for Best Performance

Features:

Omniprobe:

- Spherical Tip with 12 Pressure Ports
- Standard Omniprobe Tip Diameter of 9.52 mm, with 6.35 mm Standard Option
- Multiple Standard Probe Geometries

- Rugged Construction using Stainless Steel
- Aeroprobe Expertise in Omniprobe Design and Construction
- High-Accuracy, 7000+ Point Aerodynamic Calibrations
- Long Intervals Between Aerodynamic Calibrations under Normal Usage

Omniprobe Pressure-to-Velocity Reduction Software

- High-Accuracy Reduction with Local-Least Square (LLS) Method
- Max Errors of 2% in Velocity Magnitude, 1.5° in Flow Angles
- Multi-Region Searching Algorithm for Sector Boundary Points

Introduction:

Standard multi-hole probes are restricted to flow measurements where the velocity vector made an angle of 70° (or less) with the probe axis (see Aeroprobe product information for 5-hole and 7-hole



Aeroprobe
CORPORATION

Straight Omniprobe

multi-hole probes). The introduction of the omniprobe represented a vast improvement with regards to the angular resolution of multi-hole probes. By employing 12 pressure ports distributed on the surface of a spherical surface, the omniprobe can accurately measure flows from virtually any direction. Like the traditional multi-hole probes, data acquisition with the omniprobe requires (1) the probe itself, (2) an accurate aerodynamic probe calibration, (3) pressure sensors and data acquisition in order to measure the probe port pressures and (4) a pressure-to-velocity reduction method based on the calibration. This document gives product information for (1), (2) and (4) above.

Omniprobe:

Standard Omniprobe:

Aeroprobe offers two standard omniprobe geometries: straight and L-shaped. Standard construction material is stainless steel.

Standard omniprobes have a 9.53 mm tip diameter, and a 152.4 mm overall length. The hex mount is 9.53 mm flat-to-flat. The exit tubing for pressure connections is 1.07 mm in diameter, 44.5 mm in

length and is stainless steel. The standard probes are shown in Figure 1. Geometrically similar probes are available with a tip diameter of 6.35 mm.

All standard omniprobes are supplied with one calibration at a requested speed. Additional calibrations at other speeds may be specified on order. Custom omniprobes are normally supplied with a full calibration, unless this is precluded by geometry restrictions.

The advantage of using an omniprobe rather than a traditional five- or seven-hole probe is the angular resolution capability. Seven-hole probes are highly accurate until the velocity vector reaches a total angle of about 70° with respect to the flow. For five-hole probes this angle is about 60° . Omniprobes are able to resolve velocity vectors having angles of up to 165° with the probe axis (relative to base-to-tip direction). This allows the omniprobe to measure flows with very high angularity and even reversed flows.

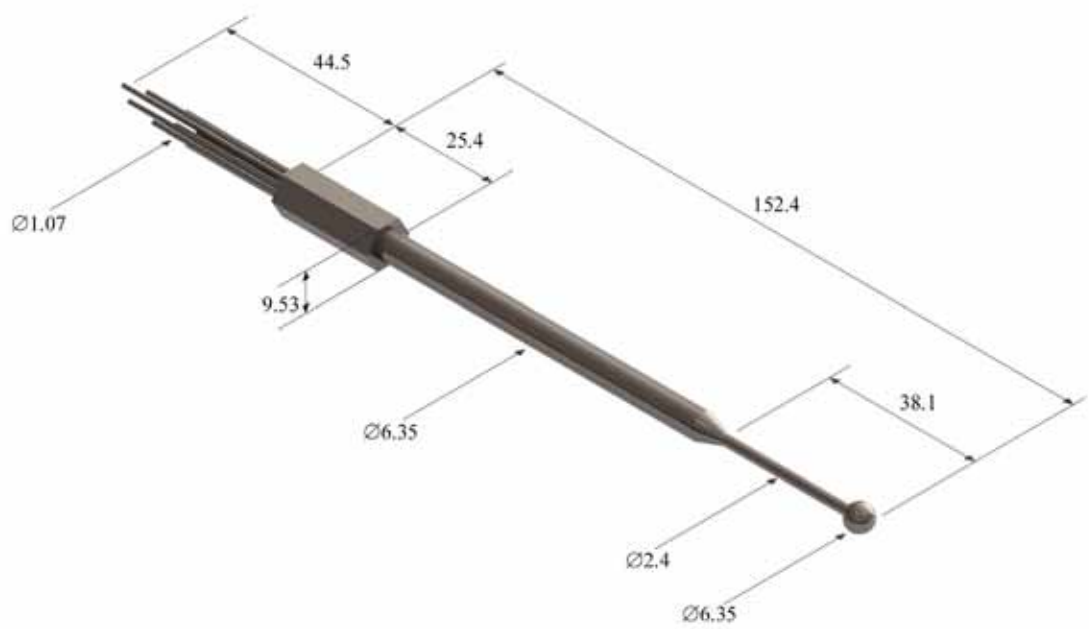
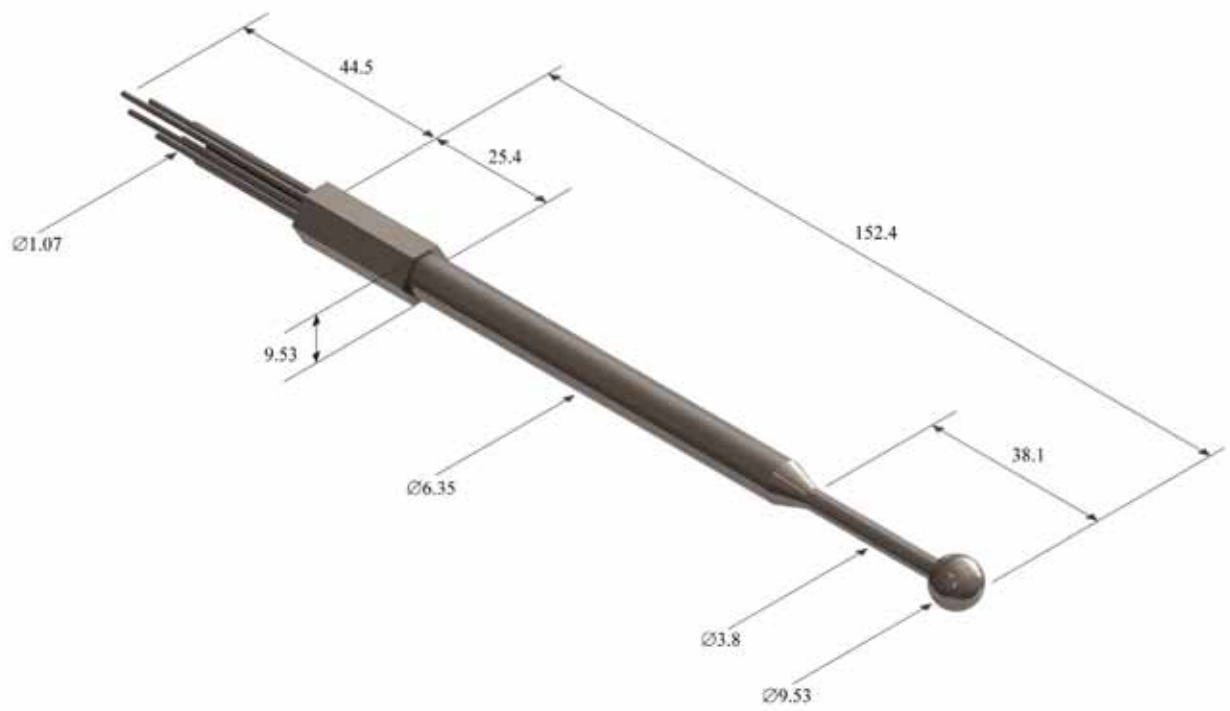

Aeroprobe
CORPORATION

Figure 1(a): Standard Straight Omniprobes. All Dimensions in Millimeters.

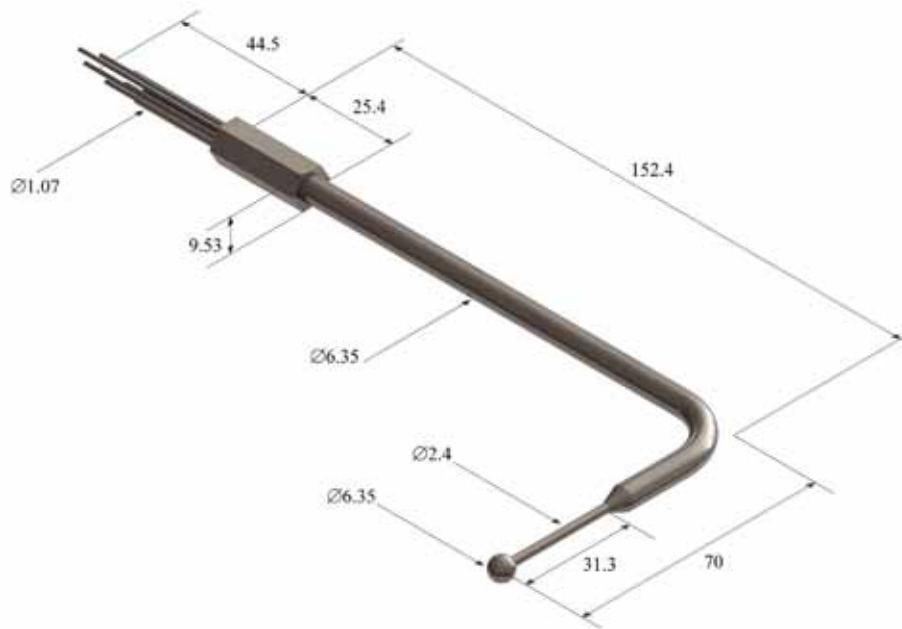
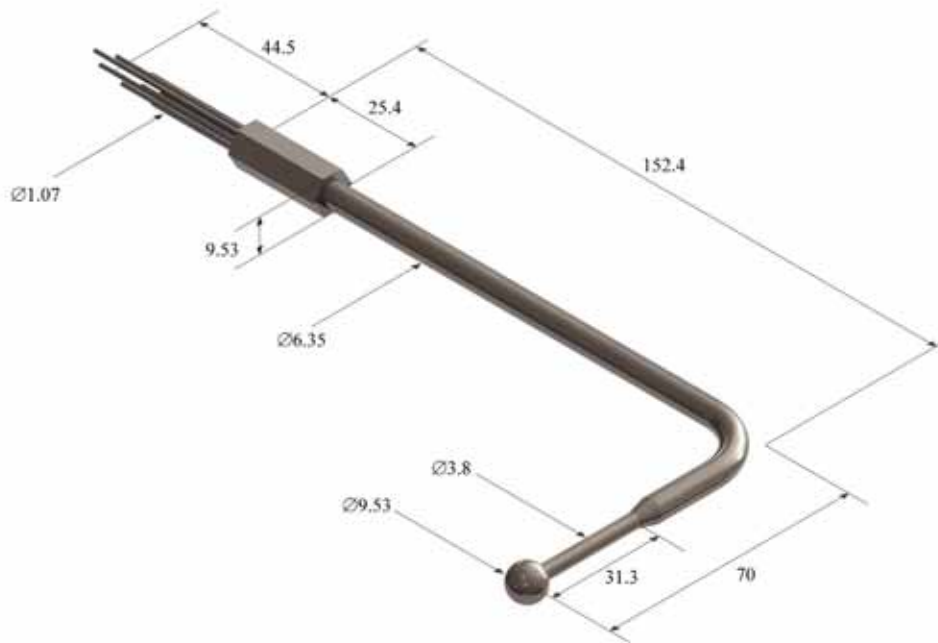

Aeroprobe
CORPORATION

Figure 1(b): Standard L-Shaped Omniprobe. All Dimensions in Millimeters



Straight



"L" Shaped

Aeroprobe
CORPORATION

Figure 2: Probe Design and Specification

Table 1: Probe Design and Specification

Geometry Codes			Probe Type			Tip Geometry	
D	Tip Diameter		S	Straight		S	Spherical
L	Overall Length		L	L-Shaped			
T	Probe Tip Length						

Omniprobe Model Number Definition	
P or CP	P = Standard Probe CP = Custom Probe
Probe Type	Straight or L-Shaped See Codes Above
H	Number of Probe Ports = 12 or 18
-	
Tip Geometry	Spherical = S
D	Tip Diameter in Hundredths of a Millimeter (Three Digits)
-	
L	Overall Length of Probe in Millimeters (Three Digits)
-	
T	Length of Probe Tip in Millimeters (Three Digits)
<i>Note: T is used only if Required, Omitted Otherwise</i>	

Standard Omniprobe Options

Standard omniprobe options include reduction of tip diameter to 6.35 mm.

Custom Omniprobes

Aeroprobe would be happy to consider your requests for custom omniprobes. Each probe is essentially designated by specifying the geometry fields, as shown in Figure 2. Some minor geometry changes from the standard probes (including, but not limited to, increased/decreased length and increased tip lengths on L-shaped omniprobes) can be easily accommodated. Typical custom geometry ranges are

given in Table 1, and probes with parameters within these ranges will have minimized customization costs. Please note the restrictions on bend radii in Table 2 and standard tolerances in Table 3.

Examples:

PL12-S953-152-070 specifies a standard 12-hole L-shaped omniprobe with a 9.53 mm tip diameter, 152 mm overall length and a 70 mm tip length.

CPS18-S635-255 specifies a custom straight 18-hole omniprobe with a 6.35 mm tip diameter and 255 mm overall length.

Table 2: Acceptable Geometry Limitations for Omniprobes ¹:

Dimension	Minimum (mm)	Maximum (mm)
Tip Diameter (D)	6.35 mm	9.53 mm
Overall Length (L)	102 mm	255 mm
Tip Length (T)	70 mm	102 mm

¹ Probes complying with these geometry ranges will have minimized customization costs.

Table 3: Minimum Bend Radii (Centerline)

Shaft Diameter (mm)	Minimum Bend Radius (mm)
6.35	15.88

Table 4: Standard Tolerances ¹:

Dimension or Component	Tolerance
Tip Diameter and Exit Tubes	±0.05 mm
Other Diameters (Housing Tubes):	±0.1 mm
Locations (Centerlines, Ports):	±0.0508 mm, worst case
Primary Lengths (Overall Length, Exit Tubes, Hex Mount, Ferrules):	±2.54 mm
Other Lengths (Bent Leg, Housing Stages)	±5.1 mm
Included Tip Angle (Conical):	±0.5°
On-Axis Bend Angle:	±1°
Off-Axis Bend Angle:	±5°

Omniprobe Calibrations

The probe calibration is essential to proper operation of the probe. It defines a relationship between the measured probe port pressures and the actual velocity vector.

The omniprobe calibration process consists of placing the probe in a uniform, known flowfield (known in terms of velocity magnitude and direction, density, temperature, static pressure), and then rotating the omniprobe to over 7000 different orientations with respect to the known velocity vector. The probe tip is maintained at the same physical location during the entire calibration process. At each orientation, the probe port pressures, the freestream dynamic pressure and the stagnation thermodynamic quantities are recorded. In this way, a calibration map that relates port pressures to velocity can be created. One map is created for each Mach/Reynolds number.

For more information about aerodynamic calibration facilities and instrumentation, please see the conventional Aeroprobe brochure. Typical calibration speed ranges for the Omniprobe are given in Table 4 as a function of omniprobe tip diameter. Note that calibrations at speeds in excess of 70 m/s require the 6.35mm tip option, because of restrictions on the cross-sectional area of flow in our high-speed calibration facility.

Re-Calibration Interval:

The Omniprobes are designed to maintain the aerodynamic calibration for long periods, as long as the probe tip is not damaged or scratched and the tip geometry of the probe is not altered. Under normal operation and storage, the recommended calibration interval is 18-24 months.

Table 5: Standard Calibration Speed Ranges for Typical Omniprobe Tip Diameters

Omniprobe Tip Diameter (mm)	Calibration Velocity Range
6.35	5 to 320 m/s
9.53	5 to 70 m/s

Omnipro Pressure-to-Velocity Reduction Software

The omniprobe pressure-to-velocity reduction software package is a post-processing, Windows-compatible package. A window from the program is shown in Figure 3.

The software utilizes a local-least squares (LLS) fit of the closest (to the test point in question) calibration points, for each of the calibration variables. The LLS searching algorithm uses specialized multi-region search routines to improve accuracy.

The reduction algorithm has typical average errors of 1% (or less) in the velocity magnitude and 0.5° (or less) in the flow angles, when used with calibration data generated in our facilities.

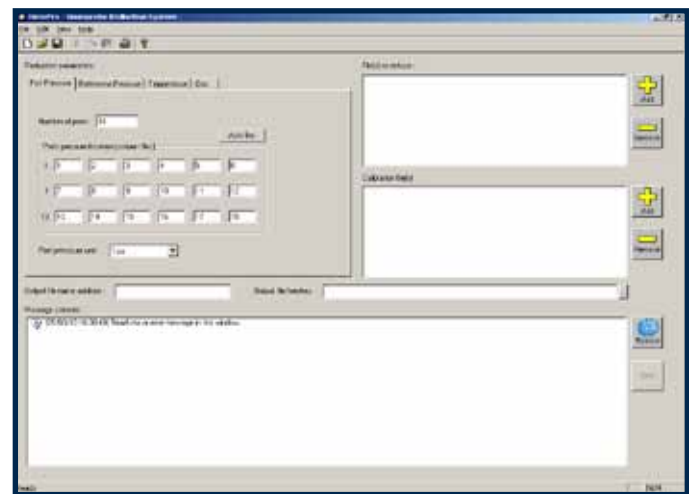

Figure 3: Omniprobe Pressure-to-Velocity Reduction Software Screen Capture

Ordering Information

Item	Description
	Standard Omniprobes
PS12	Standard Straight 12-hole Omniprobe, Calibrated
PL12	Standard L-Shaped 12-hole Omniprobe, Calibrated
PS12-HT900	Straight High-Temperature Omniprobe, 9.53 mm Tip OD, Rated to 900°C
	Standard Omniprobe Tip Options
TIP-OMNI6	6.35 mm Tip Diameter
	Omniprobe Calibrations
SPCO	Standard Setup and Calibration of Omniprobe (Specify Speed)
XC0	Extra Omniprobe Calibration (Specify Speed)
	Custom Omniprobes
CPS12	Custom Straight 12-hole Omniprobe, Calibrated
CPL12	Custom L-Shaped 12-hole Omniprobe, Calibrated
	Tubing
ETUB-3-1	Flexible Tubing for Probe Pneumatics, 1/32" ID, 3/32" OD, 50 ft
	Repair
RPRP-OMNI-B	Probe Repair, Base
RPRP-OMNI-E	Probe Repair, Extended
	Pressure-to-Velocity Reduction Software
SW-OMNI	Omnipro Reduction Software

Additional Information

For information about other Aeroprobe products, please visit our website: www.aeroprobe.com.

Requirements

Use of omni-probes requires ability to measure port pressures. Aeroprobe provides complete pressure data acquisition systems and software for this purpose (sold separately). The Omnipro software requires Windows OS.

Notes:

- Standard Omniprobes Are Shown in Figure 1, All Other Geometries Must Be Given a Custom Designation.
- All Standard Probes Include One Standard Calibration at a Speed of the Customer's Choice (5 m/s - 320 m/s for 6.35 mm Tips, and 5 m/s - 60 m/s for 9.53 mm Tips). **Specify Speed on Order!**
- Custom Omniprobes Include One Standard Calibration at a Speed of the Customer's Choice if Omniprobe Geometry Permits



Figure 4: 9.53mm Omniprobe Tip

Conventional Omniprobe Specifications

Geometry and Construction		Measurement Accuracy (w/Aeroprobe Calibration)	
Probe Geometry	Straight, L-Shaped	Flow Angles	< 0.5°
Number of Holes	12 (18 Available for Legacy Applications)	Total Flow Velocity*	< 1.0%
Tip Geometry	Spherical	Required Auxiliary Data**	Reference Pressure, Total Temperature
Tip Diameter	9.53 mm; 6.35 mm Standard Option	Flow Angle of Receptivity	Cone Angle: <ul style="list-style-type: none"> • V < 70 m/s: 160° • V > 70 m/s: 150°
Material	Stainless Steel	Calibration Flow Speeds	5 m/s to 320 m/s (Mach = 0.95)
Pneumatic Connection	Tygon R3603 Formulation, 1/32" ID, 3/32" OD Standard for Exit Tubing of 0.89 mm – 1.6 mm (0.035" – 0.063") OD.	Pressure Data Reduction	Omnipro Software, Returns Flow Vector from Set of Port Pressures
		Frequency Response	Low, Best for Determining Time-Averaged Flows, Time Response/Bandwidth Available Upon Request
Mounting	Hex Prism (9.53 mm Flat-to-Flat Standard), Rectangular Prism, Cylindrical	Media	Non-Reactive Gases (Brass/Stainless). Other Media Possible – Contact Aeroprobe
Probe Angle Reference	Straight: Flat on Hex Mount Bent: Plane of Bent Probe Tip	Temperature Measurement	Tip Thermocouple Option, Compatible with AeroAcquire Data Acquisition Software
Flow Temp. Limits	0°C – 450°C		
*Utilizing 0.1% Accurate Pressure Sensors Properly Rated for Flow Speed		**For Most Accurate Compressible P-V Reduction	

