

P9000



- High accuracy through digital compensation
- High thermal stability
- Rugged stainless steel construction
- Ideal for test stands
- High burst pressure limit

DESCRIPTION

The P9000 Series is a range of advanced, digitally compensated pressure transducers. The unique design of the P9000 pressure transducer utilizes the proven reliability of strain gauge technology and innovative digital compensation electronics. The synergy of these technologies results in an instrument grade pressure transducer. Available in pressure ranges from 75 psi to 10,000 psi (5 bar to 700 bar), the P9000 series can be configured with a variety of pressure ports, electrical outputs, and termination options to meet most pressure sensing needs.

The P9000 Series incorporates 12 bit digital compensation electronics to ensure precise calibration of all critical parameters. This unique circuit design also provides a significant advantage of maintaining a true analog “through-path” resulting in an exceptionally fast response of 1000 Hz without a sacrifice in accuracy. Error contribution sources are digitally corrected to guarantee repeatable performance and eliminate the need for user calibration. Combined nonlinearity hysteresis and non-repeatability errors are guaranteed to be less than $\pm 0.08\%$ F.R.O. with total thermal error limited to 0.004% F.R.O/ $^{\circ}\text{C}$ over an extended industrial temperature range of -4°F to 176°F (-20°C to 80°C).

The P9000 series delivers the advantages of a 17-4 PH diaphragm offering a true stainless steel isolation barrier with high burst pressures, at 20x the rated pressure, and a proof pressure up to 5x the rated pressure. Housed in a rugged 316 stainless steel, NEMA 4X, IP67 enclosure with guaranteed shock resistance of up to 1000g for 2msec, and vibration to $\pm 20\text{g}$, the P9000 provides a robust solution for a wide variety of demanding pressure applications and environments.

Available in both cable and connector outlets, the P9000 is offered in various electronic outputs: four wire 0-10 V, four wire 0 to 5 V and a 2 wire 4-20 mA version. The P9000 can be configured to give 3-wire 1 to 6V or 1 to 11V output. All P9000 units are constructed under an ISO 9001 environment. Each unit is serialized and shipped with a calibration certificate guaranteeing the highest quality and reliability found in an instrument grade pressure transducer.

P9000

FEATURES

- Guaranteed Accuracy of better than $\pm 0.08\%$ F.R.O.
- Rugged Stainless Steel Construction
- Pressure Ranges: 0-75 psi to 10,000 psi (0-5 bar to 0-700 bar)
- 5x Overload Capacity
- IP67, NEMA 4x Rated
- Long Term Stability 0.1% F.R.O. per annum
- Thermal Performance: $< 0.002\%$ F.R.O./ $^{\circ}\text{F}$ ($< 0.004\%$ F.R.O./ $^{\circ}\text{C}$)
- CE Certified

APPLICATIONS

- Hydraulic and Pneumatic Controls
- Steel and Aluminum Rolling Mills
- Pulp and Paper Mills
- Automotive Test Stands
- Power Generation
- Off-Shore Oil Exploration

PERFORMANCE SPECS

Series	P9060	P9070	P9080
Model Number	P906X	P907X	P908X
Input Voltage	10 to 36VDC	15 to 36VDC	10 to 36VDC
Current (mA max)	<6	<6	N/A
Output (F.R.O)	5V \pm 0.3%	10V \pm 0.3%	4-20 mA (16 mA \pm 0.3%)
Impedance (ohms)	<1	<1	-
Load Resistance (ohms min.)	1000	2000	1300 max at 36V
Frequency Response	1 kHz	1kHz	1kHz
Combined Non-linearity, Hysteresis and Non-repeatability			
High Range % F.R.O. (BSL)	< ± 0.05 typ	< ± 0.05 typ	< ± 0.05 typ
	< $\pm 0.08\%$ max	< $\pm 0.08\%$ max	< $\pm 0.08\%$ max
Combined Thermal Zero & Sensitivity Error: (calculated from end points of temp. range) The output will not deviate from 20$^{\circ}\text{C}$ by more then 0.5% F.R.O., over a temperature range of -20 to +80$^{\circ}\text{C}$.			
% F.R.O./ $^{\circ}\text{F}$	< ± 0.002	< ± 0.002	< ± 0.002
% F.R.O./ $^{\circ}\text{C}$	< ± 0.004	< ± 0.004	< ± 0.004
Residual Unbalance % F.R.O.	0 Volts $\pm 0.3\%$	0 Volts $\pm 0.3\%$	0 Volts $\pm 0.3\%$
Weight oz (gm) max (0001 version)			
Connector Version	5.11 (145)	5.11 (145)	5.11 (145)
Cable Version	6.35 (180)	6.35 (180)	6.35 (180)

P9000 Series Pressure Transducer

COMMON SPECIFICATIONS

All specifications are at 20°C (unless otherwise noted). Measurement Specialties reserves the right to update and change these specifications without notice.

Pressure Ranges

High (psi)	0-75, 100, 150, 200, 250, 350, 500, 750, 1000, 1500, 2200, 3500, 5000, 7500, 10,000
(bar)	0-5, 7, 10, 15, 25, 35, 50, 70, 100, 150, 200, 250, 350, 500, 700
DIN (bar)	6, 10, 16, 25, 40, 60, 100, 160, 250, 400, 600

Pressure References

High Pressure Range	Vented gauge 1: 0-75 to 0-350 psi Absolute and sealed gauge: 0-75 to 0-10,000 psi
----------------------------	--

Pressure Limit 5x full range pressure or 12,000 psi (830 bar), whichever is less. Will not cause a zero offset exceeding 0.04% FRO (recoverable within a few hours)

Burst Pressure 20 x full range pressure or 22,000 psi (1,520 bar), whichever is less

Pressure Media Liquids or gases compatible with 17-4 PH and 17-7 PH stainless steel or Inconel 625

Combined Non-linearity, Hysteresis

and Non-repeatability High Range: $\pm 0.05\%$ F.R.O. (Best Straight Line) Typical, $\pm 0.08\%$ FRO (Best Straight Line) Maximum

Temperature Range

Operable -40°F to 212°F (-40°C to 100°C)

Compensated -4°F to 176°F (-20°C to 80°C)

Storage -40°F to 257°F (-40°C to 125°C)

Humidity

Connector Version 95% Relative humidity

Cable Version Immersible to IP67 (fluid must not enter the ends of the cable)

Acceleration Response Above 500 psi (35 bar) $\pm 0.02\%$ F.R.O./g; below 500 psi (35 bar) $\pm 0.10\%$ F.R.O./g

Vibration Surpasses MIL STD810C Method 514-2 Curve L

Shock 1000 g for 2 msec will not damage the sensor

EMC The P940, P950, P960 and P980 and P990 Series are CE marked, and when correctly installed comply with the EMC Directive 89/336/EEC Generic Standards for Residential Commercial, Light Industrial and Industrial environments. Note: The P980 Series when used in Intrinsic Safety applications does not comply with the Industrial environment directive.

Insulation Resistance 500 MOhm at 50 VDC at 25°C

¹ Vented gauge units must only be used in dry, non-corrosive environments and will breathe through the cable vent tube or hole in the 6-way receptacle.

P9000 Series Pressure Transducer

DIMENSIONS

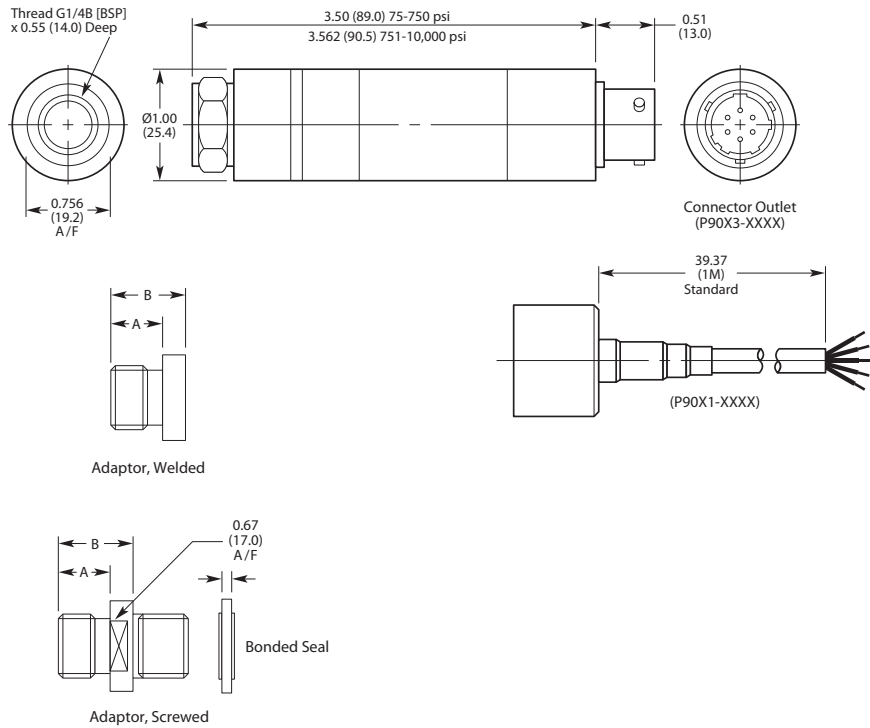

ADAPTERS

Thread Size	Code	Dimensions in (mm)	
		Welded A	B
G1/4A (BSP) (F)	0002	0.46 (11.7)	0.67 (16.9)
M14 x 1.5 (M)	0003	0.40 (10.2)	0.61 (15.4)
7/16" -20UNF-2A (M)	0004	0.56 (14.3)	0.77 (19.5)
1/4" -18NPT (M)	0005	0.55 (14.0)	0.76 (19.2)
M10 x 1.0 (F)	0006	-	0.60 (15.2)
	1/4" -18NPT (F)	0009	

Thread Size		Screwed A	B
G1/4A (BSP) (F)	0022	0.46 (11.7)	0.70 (17.8)
M14 x 1.5 (M)	0023	0.40 (10.2)	0.62 (15.8)
7/16" -20UNF-2A (M)	0024	0.56 (14.3)	0.78 (19.8)
1/4" -18NPT (M)	0025	0.55 (14.0)	0.80 (20.4)
M10 x 1.0 (F)	0026	-	0.60 (15.2)

P9000 Series Pressure Transducer

CONNECTIONS

Cable	Connector**	
Red*	Pin A*	Excitation (+)
White	Pin D	Excitation (-)
Yellow	Pin B	Output (+)
Blue*	Pin C*	Output (-)
Violet	Pin E	No Connection
Grey	Pin F	Factory use only

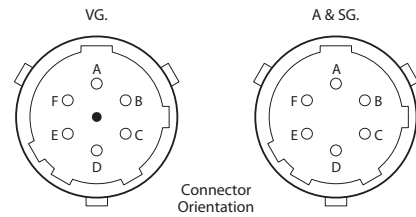

Note: Screen is connected to the case for CE marked units.

* 2-wire connections

**Vented gauge units must breathe through the receptacle (mating connector must have a vent hole)

Mating socket is supplied with connector version.

WIRING

P906X and P907X

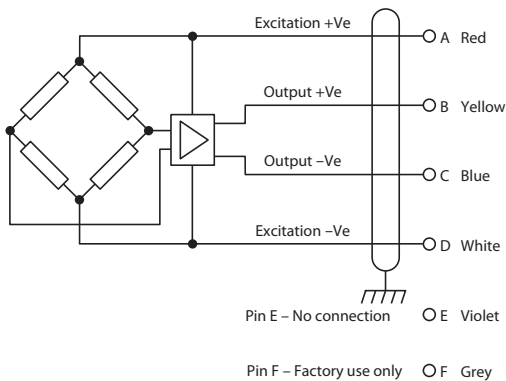

P908X

