

Model SPC4000 Pressure Calibrator

- 0.01% F.S. accuracy
- Up to 4 calibration ranges, 0.36 to 850psig
- Based on Mensor CPC6000 automated pressure calibrator
- Removable/interchangeable transducers
- Color touch screen
- Automated DSA & ZOC calibrations
- Bench or rack mount



SPC4000 System

■ System Overview

The model SPC4000 pressure calibrator is designed to provide automated calibration of Scanivalve Corp's DSA and ZOC series pressure scanners. The calibration system consists of 3 components.

1. The heart of the calibration system is the Scanivalve pressure calibrator, model SPC4000. The SPC4000 calibrator has up to two independent precision pressure regulators. Each regulator can have up to two gauge transducers; thus up to 4 transducers per calibrator. Transducers can be quickly removed or calibration or service.
The transducers are Gauge (psig). Full Scale pressure ranges are available between 0.36 psig and 850 psig.
2. Scanivalve's Pneumatic Logic Unit (SPCPLU) is required for automated DSA & ZOC calibrations. This unit contains the pneumatic solenoid valves and manifolds required to perform single or multi- range calibrations, as well as zero offset corrections.
3. A utility program, PressCal is included with the SPC4000. It performs automated or manual calibrations on all DSA and ZOC pressure scanners by controlling the pressure calibrator and SPCPLU. The PressCal program is hosted in a Windows XP® environment. PressCal updates the module calibration coefficient files and generates "as received" and calibration validation reports.

■ Applications

This SPC4000 pressure calibrator is based on the Mensor Corp. model CPC6000 pressure calibrator with specific changes made to work with Scanivalve products. These changes include additional digital outputs to control the SPCPLU as well as modified OEM firmware to accept Scanivalve commands.

In order to perform multipoint calibrations and zero offset corrections on demand to DSA & ZOC pressure scanners, the calibrator must be used with the SPCPLU. The reference side of the gauge transducers can be connected to an alternate remote location (tunnel static, elevated line pressure, static basket, etc).

The calibration system can be used for many applications including multi-point calibration of DSA and ZOC pressure scanners, zero offset correction, and leak testing.

The calibrator can also be used in the local/manual mode utilizing the front panel touch screen or remotely via Ethernet. It would be used in this standalone mode to regulate and measure pressures to calibrate individual pressure transducers. It could be used to send known pressures to all of the DSA/ZOC sensors to insure they are reading correctly (System Validation).

Windows XP® is a registered trademark of Microsoft Corp.

■ Modular Calibrator Design

1. The SPC4000 brings a high degree of flexibility by having a variety of configurations available. It can have one or two independent pressure regulators providing two pressure outputs.

Each regulator can have up to two transducers.

Each transducer module contains all of the calibration, characterization, communication functions and information needed to communicate the pressure reading to the system electrical module.

2. Transducer modules can be easily removed or replaced. Compatible spare transducers of the same or different range can be interchanged to increase utilization.



Calibrator Chassis



Regulators



Transducers

■ The Regulator

The SPC4000 has four unique pressure regulators available depending on transducer ranges selected. The Pump Regulator utilizes a pump to both generate and regulate pressure. It can generate pressures as low as 0.5 psia and is generally used when extreme precision is needed at very low gauge pressures or when an external pressure source is not available.

The other 3 regulators are determined by the range of calibrator transducers selected. The appropriate regulators will be matched for the specific transducer pressure ranges. These regulators require an external pressure source that is approximately 10% above the full scale range of the highest internal pressure range.

Gauge (psig)

Available Regulators	Min	Max
Pump-Very Low Pressure	0-0.36	0-15
Low Pressure	0-1	0-50
Medium Pressure	0-10	0-150
High Pressure	0-75	0-850

All regulators can be tuned in the field to meet a specific customer external volume requirement. Specific control requirements, such as control speed, overshoot, and external volume, are just a few of the variables the regulator is able to accommodate.

■ Calibrator Transducer

The transducers are configured in a proprietary process characterizing each pressure range over temperatures from 15 to 45° C. This process has been optimized to provide the greatest accuracy, stability, and reliability. Each range is calibrated with NIST traceable primary standards and provided with a calibration certificate.

Transducers 15 psi and above have an uncertainty of +/- .01% F.S. with a one year calibration interval.

Transducers 14.9 psi and below have an uncertainty of +/- .01% F.S. with a 6 month calibration interval.

Standard Transducer Ranges

Gauge Transducer	Gauge Transducer
0.36 psig	100 psig
1 psig	200 psig
5 psig	300 psig
15 psig	500 psig
30 psig	750 psig
50 psig	850 psig

■ Standalone/Manual Calibration

Manual calibrations can be performed with the SPC4000 by using either the color touch screen or remote commands via Ethernet. This manual mode using remote commands can be used with Scanivalve's DSA or ZOC pressure scanners. When calibrating individual pressure transducers, the touch screen or remote commands may be used.



The color touch screen provides an intuitive user interface that can be configured in 17 different languages.

■ SPCPLU Automated Calibration

Features

- Contains leak tight pneumatic valves
- Works with 1 to 4 pressure ranges
- Works in conjunction with Scanivalve's SPC4000 pressure calibrator
- Facilitates automated and manual DSA & ZOC calibrations

General Description

The calibrator system consists of 3 components:

1. SPC4000 calibrator,
2. The Pneumatic Logic Unit (SPCPLU) is a box that contains pneumatic solenoid valves and manifolds required to perform single or multi-range DSA & ZOC calibrations, as well as zero offset corrections. It also switches the DSA or ZOC calibration valve into sense, calibrate, purge, and leak test modes.
3. Scanivalve's PressCal software program orchestrates the pressure calibrator and SPCPLU to perform automated and manual calibrations.

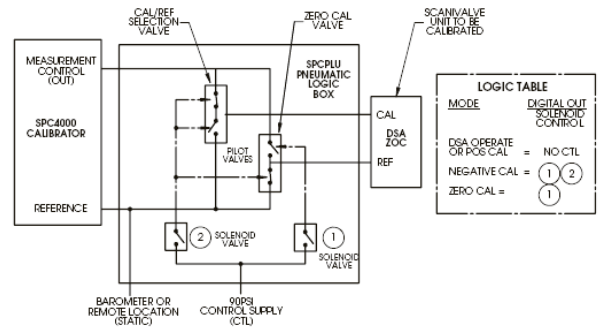

■ Applications

The SPCPLU is controlled by the SPC4000 pressure calibrator. The unit incorporates piloted high flow pneumatic valves that support:

- Multi-point calibrations of DSA and ZOC pressure scanners for up to 4 pressure ranges
- Positive or below atmospheric (vacuum) calibrations
- Zero offset correction on demand
- Leak testing of system, DSA, or ZOC pressure scanners



SPCPLU shown

Solenoid valves direct the pressure for the piloted valves when digital output commands are issued. The SPCPLU is designed to work in conjunction with the SPC4000 calibrator to auto calibrate DSA and ZOC pressure scanners.

Models: SPCPLU-1 supports 1-2 press. ranges
SPCPLU-2 supports 1-4 press. ranges

Power

Requirements: SPCPLU receives power from SPC4000

Weight: SPCPLU-1 6.9 lbs. (3.13kg)
SPCPLU-2 11.5 lbs. (5.22kg)

Communication:

SPC4000 Ethernet TCP/IP
SPCPLU Controlled by SPC4000 digital outputs

Pneumatic

Connectors: 1/4 inch Swagelok® fittings

Solenoid Supply

Pressure: 90-120 psi (user supplied)

Pressure range: 850 psi maximum

Dimensions: 19" wide X 3.5" tall X 13" deep
(48.3cm wide X 8.9cm tall X 33cm deep)

■ SPC4000 Calibrator Specifications

Measurement Units:

psi, inHg, inH₂O, ftH₂O, ATM, bar, mbar, mmH₂O, cmH₂O, cmHg, Torr, kPa, Pa, Mpa, PSF, C. Other units and 2 user-defined units are also available.

Resolution:

4 to 7 significant digits, user selectable

SPC4000 General Specifications

Communications: Ethernet

Warm-up:

Approximately 30 minutes to achieve full accuracy depending on the environment

Local User interface-Display:

8.4" color LCD display with an 8 wire resistive touch screen

Case Dimensions:

14.02" wide x 7.55" high x 12.42" deep (35.61 cm x 19.2 cm x 31.55 cm)

Weight: 36 lbs. (16.33 kg) with all internal options

Pressure Media:

Clean, dry, non-corrosive, non-combustible, non-oxidizing gases—not suitable for oxygen use

Operating Temperature Range:

0°C to 50°C. Note: The compensated temperature range is 15°C to 45°C

Pneumatic Interface: 1/4 inch Swagelok® fittings

Power Requirement:

100-240 VAC, 47-63 Hz, 75 VA

Compliance:

The SPC4000 (Mensor CPC 6000S) complies with EN61326-1:A1:1998, EN61326-1:A2:2001, EN55024:1998, and EN61010-1-1

Calibration Interval

Recommended SPC4000 calibration intervals are: 14.9 psi and below every 6 months - 15 psi and above once per year.

The calibrator has firmware for field calibration. A dead weight tester is required for field calibration or the SPC4000 may be returned to Scanivalve's factory for calibration.

■ Ordering Information

Scanivalve's technical sales staff is available to guide you in the selection of an appropriate regulator and transducers to meet your test calibration requirements. This process involves optimizing the mix of ranges to allow calibration of all of your DSA or ZOC pressure scanners.

Choose the calibrator transducer ranges needed to calibrate your transducers or pressure scanners. Standard ranges (gauge) are shown in the table below.

0.36 psig	1 psig	5 psig	15 psig	50 psig
100 psig	200 psig	300 psig	750 psig	850 psig

Complete Ordering Description (example)

Scanivalve model **SPC4000/ 50, 100, 300, 500 psig plus note if you want optional internal barometer.**

SPC4000 Options

1. Additional/Spare Transducers

Additional transducers can be purchased. Although transducers will work in any regulator, the range of the regulator must be considered to insure optimum performance.

2. Barometric Reference Transducer

The barometric reference transducer is an absolute pressure device used to accurately measure local atmospheric pressure. The barometric reference has an uncertainty of 0.01% of full scale with a recommended calibration interval of 6 months. It can be specified with any SPC4000 configuration.



3. Pneumatic Distribution Panel

This product incorporates up to 5 pressure regulators for applying and setting pressures manually on large pressure measurement systems. It manages the pressures that are fed into the SPC4000. Unit is rack mounted.

We reserve the right to change these specifications without notice