

Compression Load Cell ACDUP Series

- Capacity 0...15 t and 0...25 t
- Specially designed for Truck Scales
- High overload tolerance
- Self centering design
- Accuracy 0,02 %
- Center loaded double ended shear beam design
- Protection against harsh environment

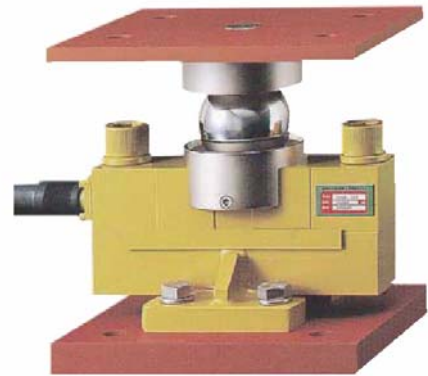

The model ACDUP is specially designed for truck and railroad scales in harsh environments. The effective integration of the ACDUP mount and double ended shear beam load cell eliminates the need for troublesome check roads, links, expansion assemblies and other peripheral hardware. The unique spherical ball point loading mechanism makes lateral movement of the assembly possible, while controlled floating of the scale deck is allowed. High alloy tool steel load cell offers superior corrosion protection with waterproof potting.

Ordering Information: **ACDUP** - **15T**
 Model - Capacity

Specifications

Model	ACDUP
Rated capacity R.C.):	15 t (147,1 kN) 25 t (245,2 kN)
Rated output (R.O.):	2 mV/V \pm 0,15%
Non-linearity:	\leq 0,02% R.O.
Hysteresis:	\leq 0,02% R.O.
Non-repeatability:	\leq 0,02% R.O.
Creep error:	\leq 0,03% in 20 min.
Zero balance:	\leq 1% R.O.
Compensated temp. range:	-10...70°C
Operating temperature range:	-20...80°C
Temp. effect on rated output:	\leq 0,02% load/10 K
Temp. effect on zero balance:	\leq 0,03% R.O./10 K
Terminal input resistance:	800 Ω \pm 30 Ω
Terminal output resistance:	700 Ω \pm 5 Ω
Insulation resistance (min):	2000 M Ω at 50 VDC
Excitation voltage:	10 V (rec.) / 15 V (max.)
Electrical connection:	\varnothing 7mm x 10m (22AWG x 4 core shielded)
Protection class:	meets IP67
Safe overload:	150% R.C.
Ultimate overload:	300% R.C.
Weight:	33 kg

Wiring Information:

red: + Excitation	green: + Signal
white: - Excitation	blue: - Signal
bare: GND	

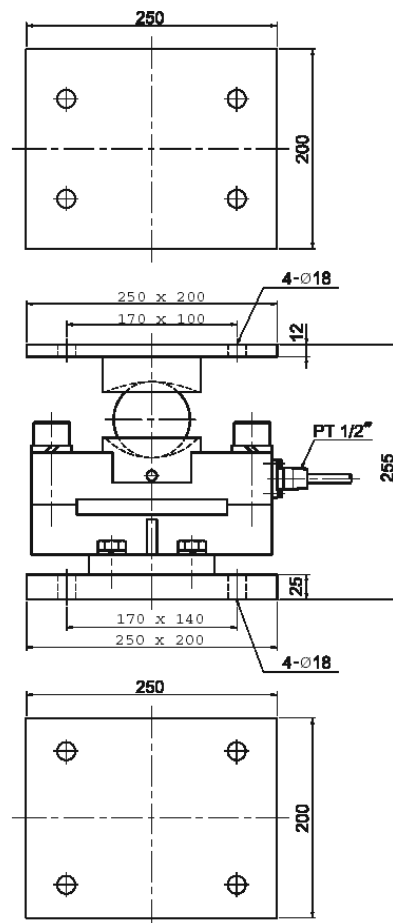

*Specifications are subject to change without any notice/Copyright Althen 03-2006

ALTHEN GmbH Mess- und Sensortechnik

Frankfurter Str. 150 - 152
 D-65779 Kelkheim

Tel. : +49 (0)6195 70060
 Fax: +49 (0)6195 700666

<http://www.althen.de>
 E-Mail: verkauf@althen.de

