

ALF310

Axial Force and Torque Transducer

- Measurement range ± 50 N and 2 Nm
- Tension / compression
- Non-linearity ± 0.05 % RL
- Output signal 0.6 mV/V or rationalised 0.5 mV/V ± 0.5 %
- Supply voltage 10 VDC



The ALF310 depicted measures force and torque in the same axis with minimal cross talk providing user friendly outputs for direct measurement without mathematical manipulation.

Each channel may be calibrated bi-directionally. The version of the transducer depicted was developed for an OEM producing texture analyser machines (rheometers) for use in the food process industry.

Geometry:

Monocoque strain structure with no moving parts.

■ Dimensions

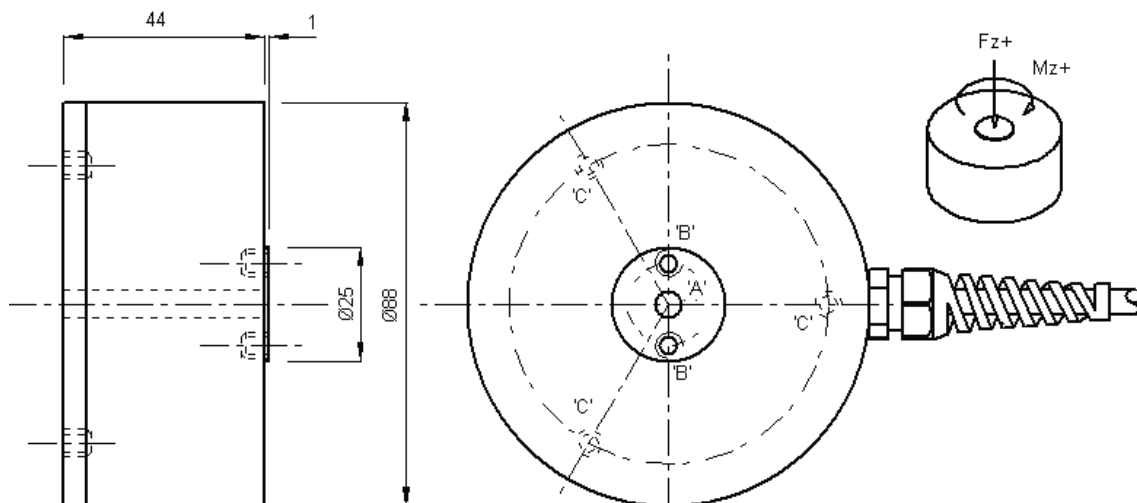

'A'	$\varnothing 6$ mm through hole
'B'	2 tapped holes M6 x 1 on a 18 mm PCD
'C'	3 tapped holes M6 x 1 equi-spaced (120°) on a 70 mm PCD

Dimensions in „mm“, approx. values

These drawings are for information only and not intended for construction purpose.
Please contact us for detailed drawings.

■ Specification

Rated load:	±50 N
Rated torque:	2 Nm
Non-linearity, terminal:	±0.05 % RL
Hysteresis:	±0.05 % RL
Creep, 5 min:	±0.1 % AL
Repeatability:	±0.05 % RL
Maximum cross talk:	1 % RL
Rated output, nominal:	0.6 mV/V
Rated output, rationalised:	0.5 mV/V ±0.5 % RL
Zero load output:	±4 % RL
Temperature effect on rated output:	±0.005 % AL/K
Temperature effect on zero load output:	±0.02 % RL/K
Compensated temperature range:	-10 ... +50 °C
Operating temperature range:	-10 ... +80 °C
Supply voltage, recommended:	10 V
Supply voltage, max.:	10 V
Bridge resistance:	350 Ω
Insulation resistance, minimum at 50 VDC:	500 MΩ
Overload, safe:	150 % RL
Overload, ultimate:	400 % RL
Dynamic load capacity:	70 % RL
Weight (excl. cable):	approx. 250 g
Material:	Aluminium

Notes:

1. RL = rated load
2. AL = applied load
3. Temperature coefficients apply over the compensated range.
4. Values apply to force and moment in all load combinations.
5. Extraneous forces or torques other than those calibrated may create moment errors.

■ Electrical Connections

The ALF310 is fitted with 2 m of PVC insulated 9 core screened cable type 7-1-9C. The screen is not connected to the load cell body.

Wiring:

Function	Colour	
	Fz	Mz
+ supply voltage	red	violet
- supply voltage	blue	black
+ output signal	yellow	brown
- output signal	green	white
screen	orange	

■ Ordering Codes

ALF310-Zxxxx special order number

Please add range in the required units.

Due to continual product development, ALTHEN and partners reserve the right to vary the foregoing details without prior notice.