

## GC-485

### Schaevitz™ Ultra Precision Digital I/O Gage Head

- Measurement ranges from  $\pm 1.27$  mm to  $\pm 25.4$  mm
- LVDT gage head
- Linearity max. 0.1 % of FS
- Output RS485
- Supply voltage 8.5 ... 30 VDC



The GC-485 Series of heavy-duty, spring loaded gage heads are self-contained, ultra precision, digital I/O devices for high performance measurements in environments containing moisture, dirt, and fluid contaminants. The GC-485 eliminates the need for expensive and error-prone analog to digital conversion by internally converting the analog LVDT signals into engineering units (imperial or metric). The result is a fully calibrated and traceable measurement device, ready for installation, and 100% field interchangeable.

Operating on 8.5 to 30 VDC supply, the GC-485 provides an addressable RS-485 loop output (MODBus RTU and ASCII protocols) running at 119 kBd baud rate and capable of handling up to 32 devices communicating over two wires. MIN, MAX and TIR readings are sampled and stored internally at a maximum update rate of 600 samples per second, and are provided to the host on demand. A velocity output (inch or mm per second) is also available, while an internal tare (zero) function affords maximum measurement range flexibility.

These robust gage heads feature a removable black-chromed, hardened tool steel tip threaded (4-48UNF-2A) to the working end. Internal construction prevents the core and shaft from rotating as they move longitudinally. The welded electrical connector allows replacement of a damaged cable without sacrificing the sensor. The external  $\frac{1}{2}$ -20 threads and the two supplied locknuts facilitate installation and adjustment.

The ruggedness, long life cycle, and very high reliability of the GC-485 provide the lowest cost of ownership over the life of the equipment onto which they are installed. The one-piece front end (barrel), machined from solid stainless steel bar, coupled with a bronze bushing, has far greater resistance to side loads compared to other designs; it reduces the risk of probe damage during installation or maintenance. The GC-485 design also require fewer parts and weld joints, thereby increasing overall structural integrity and reliability.

#### ■ Features

- All-welded stainless steel construction
- MS type connector (MIL-C-5015)
- Hardened tool steel contact tip
- High side load resistance
- Programmable filtering
- Calibration certificate supplied with each unit
- Air extend/spring retract available

#### ■ Applications

- Roller Gap Control
- In-process Wet Grinding
- High Density Gaging
- Hand Held Gages
- X-Y Positional Feedback
- Remote Monitoring
- Applications where wiring must be minimized

#### ■ Specifications

Stroke range:	$\pm 0.05$ inch ( $\pm 1.27$ mm), $\pm 0.125$ inch ( $\pm 3.17$ mm), $\pm 0.25$ inch ( $\pm 6.35$ mm), $\pm 0.5$ inch ( $\pm 12.7$ mm), $\pm 1.0$ inch ( $\pm 25.4$ mm)
Input voltage:	8.5 ... 30 VDC
Input current:	50 mA
Output:	RS-485 (ModBus RTU and ASCII protocols)
Baud rate:	119 kBd
Resolution, min.:	15 bit
Linearity, max.:	$\pm 0.1$ % of FS, (typ. $\pm 0.05$ % of FS)
Repeatability:	0.6 $\mu$ m (25 $\mu$ inch)

Stability:	0.1 % of FS
Temperature coefficient of scale factor, max.:	0.045 %/K
Frequency response (dyn.), max.:	15 Hz
Operating temperature:	-25 ... +85 °C
Storage temperature:	-55 ... +95 °C
Shock survival:	250 g (11 ms half-sine)
Vibration tolerance:	10 g up to 2 kHz
Housing material:	AISI 400 Series stainless steel
Electrical connection:	6-pin MS style hermetic connector
Environmental protection:	IP68 to 68 bar with use of proper mating connector plug, NEMA IEC 60529

**Notes:**

- All values are nominal unless otherwise noted
- FS: Full Scale is 2X for ±X stroke

**Mechanical Specifications**

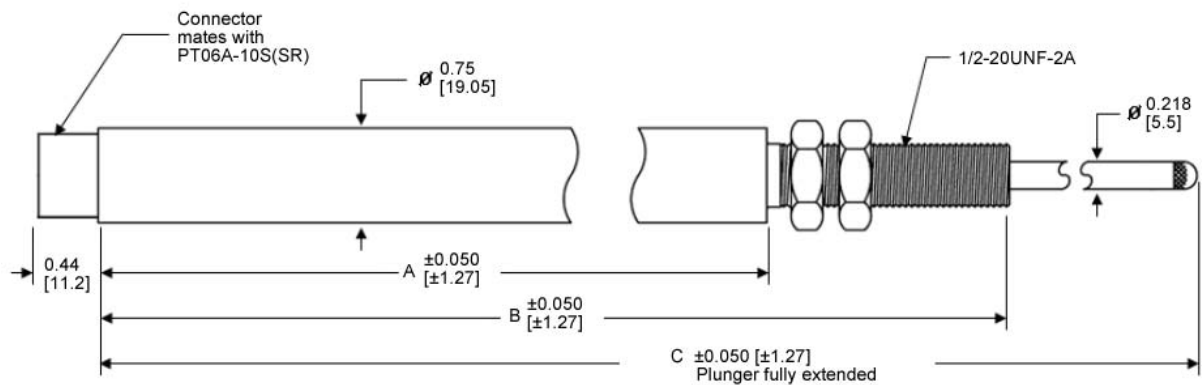

All dimensions in inches, values in brackets in mm, approx. values.

These drawings are for information only and not intended for construction purpose. Please ask for detailed drawings.

Model	Stroke range		Pre-travel		Over-travel		Dimensions, approx.					
							A		B		C	
	inch	mm	inch	mm	inch	mm	inch	mm	inch	mm		
<b>GC-485-050</b>	±0.050	±1.27	0.25	6.35	0.31	7.87	4.06	103.1	5.42	137.7	6.48	164.6
<b>GC-485-125</b>	±0.125	±3.17	0.28	7.1	0.29	7.4	4.90	124.5	6.27	159.3	7.30	185.4
<b>GC-485-250</b>	±0.25	±6.35	0.18	4.6	0.03	0.8	5.76	146.3	7.13	181.1	8.16	207.3
<b>GC-485-500</b>	±0.5	±12.7	0.20	5.1	0.35	8.9	7.46	189.5	10.45	265.4	12.93	328.4
<b>GC-485-1000</b>	±1.0	±25.4	0.10	2.5	0.10	2.5	9.42	239.3	12.41	315.2	14.87	377.7

**Wiring Information**

Power in	E
Common	D
A (- Data)	A
B (+ Data)	B

**Optional Contact Tips**

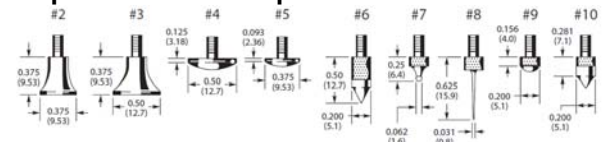

All dimensions in inches, values in brackets in mm, approx. values.

Due to continual product development, ALTHEN and partners reserve the right to vary the foregoing details without prior notice.