

LCIT Series

The **LCIT Series** is based on a patented linear position sensor design that features all of the benefits of current LVDT inductive technology, but at a significantly lower cost. The proprietary coil and electronics design of the LCIT has allowed ALTHEN to dramatically increase the frequency response without increasing noise, and lower the mass of the core. Making the sensor ideal for dynamic applications, but is also within the price range of a standard potentiometer.

Like an LVDT, the new sensors are also noncontacting, and have no moving parts, thus, reducing the wear while offering excellent resolution and repeatability characteristics. Available with strokes from 0.25 in. to 4.0 in. and featuring linearity of 0.25%, the LCIT can be offered in a wide range of custom configurations, including a design that allows the moving part itself to be the spoiler. The Benefits of LVDT Technology, Without the Cost In the new LVDT line, the conventional ferromagnetic core on an LVDT has been replaced with a low-cost conductive spoiler and cost effective coil design that requires only a few turns of material.

FEATURES

- Linearity 0.25% of FS or better
- Integrated Signal Conditioning
- Rugged Stainless Steel Construction

APPLICATIONS

- General
- Instrumentation
- Tool Position
- Valve Position



dimensions

in (mm)

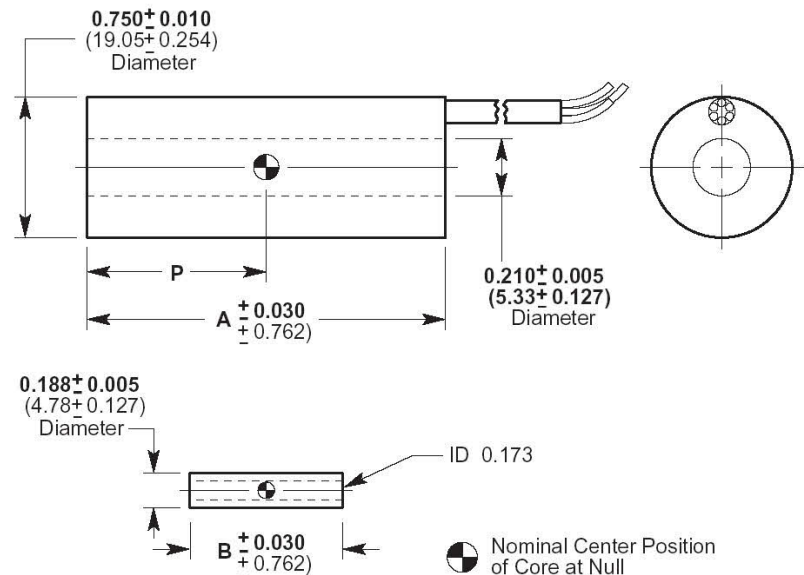

wiring

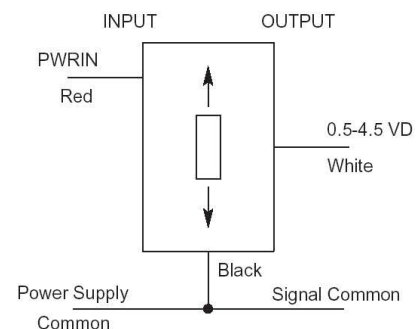

Specifications

Input Voltage	7-36 VDC, 20 mA (max)
Operating Temperature Range	32°F to 185°F (-0°C to 85°C)
Survival Temperature Range	-67°F to 200°F (-55°C to 95°C)
Output Voltage	0.5 to 4.5 VDC
Ripple	Less than 10 mV RMS
Linearity	0.25% full range
Frequency Response	-3 db@1KHz
Stability	0.125% full scale
Temperature Coefficient of Scale Factor	+/- 500 PPM/Deg. C
Shock Survival	250 g for 11 Milliseconds
Vibration Tolerance	10g up to 2 kHz
Coil Form Material	High Density, Glass-Filled Polymer
Housing Material	AISI 400 Series Stainless Steel
Lead Wire	4 Conductor, 28 AWG, Stranded Copper, 12" Long
EMC	TBA
Output Impedance	Less than 1 ohm

Electrical

Performance and Electrical Specifications

LCIT Series Model Number	Nominal Linear Range		Scale Factor		Response (-3 dB)
	Inches	Mm	V/inch	V/mm	kHz
250 LCIT	±0.125	±3.0	16	1.629	1
500 LCIT	±0.250	±6.0	8	0.315	1
1000 LCIT	±0.500	±12.5	4	0.157	1
2000 LCIT	±1.000	±25	2	0.018	1
4000 LCIT	±2.000	±50	1	0.039	1

Mechanical

Mechanical Specifications

LCIT Series Model Number	Weight Body gm	Core gm	Dimensions					
			A		B		P	
			In	Mm	In	Mm	In	Mm
250 LCIT	40	<1	2.60	66.04	0.850	21.59	1.30	33.02
500 LCIT	40	<1.5	2.60	66.004	1.300	33.02	1.30	33.02
1000 LCIT	50	<2	3.54	89.92	1.500	38.10	1.77	44.96
2000 LCIT	70	<2	5.54	140.72	2.700	68.58	2.77	70.36
4000 LCIT	TBD	TBD	10.37	263.40	5.000	127	5.19	131.83

We reserve the right to vary the foregoing details without prior notice.



ALTHEN GmbH Mess- und Sensortechnik

Frankfurter Strasse 150-152
65779 Kelkheim / Germany

phone: +49 (0)6195 70060
fax: + 49 (0)6195 700666

sales@althensensors.com
www.althensensors.com