



ISU-S | ISU-H

Inclinometer Boards

▣ Ranges 360° (4-x 90°)

▣ Accuracy:

ISU-S $\pm 0.1^\circ$ (at 0° and $90^\circ \pm 10^\circ$), other angles $\pm 0.2^\circ$

ISU-H $\pm 0.05^\circ$ (at 0° and $90^\circ \pm 10^\circ$), other angles $\pm 0.2^\circ$

▣ Supply voltage 5 VDC

▣ Output RS-232, PWM



The ISU series of Single-Axis Digital Inclinometers are self-contained, ready-to-use circuit modules which provide real-time digital measurements of angular displacement through a full 360 degree range. The ruggedized, non-contact capacitive sensor is combined with precision measurement circuitry to provide a cost-effective combination of accuracy, range, and operating temperature in an easy to use footprint. The units can be used in a wide variety of applications, accept a standard 5 Volt DC supply, and provide both RS-232 and Pulse Width Modulated (PWM) outputs.

Programmable options include power auto-shutoff and 4-bit addressability allowing up to six ISUs to be 'party-lined' together for applications requiring multiple sensors.

▣ Specifications ⁽¹⁾

Parameter		ISU-S Standard Accuracy	ISU-H High Accuracy
Range:		360°	
Accuracy:	0° $\pm 10^\circ$	$\pm 0.1^\circ$	$\pm 0.05^\circ$
	90° $\pm 10^\circ$	$\pm 0.1^\circ$	$\pm 0.05^\circ$
	Other angles	$\pm 0.2^\circ$	$\pm 0.2^\circ$
Resolution:	RS-232 output	0.00549° binary, 0.01° ASCII	
	PWM output	0.09°	
Temperature coefficient:	at 0° or 90° $\pm 1^\circ$	0.006°/K	
	Other angles	0.012°/K	
Repeatability:		$\pm 0.1^\circ$	$\pm 0.05^\circ$
Hysteresis ⁽²⁾:		0.10°	0.10°
Noise:		$\pm 0.2^\circ$	$\pm 0.01^\circ$
Time constant:		0.4 s typical	
Frequency response (-3dB):		0.4 Hz typical	
Angle output rate:		every 8/15 second (533 ms)	
Power input:	Voltage	5.0 VDC	
	Operating current	2 mA	
	Sleeping current	10 μ A	
Serial port:	Protocol	RE-232 (except for voltage levels)	
	Voltage	5 V	
	Baud rate	9600 Baud	
	Output impedance	10 k Ω	
PWM output:	Voltage	5 V	
	Frequency	30 Hz free running	
	Puls width	Varies 49.5 μ s per degree of angular displacement	

(1) Specifications subject to change without notice. Specifications are at 77 °F (25 °C) unless otherwise stated.

(2) Average over 360 degrees

Weight:		approx.. 23 g
Temperature range:	Operating	-30 ... +55 °C
	Storage	-55 ... +65 °C
Humidity sensitivity:		Conformal coated

▣ Dimensions and Wiring

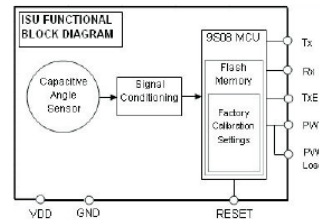
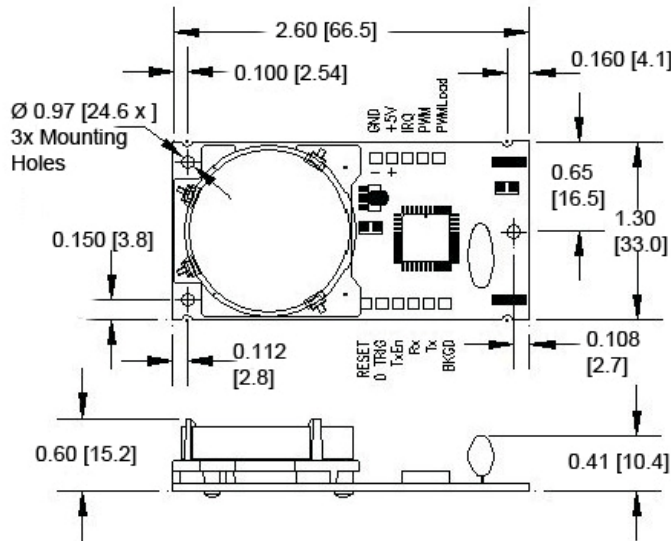

All dimensions in "inches", values in brackets in "mm", approx. values. These drawings are for information only and not intended for construction purpose. Please ask for detailed drawings. !

Notes:

- BKGD (Background) pin is for internal programming only. Customer use of this pin may damage the ISU.
- Customer may utilize either the existing PWM output directly driven by the MCU, or new optional PWMLoad, which is the same source but with SMBT3906 transistor driven output.
- Legacy half moon shaped indents remain for customer's existing mounting technique.
- Three new mounting through holes offered as optional mounting method.

Wiring	Pin	Existing HC05	New 9S08
Top Row	1 (closest to sensor)	5 V ground	5 V ground
	2	+5 V	+5 V
	3		
	4	PWM	PWM
	5	Not available	PWMLoad*
Bottom Row	1 (closest to sensor)	RESET	RESET
	2	0 Trigger	0 Trigger
	3	TxEN	TxEN
	4	Rx	Rx
	5	Tx	Tx
	6	Not available	Not for customer use.

* Same as PWM except the PWM signal is fed through a SMBT3906 PNP transistor. Not for use if using PWM. Customer can only use one at a time, either PWM or PWMLoad

▣ Ordering Information

Model	Order Part Number	Description
ISU-S	90104001	Standard accuracy version
ISU-H	90104020	High accuracy version

Due to continual product development, ALTHEN and partners reserve the right to vary the foregoing details without prior notice.