

Model 993A-5

General purpose, triaxial accelerometer with integral cable



- Features
- Rugged
 - General purpose
 - Industrial
 - Easy to mount

Dynamic

Sensitivity, ±10%, 25°C.....	100 mV/g
Acceleration range	50 g peak
Amplitude nonlinearity.....	1%
Frequency response:	
all channels, ±10%	2 - 2,000 Hz
Transverse sensitivity, max.....	5% of axial
Temperature response.....	
-50°C	+10%
+25°C	+0%
+80°C	+3%
-120°C	-7%

Electrical

Power requirement: voltage source.....	18 - 30 VDC
current regulating diode	2 - 10 mA
Electrical noise, equiv. g:	
Broadband 2.5 Hz to 25 kHz.....	150 µg
Spectral 10 Hz.....	20 µg/√Hz
100 Hz.....	2 µg/√Hz
1000 Hz.....	0.6 µg/√Hz
Output impedance, max.	100 Ω
Bias output voltage.....	12 VDC
Grounding.....	case isolated, internally shielded

Environmental

Temperature range	-50 to 120°C
Vibration limit.....	500 g peak
Shock limit	5,000 g peak
Electromagnetic sensitivity, equiv. g	250 µg/gauss
Sealing	Epoxy
Base strain sensitivity	0.002 g/µstrain

Physical

Sensing element design	PZT ceramic / shear
Weight	90 grams
Case material	Hardcoated Aluminum
Mounting	10-32 captive screw
Mating connector	Not applicable
Recommended cabling	Integral cable provided, J98, 6 ft.

Function	Cable conductor color
Axis X, power / signal	green
Axis Y, power / signal	red
Axis Z, power / signal	white
Common (all channels)	black
N/C	shield

Accessories supplied: #11085 captive screw (International customers specify mounting requirements); calibration data (level 2)
 Accessory available: SF8-8 Cementing pad, 10-32, keyed

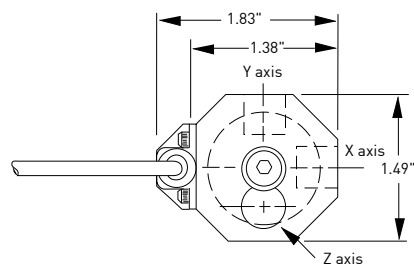

Top view

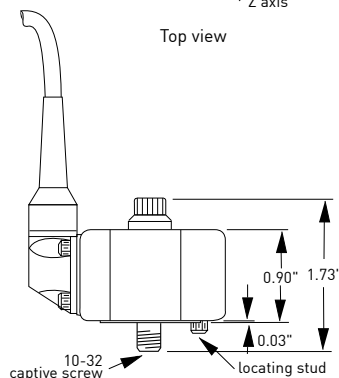

Side view

ALTHEN reserves the right to vary the foregoing details without prior notice



ALTHEN GmbH Mess- und Sensortechnik

Frankfurter Strasse 150 - 152
 65779 Kelkheim / Germany

phone: +49 (0)6195 70060
 fax: +49 (0)6195 700666

sales@althensensors.com
 www.althensensors.com