

# DMU

## Six Degree of Freedom Inertial Sensor Assembly



The DMU combines angular rate and linear acceleration sensors to create full six degree-of-freedom inertial measurement for comprehensive motion sensing and control. The DMU offers an excellent solution for testing, instrumentation and trials, suitable for automotive and related markets.

Using Silicon Sensing's proven MEMS ring gyro technology the DMU offers unsurpassed accuracy and reliability in an affordable package. Angular rate and acceleration data is supplied by the DMU, continuously or on demand.

The DMU also provides a cost effective solution for many other commercial applications requiring a complete six degree-of-freedom motion sensing module.

### Key Features

- A compact unit, providing vehicle Roll, Pitch, Yaw (P,Q,R) plus longitudinal, lateral and vertical (X,Y,Z) acceleration
- 16-bit Digital Signal Processor, incorporating 'on the fly' vector transformation and calibration correction
- Full scale dynamic range  $\pm 250^\circ/\text{s}$  and  $\pm 8g$



© Silicon Sensing is an Atlantic Inertial Systems, Sumitomo Precision Products joint venture company

# DMU

## Six Degree of Freedom Inertial Sensor Assembly

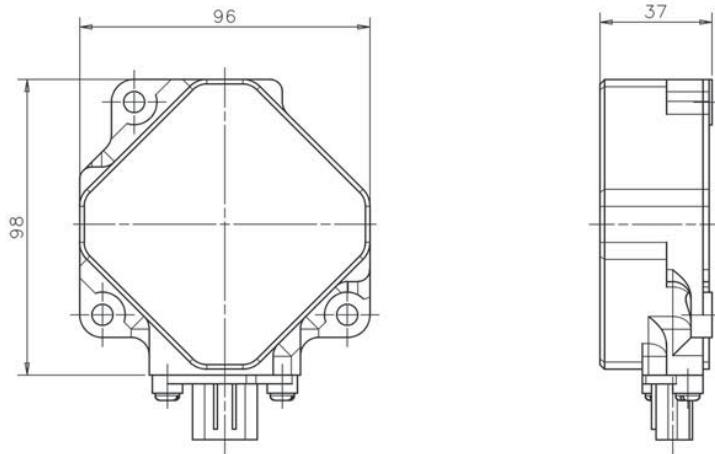

All measurements in millimetres.

### Typical Data

Output format	CAN2B (1Mbps)
Output rate	Polled or free running (every 1ms)
Default message format	PQR/XYZ and sample number
Supply voltage	Vehicle battery (nom. 14.4V) 8V to 20V
Operating temperature range	-20°C to +60°C
Start-up time	< 3s

### Pin Connections

1	+V
2	0V
3	CAN_L
4	CAN_H
5	0V (internally connected to Pin 2)

Angular Rate Function	
Rate range	$\pm 250^\circ/\text{s}$
Resolution	0.008°/s/bit
Scale factor error	< $\pm 3\%$ (including nonlinearity)
Bias variation over temperature	< $\pm 2^\circ/\text{s}$
Bandwidth (-3dB)	> 45Hz
Rate noise (in 20Hz bandwidth)	< 0.25°/s rms

Linear Acceleration Function	
Range	$\pm 8g$
Resolution	0.3mg/bit
Scale factor error	< $\pm 3\%$
Scale factor linearity error	< $\pm 1\%$
Bias error over temperature	< $\pm 0.1g$
Bandwidth (-3dB)	> 100Hz
Acceleration noise (in 20Hz bandwidth)	< $\pm 0.03g$ rms

<b>RoHS Compliant</b>	No
-----------------------	----

Specification subject to change without notice.

© Copyright 2009  
Silicon Sensing Systems Limited  
All rights reserved.  
Printed in England 02/09

Silicon Sensing Systems Limited Registered in England & Wales No. 3635234 Clittaford Road, Southway, Plymouth, Devon PL6 6DE  
The device mark Silicon Sensing is a registered trade mark of Silicon Sensing Systems Community Trade Mark 003587664

CIM00-15-0100-131 Rev 1  
DCR No. 615662



### ALTHEN GmbH Mess- und Sensortechnik

Frankfurter Strasse 150 - 152  
65779 Kelkheim / Germany

phone: +49 (0)6195 70060  
fax: +49 (0)6195 700666

sales@althensensors.com  
www.althensensors.com