



Models P703B Three Channel Power Unit

FEATURES:

- 3 channels
- Powers three separate 700 Series accelerometers and DC decouples the output
- Battery powered (line adaptor optional)
- Battery condition light
- Uses common 9 VDC transistor batteries
- Can drive up to 50 ft. of cable

SPECIFICATIONS

INPUT CHARACTERISTICS

Voltage to Transducer	27 VDC ¹
Current to Transducer, $\pm 20\%$	2.4 mA DC
Maximum Input Voltage	10 V rms

OUTPUT CHARACTERISTICS

Output Impedance (accelerometer attached to input)	same as transducer
Recommended Load Impedance	>100 k Ω

TRANSFER CHARACTERISTICS

Frequency Response	same as transducer
Channels	3
Channel Separation	>80 dB

BATTERY TEST CIRCUIT

LED Lights	>18 VDC
Battery Life	>40 hours

POWER REQUIREMENTS

Batteries	(3) 9V alkaline
-----------------	-----------------

ENVIRONMENTAL

Temperature Range	0 to 55°C
-------------------------	-----------

PHYSICAL CHARACTERISTICS

Size	3" width, 2.4" height, 4" depth
Weight	0.84 lb
Connectors:	
Signal Input	BNC
Signal Output	BNC

- NOTES:**
- ¹ 25.2 VDC when using Ni-Cad batteries.
 - ² For extended operation, the NC3 Ni-Cad Battery Kit should be used (see accessories section).

OPTIONS: • Model P703BT for use with Models 733 and 993 triaxial accelerometers.

ACCESSORIES SUPPLIED: (3) 9V alkaline batteries.

ACCESSORIES AVAILABLE: NC3 Ni-Cad battery kit; LA704B (110V) Line Adaptor; LA704B-220 (220V) Line Adaptor; BNC Series adaptors



Model P703B Operating Instructions

Product Features and Connections

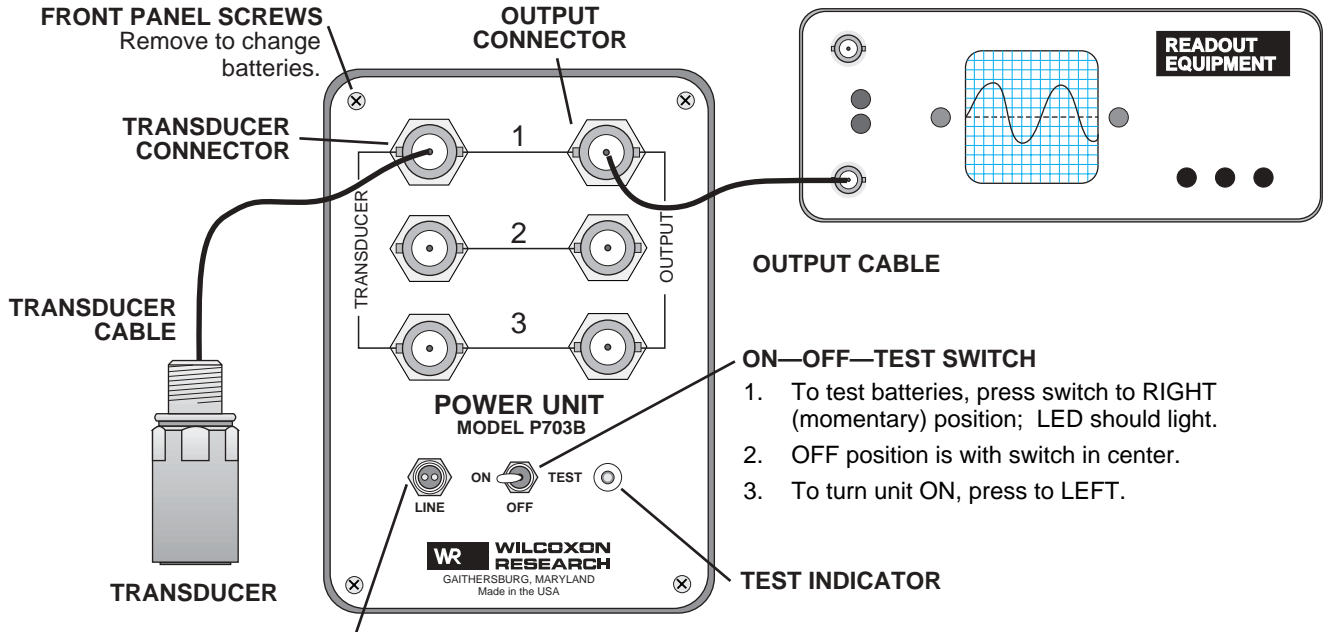

LINE ADAPTOR JACK

Use LA704B Line Adaptor to power unit from line voltage without batteries installed or to charge NiCad batteries.

CAUTION: DO NOT ATTEMPT TO RECHARGE ALKALINES WITH THE LA704B. Alkaline batteries may EXPLODE or leak corrosive fluids.

Test for Proper Operation

To check the Model P703B for proper operation:

- Use a digital multimeter to verify that the proper voltage and current are available at the transducer connector.
- Substitute an Oscillator for the transducer.
- Follow the connection to the power unit as shown at right.
- The unit should have unity gain.

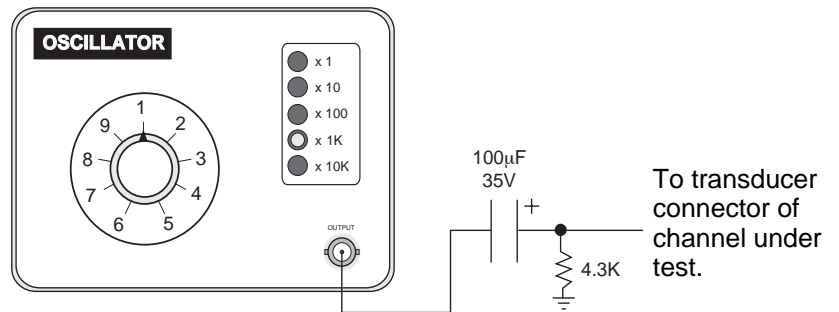

—FOR TECHNICAL ASSISTANCE—

Please contact your Applications Engineer at Wilcoxon Research, Inc.
1-800-WILCOXON • 301-330-8811 • Fax 301-330-8873



Features

- Powers most 700 series accelerometers
- Battery powered (line adaptor optional)
- Portable and lightweight
- Battery condition light
- Uses readily available 9 VDC batteries

Model P704B General purpose power unit

Input characteristics

Voltage to transducer	27 VDC ¹
Current to transducer, ±20%	2.4 mA DC

Output characteristics

Output impedance	same as transducer
Recommended load impedance	>100 kΩ
Decoupling cap	22 μV, 35 VDC

Transfer characteristics

Frequency Response	same as transducer
--------------------------	--------------------

Battery test circuit

LED lights	>18 VDC
Battery life	>120 hours

Power requirements

Batteries ²	(3) 9V alkaline
------------------------------	-----------------

Environment

Temperature range	0 to 55°C
-------------------------	-----------

Physical characteristics

Size	3" W x 2.4" H x 4" D
Weight	0.84 lb.

Connectors:

signal input	BNC
signal output	BNC

Notes: ¹ 25 VDC when using NiCad batteries.

² For extended operation the NC3 NiCad Battery Kit should be used (see accessories section).

Accessories supplied: (3) 9V alkaline batteries

Accessories available: NC3 Ni-Cad battery kit; LA704B (110V) Line Adaptor; LA704B-220 (220V) Line Adaptor; BNC Series adaptors



Model P704B operating instructions

Product features and connections

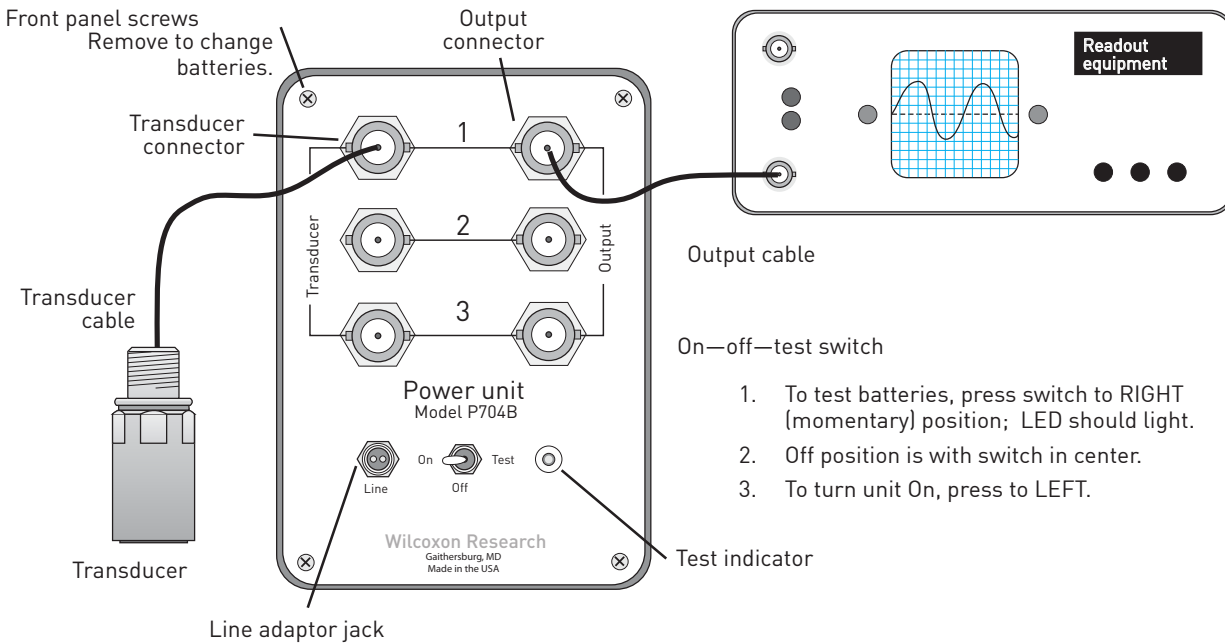

Use LA704B line adaptor to power unit from line voltage without batteries installed or to charge NiCad batteries.

CAUTION: DO NOT ATTEMPT TO RECHARGE ALKALINES WITH THE LA704B. Alkaline batteries may EXPLODE or leak corrosive fluids.

Test for proper operation

To check the model P704B for proper operation:

- Use a digital multimeter to verify that the proper voltage and current are available at the transducer connector.
- Substitute an Oscillator for the transducer.
- Follow the connection to the power unit as shown at right.
- The unit should have unity gain.

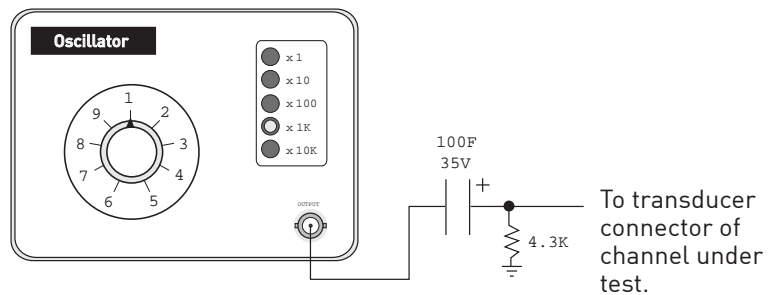

We reserve the right to vary the foregoing details without prior notice