



## bar SPC4050 Pressure Calibrator

The SPC4050 pressure calibrator is designed to provide automated calibration of Scanivalve DSA, ZOC, and MPS series pressure scanners. The calibration system consists of 3 components:

1. The heart of the calibration system is the Scanivalve pressure calibrator, model SPC4050. The SPC4050 calibrator has up to two independent precision pressure regulators. Each regulator can have up to two gauge or absolute transducers; thus up to 4 transducers per calibrator. Transducers can be quickly removed for calibration or service. The transducers are Gauge (psig) or Absolute (psia). Full Scale Gauge pressure ranges are available between 0.36 psig and 750 psig.

2. Scanivalve's Pneumatic Logic Unit (SPCPLU) is required for automated DSA, ZOC, and MPS calibrations. This unit contains the pneumatic solenoid valves and manifolds required to perform single or multi-range calibrations, as well as zero offset corrections.

3. A utility program, PressCal is included with the SPC4050. It performs automated or manual calibrations on all DSA and ZOC pressure scanners by controlling the pressure calibrator and SPCPLU. The PressCal program is hosted in a Windows® environment. PressCal updates the module calibration coefficient files and generates "as received" and calibration validation reports

### FEATURES

- 0.01% F.S. accuracy
- Up to 4 calibration ranges, 0.36 to 750 psig, 0 to 750psia.
- Based on Mensor CPC6050 automated pressure calibrator
- Removable/interchangeable transducers
- Color touch screen
- Automated DSA, ZOC, and MPS calibrations
- Bench or rack mount
- Direct replacement for SPC4000 calibrators



SPC4050 System

### APPLICATIONS

This SPC4050 pressure calibrator is based on the Mensor Corp. model CPC6050 pressure calibrator with specific changes made to work with Scanivalve products. These changes include additional digital outputs to control the SPCPLU as well as modified OEM firmware to accept Scanivalve commands.

In order to perform multipoint calibrations and zero offset corrections on demand to DSA, ZOC, and MPS pressure scanners, the calibrator must be used with the SPCPLU. The reference side of the gauge transducers can be connected to an alternate remote location (tunnel static, elevated line pressure, static basket, etc).

The calibration system can be used for many applications including multi-point calibration of DSA ZOC, and MPS pressure scanners, zero offset correction, and leak testing.

The calibrator can also be used in the local/manual mode utilizing the front panel touch screen or remotely via Ethernet. It would be used in this standalone mode to regulate and measure pressures to calibrate individual pressure transducers. It could be used to send known pressures to all of the DSA, ZOC, and MPS sensors to ensure they are reading correctly (System Validation).



## MODULAR CALIBRATOR DESIGN

The SPC4050 brings a high degree of flexibility by having a variety of configurations available. It can have one or two independent pressure regulators providing two pressure outputs. Each regulator can have up to two transducers. Each regulator module contains all of the calibration, characterization, communication functions and information needed to communicate the pressure reading to the system electrical module. Transducer modules can be easily removed or replaced. Compatible spare transducers of the same or different range can be interchanged to increase utilization.



*Calibrator Chassis*



*Regulator*



*Transducers*

## THE REGULATOR

The SPC4050 has four unique pressure regulators available depending on transducer ranges selected. The Pump Regulator utilizes a pump to both generate and regulate pressure. It can generate pressures as low as 0.5 psia and is generally used when extreme precision is

needed at very low gauge pressures or when an external pressure source is not available.

The other 3 regulators are determined by the range of calibrator transducers selected. The appropriate regulators will be matched for the specific transducer pressure ranges. These regulators require an external pressure source that is approximately 10% above the full scale range of the highest internal pressure range.

### Gauge (psig)

Available Regulators	Min	Max
<b>Pump-Very low pressure</b>	0-0.36	0-15
<b>Low Pressure</b>	0-1	0-50
<b>Medium Pressure</b>	0-10	0-150
<b>High Pressure</b>	0-75	0-750

All regulators can be tuned in the field to meet a specific customer external volume requirement. Specific control requirements, such as control speed, overshoot, and external volume, are just a few of the variables the regulator is able to accommodate.

## CALIBRATOR TRANSDUCER

The transducers are configured in a proprietary process characterizing each pressure range over temperatures from 15 to 45° C. This process has been optimized to provide the greatest accuracy, stability, and reliability. Each range is calibrated with NIST traceable primary standards and provided with a calibration certificate. Transducers 15 psi and above have an uncertainty of +/- .01% F.S. with a one year calibration interval. Transducers 14.9 psi to 1 psi have an uncertainty of +/- .01% F.S. with a one year calibration interval. Transducers less than 1 psi have an uncertainty of +/- .03% F.S. with a one year calibration interval.

### Standard Transducer Ranges

Gauge Transducer	Gauge Transducer
0.36 psig	100 psig
1 psig	200 psig
5 psig	300 psig
15 psig	500 psig
30 psig	750 psig
50 psig	



## STANDALONE/MANUAL CALIBRATION

Manual calibrations can be performed with the SPC4050 by using either the color touch screen or remote commands via Ethernet. This manual mode using remote commands can be used with Scanivalve's DSA, ZOC and MPS pressure scanners. When calibrating individual pressure transducers, the touch screen or remote commands may be used.

The color touch screen provides an intuitive user interface that can be configured in 17 different languages.

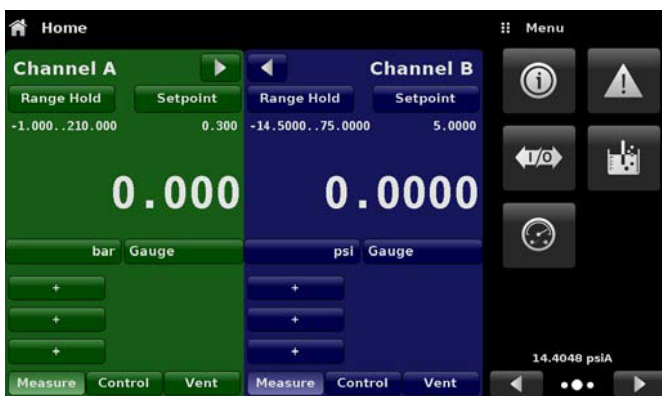

## SPCPLU AUTOMATED CALIBRATION

### FEATURES

- Contains leak tight pneumatic valves
- Works with 1 to 4 pressure ranges
- Works in conjunction with Scanivalve's SPC4050 pressure calibrator
- Facilitates automated and manual DSA, ZOC, and MPS calibrations

### GENERAL DESCRIPTION

The calibrator system consists of 3 components:

1. SPC4050 calibrator
2. The Pneumatic Logic Unit (SPCPLU) is a box that contains pneumatic solenoid valves and manifolds required to perform single or multi-range DSA & ZOC calibrations, as well as zero offset corrections. It also switches the DSA or ZOC calibration valve into sense, calibrate, purge, and leak test modes.
3. Scanivalve's PressCal software program orchestrates the pressure calibrator and SPCPLU to perform automated and manual calibrations.

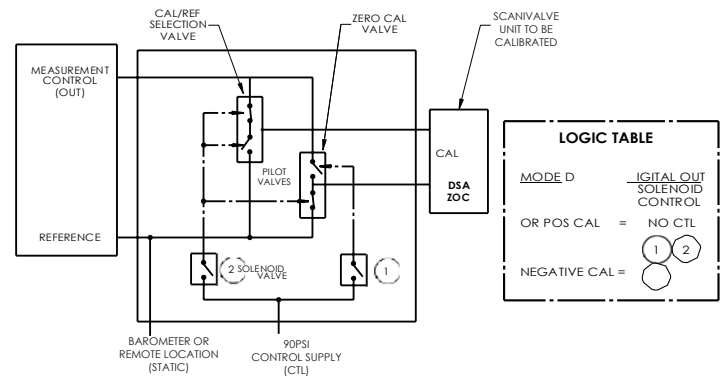

## APPLICATIONS

The SPCPLU is controlled by the SPC4050 pressure calibrator. The unit incorporates piloted high flow pneumatic valves that support:

- Multi-point calibrations of DSA and ZOC pressure scanners for up to 4 pressure ranges
- Positive or below atmospheric (vacuum) calibrations
- Zero offset correction on demand
- Leak testing of system, DSA, ZOC, or MPS pressure scanners



SPCPLU shown

Solenoid valves direct the pressure for the piloted valves when digital output commands are issued. The SPCPLU is designed to work in conjunction with the SPC4050 calibrator to auto calibrate DSA, ZOC, and MPS pressure scanners.

**Models:** SPCPLU-1 supports 1-2 pressure ranges

SPCPLU-2 supports 1-4 pressure ranges

**Power:** SPCPLU receives power from SPC4050

**Weight:** SPCPLU-1 6.9 lbs. (3.13kg) SPCPLU-2 11.5 lbs. (5.22kg)

**Communication:** SPC4050- Ethernet TCP/IP

SPCPLU- Controlled by SPC4050 digital outputs

### Pneumatic

**Connectors:** 1/4 inch Swagelok® fittings

### Solenoid Supply

**Pressure:** 90-120 psi (user supplied, 65 psi optional)

**Pressure range:** 750 psi maximum

**Dimensions:** 19" wide X 3.5" tall X 13" deep  
(48.3cm wide X 8.9cm tall X 33cm deep)



## ■ SPC4050 CALIBRATOR SPECIFICATIONS

**Measurement Units:** psi, inHg, inH2O, ftH2O, ATM, bar, mbar, mmH2O, cmH2O, cmHg, Torr, kPa, Pa, Mpa, PSF, C. Other units and 2 user-defined units are also available.

**Resolution:** 4 to 6 significant digits, user selectable

**Communications:** Ethernet

**Warm-up:** Approximately 30 minutes to achieve full accuracy depending on the environment

**Local User Interface-Display:** 8.9" color LCD display with a resistive touch screen

**Case Dimensions:** 16.86" wide x 6.97" high x 16.37" deep (42.8 cm x 17.7 cm x 41.6 cm)

**Weight:** 36 lbs. (16.33 kg) with all internal options

**Pressure Media:** Clean, dry, non-corrosive, non-combustible, non-oxidizing gases — not suitable for oxygen use

**Operating Temperature Range:** 0°C to 50°C. Note: The compensated temperature range is 15°C to 45°C

**Pneumatic Interface:** 1/4 inch Swagelok® fittings

**Power Requirement:** 100-240 VAC, 47-63 Hz, 75 VA

**Compliance:** The SPC4050 (Mensor CPC6050) complies with RoHS, EN61326-1:A1:1998, EN61326-1:A2:2001, EN55024:1998, and EN61010-1-1

## ■ CALIBRATION INTERVAL

Recommended SPC4050 calibration intervals are: 14.9 psi and below every 6 months. 15 psi and above once per year. The calibrator has firmware for field calibration. A dead weight tester is required for field calibration or the SPC4050 may be returned to Scanivalve's factory for calibration.

## ■ ORDERING INFORMATION

Scanivalve's technical sales staff is available to guide you in the selection of an appropriate regulator and transducers to meet your test calibration requirements. This process involves optimizing the mix of ranges to allow calibration of all of your DSA, ZOC, and MPS pressure scanners.

Choose the calibrator transducer ranges needed to calibrate your transducers or pressure scanners. Standard ranges (gauge) are shown in the table below.

0.36 psig	1 psig	5 psig	15 psig	50 psig
100 psig	200 psig	300 psig	750 psig	

## ■ COMPLETE ORDERING DESCRIPTION (EXAMPLE)

Scanivalve model SPC4050/ 50, 100, 300, 500 psig plus note if you want optional internal barometer.

SPC4050 Options:

### 1. Additional/Spare Transducers

Additional transducers can be purchased. Although transducers will work in any regulator, the range of the regulator must be considered to insure optimum performance.

### 2. Barometric Reference Transducer

The barometric reference transducer is an absolute pressure device used to accurately measure local atmospheric pressure. The barometric reference has an uncertainty of 0.01% of full scale with a recommended calibration interval of 6 months. It can be specified with any SPC4050 configuration.

### 3. Pneumatic Distribution Panel

This product incorporates up to 5 pressure regulators for applying and setting pressures manually on large pressure measurement systems. It manages the pressures that are fed into the SPC4050. This unit is rack mounted.