



DMU41-02

High Performance MEMS Inertial Measurement Unit



FEATURES

- Precision 6-DOF MEMS Inertial Measurement Unit
- Silicon Sensing's class leading VSG3QMAX inductive gyro and dual-axis capacitive accelerometer MEMS
- Excellent Bias Instability and Random Walk
Angular - 0.1°/hr, 0.02°/vhr
Linear - 15µg, 0.05m/s/vhr
- Non-ITAR
- Compact and lightweight - 50.5 x 50.5 x 51.0 (mm), <170g
- Internal power conditioning to accept 4.75V to 32V input voltage
- External synchronisation (PPS external trigger)
- RS485 & RS422 interface and sync pulse output
- -40°C to +85°C operating temperature range
- Low power consumption <2.5W
- Sealed aluminium housing (IP67)
- Designed to support RTCA/DO-178/DO-254/ DO-160G certification
- RoHS compliant
- In-house manufacture from MEMS fabrication to IMU calibration
- Evaluation kit and integration resources available
- First class customer technical support
- Fixed interface

APPLICATIONS

- Guidance, navigation and control (Space, Air, Land, Sea, Subsea)
- MEMS alternative to FOG/RLG IMUs
- Platform/camera/antenna stabilisation
- GPS drop-out aiding
- GNSS (Global Navigation Satellite System)
- Airborne, land-based and hydrographic survey and mapping
- AHRS (Attitude and Heading Reference System)
- INS (Inertial Navigation Systems)
- Small satellite stabilisation and attitude control
- Autonomous vehicles, UAVs and ROVs
- Machine control and motion measurements
- Launch vehicle

1 GENERAL DESCRIPTION / 1.1 OVERVIEW

DMU41 is a class leading high performance six-degree of freedom Inertial Measurement Unit (IMU). It represents the next generation of a family of High Performance IMUs that incorporate an optimised suite of Silicon Sensing’s unique resonating ring gyroscopes and capacitive accelerometers.

DMU41 fuses the outputs from three inductive and three piezoelectric (PZT) resonating ring gyroscopes, to provide three orthogonal measurements of angular rate. The DMU41 also fuses outputs from two independent accelerometers along each axis to provide three orthogonal measurements of linear acceleration.

The unique multi-sensor architecture enables the sensor outputs to be optimally blended to achieve benchmark, all-MEMS inertial performance, providing a realistic alternative to established FOG/RLG based IMUs. DMU41 provides exceptional angle random walk and bias instability coupled with low noise characteristics.

DMU41 has been designed specifically to meet the growing demand for high-end applications requiring a ‘tactical grade’ IMU without being ITAR controlled. Each DMU41 is calibrated over the full operational temperature range using Silicon Sensing’s in-house state-of-the-art test facility. Silicon Sensing Systems is a market leader in silicon MEMS gyroscopes, accelerometers and inertial measurement systems, specialising in high performance, reliability and affordability. Silicon Sensing has a strong heritage in inertial sensing that can be traced back over 100 years. All sensors are based on in-house patented designs which are produced in its own state of the art MEMS foundry. Over 40 million sensors have been delivered to thousands of satisfied customers worldwide, and Silicon Sensing continues to drive performance through technical expertise and continuous innovation.

1.2 INERTIAL SENSORS

The inertial sensing core of DMU41 has two gyros and two accelerometers on each of the three principal axes. Refer to Figure 1.1 DMU41 Functional Block Diagram. Angular rate on each of the X, Y and Z IMU axes is sensed by a combination of one CRH03 high-precision Inductive-MEMS gyro and one PinPoint® CRM-series high dynamic PZT-MEMS gyro. Six gyros in total. Linear acceleration on each of the X, Y and Z IMU axes is sensed by three dual-axis, high-integrity Gemini® MEMS accelerometers, effectively providing two accelerometers per axis.

The IMU software includes ‘blending’ algorithms to combine the outputs of the multiple sensors per axis in order to achieve higher motion sensing performance and integrity. The low-bias instability CRH03 gyro has a dynamic measurement range of 200°/s to allow better measurement sensitivity within the normal motion of the host system, yet by utilising the PinPoint® CRM gyro the IMU is capable of operating at up to 490°/s to allow excursions from the normal motion without loss of data.

Another unique feature of DMU41 is dual-axis acceleration sensing. Having two independent MEMS accelerometers measuring linear acceleration means that common-mode errors can be largely eliminated resulting in higher performance acceleration measurement. More information on the sensor operating principles can be found in Section 12.

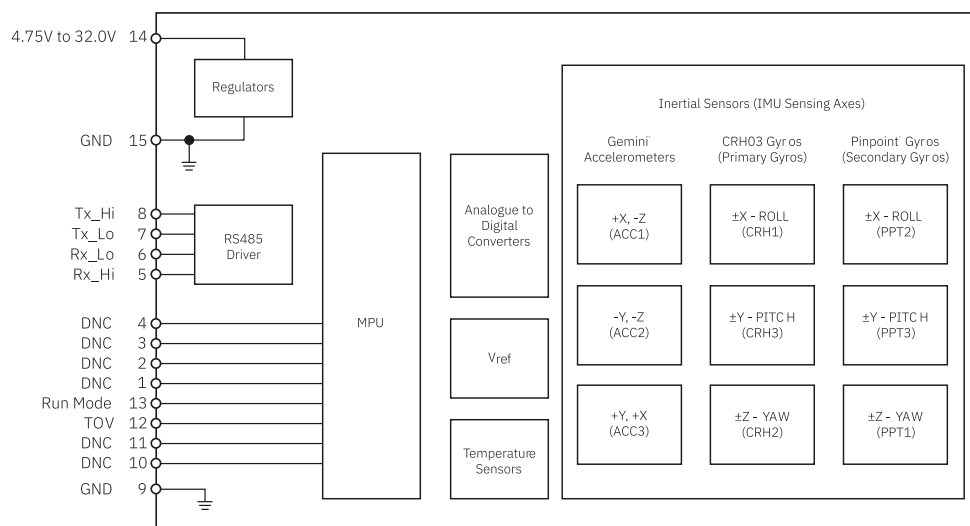
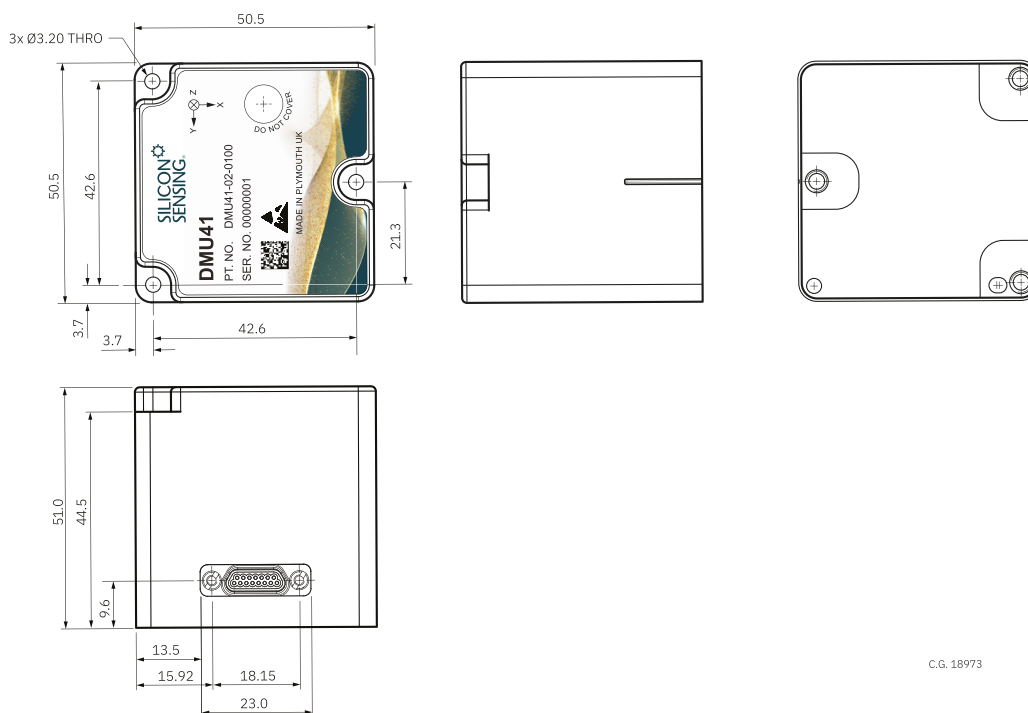

Figure 1.1 DMU41 Functional Block Diagram

OUTLINE CONSTRUCTION (UNIT: mm)







c.g. 18973

All dimensions in millimetres
External dimensions are MAX

Figure 1.2 DMU41 Unit Overall Dimensions

ORDERING INFORMATION

Item	Description	Overall Dimensions	Part Number
 DMU41-01 IMU	High Performance MEMS Inertial Measurement Unit (USER CONFIGURABLE interface version)	50.5 x 50.5 x 51.0 mm	DMU41-01-0100
 DMU41-02 IMU	High Performance MEMS Inertial Measurement Unit (FIXED interface version)	50.5 x 50.5 x 51.0 mm	DMU41-02-0100
 DMU41 Evaluation Kit	Customer Evaluation Kit (EVK) comprising an RS422 to USB Connector, USB Driver and Data Logging Software, Cables and Connectors (DMU41 is NOT included)	Not Applicable	DMU41-00-0500
 DMU41 Mating Connector	Mating connector plug and cable for DMU41	Length 450 mm	Glenair MWDM2L-15P-6E5-18 or equivalent

**SPECIFICATION**

Parameter	Minimum	Typical (1 σ) unless stated otherwise	Maximum	Notes
Angular (Roll, Pitch, Yaw)				
Dynamic Range (°/s)	-490	-	+490	Clamped at ± 495 °/s during over-range
Scale Factor Error (ppm)	-700	± 240	+700	Over life
Scale Factor Non-Linearity Error (ppm)	-500	± 170	+500	Up to ± 200 °/s
	-1500	± 500	+1500	Between ± 200 °/s and ± 490 °/s
Bias (°/hr)	-20	± 7	+20	Over operating temperature range. Factory fresh test and during warranty period
	-30	± 7	+30	Over operating temperature range over life
Bias Instability (°/h)	-	< 0.1 (Mean)	< 0.2	As measured using the Allan Variance method.
Random Walk (°/√h)	-	< 0.02 (Mean)	0.04	
Bias Repeatability (°/h)	-	17	50	Bias Repeatability = $\sqrt{(\text{Bias}_{\text{arm}})^2 + (\text{Bias}_{\text{drift}})^2 + (\text{Bias}_{\text{aging}})^2 + (\text{Bias}_{\text{temperature}})^2}$
Gyro Cross Coupling (%)	-0.4	± 0.13	+0.4	Over operating temperature range
Sensor Level Bandwidth (Hz)	-	150	-	-3dB point
IMU Level Bandwidth (Hz)	> 77	-	-	-3dB point
Noise (°/s rms)	-	0.05	0.1	Wideband noise to 100Hz
VRE (°/s/g ² rms)	-0.006	± 0.002	+0.006	4.2g rms stimulus 20Hz to 2000Hz
g Sensitivity (°/hr/g)	-0.1	± 0.033	+0.1	Tested over $\pm 10g$



■ SPECIFICATION CONTINUED

Parameter	Minimum	Typical (1 σ) unless stated otherwise	Maximum	Notes
Linear (X, Y, Z)				
Dynamic Range (g)	-10	-	+10	Clamped at $\pm 11.0g$ during over-range
Scale Factor Error (ppm)	-500	± 170	+500	Maximum error at $\pm 1g$
Scale Factor Error (ppm) Over Life	-1000	± 333	+1000	Maximum error at $\pm 1g$. Over life
Scale Factor Non-Linearity Error (ppm)	-5000	± 1700	+5000	Maximum error from best straight line calculated at $\pm 1g$ (over $\pm 10g$ range)
Bias (mg)	-5.00	± 1.70	+5.00	Over operating temperature range. Factory fresh test and during warranty period
	-7.00	± 1.70	+7.00	Over operating temperature range over life
Bias Instability (μg)	-	15	30	As measured using the Allan Variance method.
Random Walk (m/s/ \sqrt{h})	-	0.05	0.06	
Bias Repeatability (mg)	-	2.3	7	Bias Repeatability = $\sqrt{(Bias_{warmup})^2 + (Bias_{start})^2 + (Bias_{aging})^2 + (Bias_{temperature})^2}$
Acc Cross Coupling (%)	-0.42	± 0.13	+0.40	Over operating temperature range
Sensor Level Bandwidth (Hz)	-	250	-	-3dB point
IMU Level Bandwidth (Hz)	>77	-	-	-3dB point
Noise (mg rms)	-	0.9 (Mean)	1.4	Wideband noise to 100Hz
VRE (mg/g ² rms)	-0.15	± 0.05	+0.15	4.2g rms stimulus 20Hz to 2000Hz when measured with zero g background acceleration
Temperature Output				
Range (°C)	-45	-	100	Note that this exceeds operational temperature range
Accuracy (°C)	-	± 2	-	Represents the internal DMU41 temperature

**ENVIRONMENT, POWER AND PHYSICAL / 4.1 NORMAL OPERATION**

Parameter	Minimum	Typical (1 σ)	Maximum	Notes
Environment				
RTCA/DO-160G	Tested and in compliance with the environmental requirements of DO-160G			
Operating Temperature Range (°C)	-40	-	+85	Full specification
Storage Temperature Range (°C)	-55	-	+100	-
Operational Shock (g)	-	-	95	6ms, half sinewave. Also shock tested in accordance with DO-160G.
Operational Shock (g) (powered survival)	-	-	1000	1.0ms, half sinewave. (Note 3). Also shock tested in accordance with DO-160G.
Operational Random Vibration (g rms)	-	-	4.2	20Hz to 2kHz
Non-Operational Random Vibration (g rms)	-	-	10.6	20Hz to 2kHz
Humidity (% rh)	-	-	85	Non-condensing
Sealing	IP67	-	-	The DMU41 is sealed and tested to IP67
Environmental Protection				
Audio Frequency Conducted Susceptibility (power inputs)	-	Section 18 Category Z	-	RTCA/DO-160G (Note 1)
Induced Signal Susceptibility	-	Section 19 Category ZWX	-	RTCA/DO-160G
RF Susceptibility (radiated and conducted)	-	Section 20 Category S	-	RTCA/DO-160G
Emission of RF Energy	-	Section 21 Category B	-	RTCA/DO-160G (Note 2)

**4.1 NORMAL OPERATION CONTINUED**

Parameter	Minimum	Typical (1 σ)	Maximum	Notes
Electrical and Interface				
Communication Protocol (standard)	-	RS485, RS422	-	Full duplex communication
Data Rate (Hz)	-	200 (default)	-	-
Baud Rate (BPS)	-	460800 (default)	-	-
Start-up Time (s) (operational output)	-	< 1.0	1.2	Time to operational output
Start-up Time (s) (full performance)	-	-	20	Time to full performance (mounting dependent)
Quiescent Power (Watts)	-	-	<2.5	With 120 Ω RS485 termination resistor
Supply Voltage (V)	+4.75	+12	32	Unit is calibrated at 12V Note that operation at 4.75V requires a low impedance supply with short interconnects
Physical				
Size (mm)	-	50.5 x 50.5 x 51.0	-	-
Mass (grams)	-	<170	-	-

Note 1: DMU41 has been tested in accordance with RTCA/DO-160G section 18 category Z. DMU41 is sensitive to frequencies matching the internal sensor operating frequencies which are 13500Hz to 14500Hz, plus the submultiples of 1/2 and 1/3.

Note 2: DMU41 exceeds D0160G Section 21.4 Category B Conducted RF Emissions limits at 300kHz on the 28V supply line. Additional power line conditioning (EMI filtering) may be required to suppress this depending on host system requirements.

Note 3: This is a survival test. Following exposure to High G shock, linear scale factor performance may degrade by a factor of 3.

Note 4: DMU41 is designed to survive short-term immersion in water, up-to the IP67 standard. To maintain integrity around the connector, it is essential that the mating connector is a sealed type, or a suitable sealing compound should be applied around the connector.

Note 5: The in-rush current required for start up increases with decreasing supply voltage. Therefore, for low supply voltages a supply with a low source impedance is required. Also short cables are recommended.

Note 6: Voltages should not be applied to any I/O pin when unit is unpowered.

Note 7: **Overranging the DMU41 supply voltage may cause significant damage to the IMU.**



4.2 ABSOLUTE MINIMUM/MAXIMUM RATINGS

	Minimum	Maximum
Electrical:		
Vdd	Reverse voltage protected	+32V
ESD protection	-	IEC 61000-4-2 with chassis externally connected to 0V
Life:		
Operational life	5 years	-
MTTF	20000 hours	-

Note 1: Improper handling, such as dropping onto hard surfaces, can generate very high shock levels in excess of 10000g. The resultant stresses can cause permanent damage to the sensor.

Note 2: Exposure to the Absolute Maximum Ratings for extended periods may affect performance and reliability.

4.3 COMPLIANCE

- AS9100D
- ISO14001
- ISO17025

RoHS

UK REACH

EMC Performance to RTCA/DO-160-G:

- Section 18 Cat Z
- Section 19 Cat ZW
- Section 20.4 Cat S
- Section 20.5 Cat S
- Section 21.4 Cat B
- Section 21.5 Cat B



5 TYPICAL PERFORMANCE CHARACTERISTICS

This section shows the typical performance of DMU41, operating from a 12V power supply.

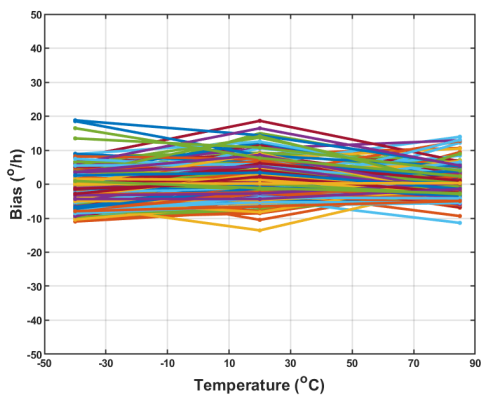

Figure 5.1 Gyro Bias Error (°/h) over Temperature

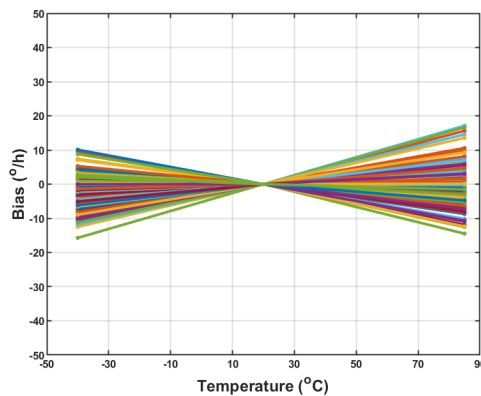

Figure 5.2 Normalised Gyro Bias Error (°/h) over Temperature

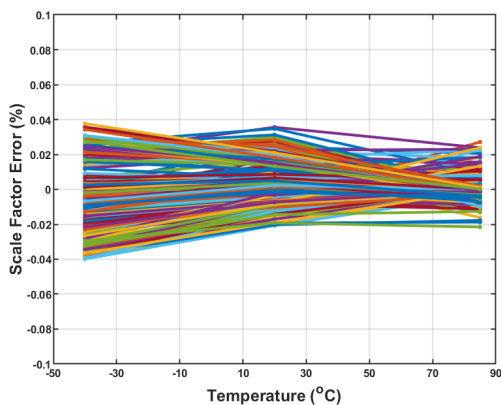

Figure 5.3 Gyro Scale Factor Error over Temperature

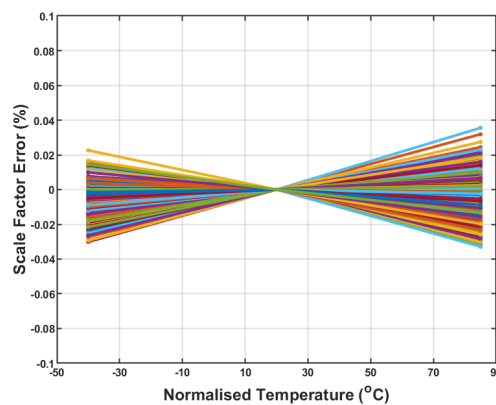

Figure 5.4 Normalised Gyro Scale Factor Error over Temperature

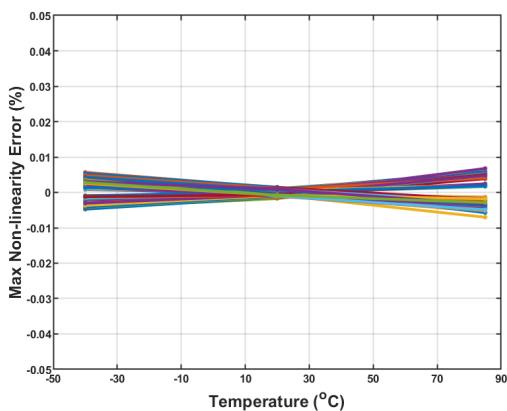

Figure 5.5 Gyro Max Non-Linearity Error (±490°/s range) over Temperature

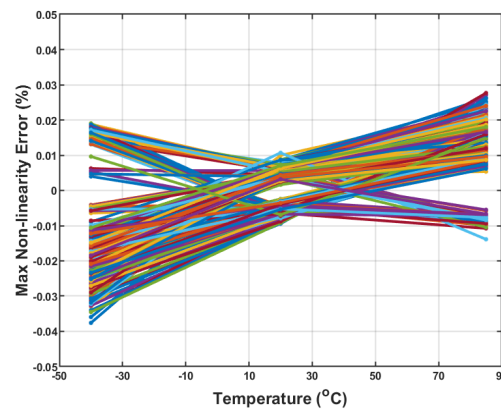

Figure 5.6 Gyro Max Non-Linearity Error (±200°/s range) over Temperature

5 TYPICAL PERFORMANCE CHARACTERISTICS CONTINUED

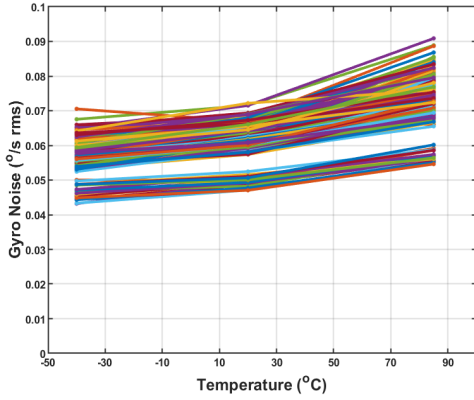

Figure 5.7 Gyro Noise (°/s rms) vs Test Chamber Temperature

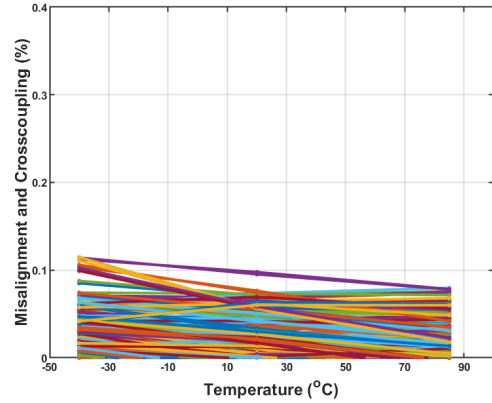

Figure 5.8 Gyro Misalignments and Crosscoupling ($\pm 200^\circ/\text{s}$ range) over Chamber Temperature

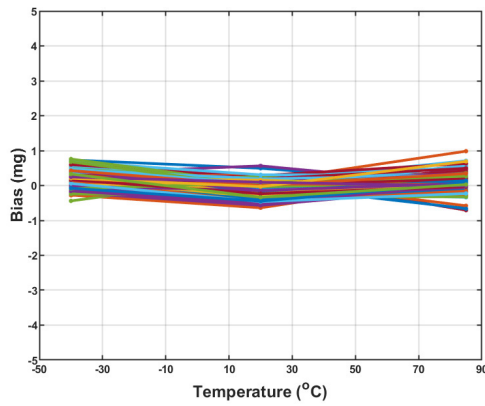

Figure 5.9 Accelerometer Bias Error (mg) over Temperature

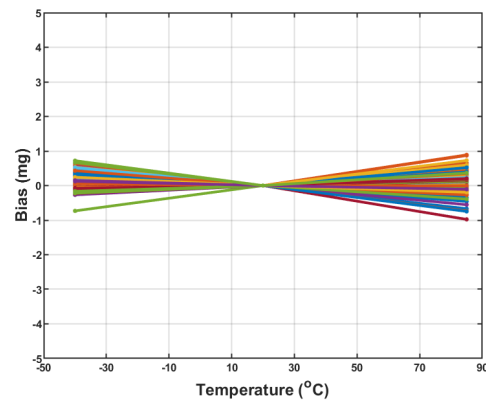

Figure 5.10 Normalised Accelerometer Bias Error (mg) over Temperature

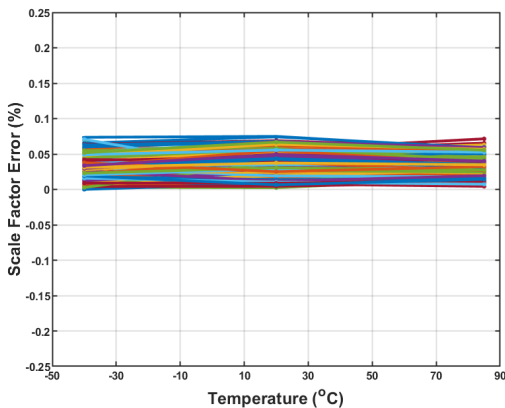

Figure 5.11 Accelerometer Scale Factor Error ($\pm 1g$ range) over Temperature
(Plymouth $g = 9.81058m/s/s$)

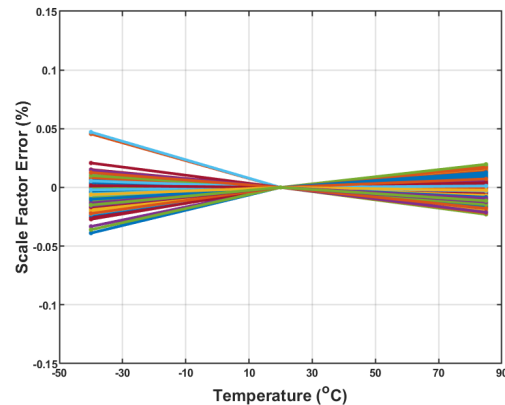

Figure 5.12 Normalised Accelerometer Scale Factor Error ($\pm 1g$ range) over Temperature

5 TYPICAL PERFORMANCE CHARACTERISTICS CONTINUED

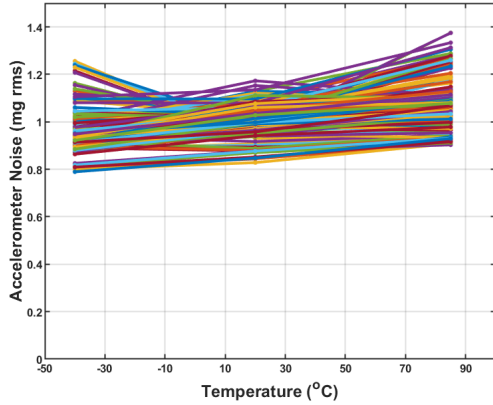

Figure 5.13 Accelerometer Noise vs Test Chamber Temperature

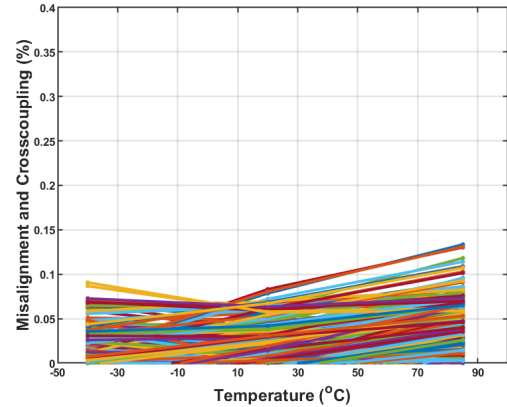

Figure 5.14 Accelerometer Misalignments and Crosscoupling over Temperature

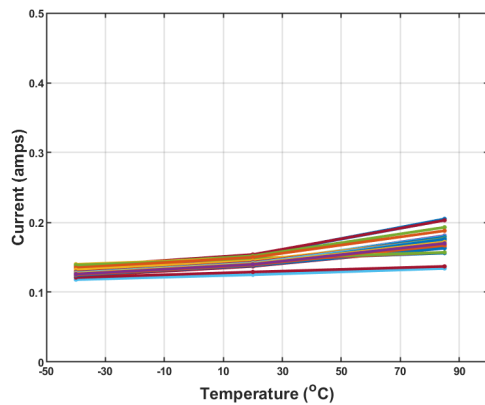

Figure 5.15 Current Consumption vs Chamber Temperature (12V supply)

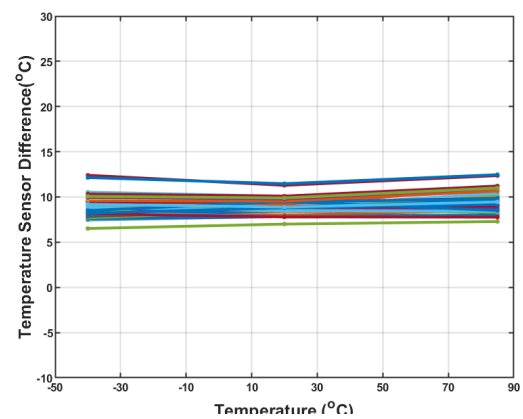

Figure 5.16 DMU41 Temperature Output Difference (°C) vs Test Temperature (self heating)

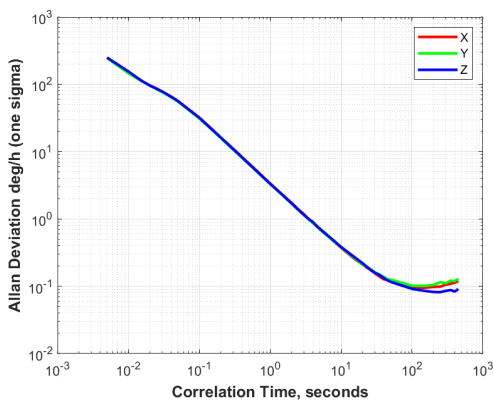

Figure 5.17 Gyro Allan Variance

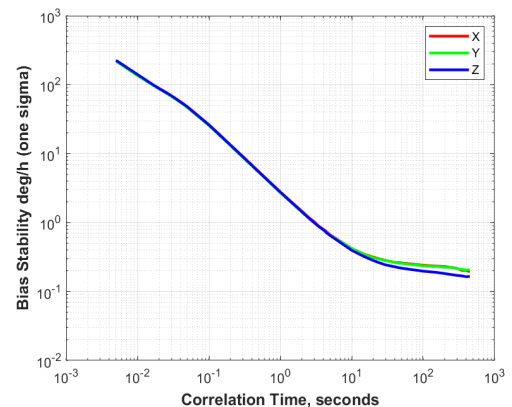

Figure 5.18 Gyro In Run Stability



5 TYPICAL PERFORMANCE CHARACTERISTICS CONTINUED

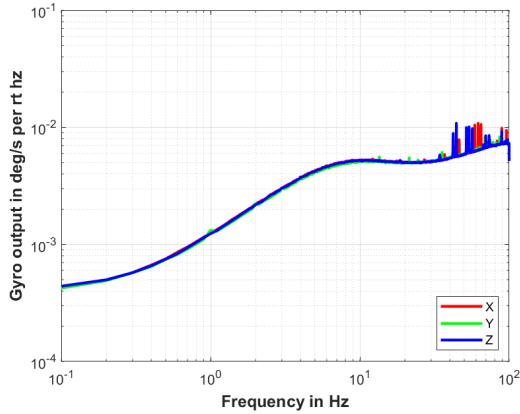

Figure 5.19 Gyro Spectral Data

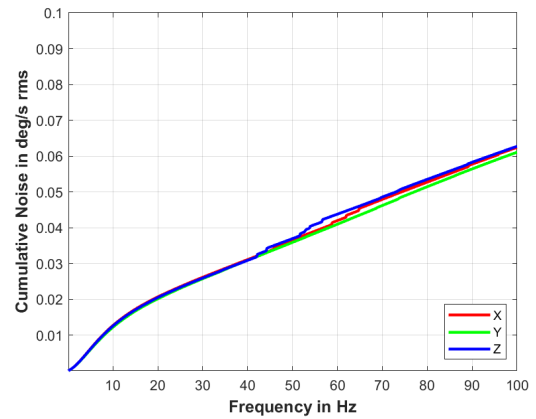

Figure 5.20 Gyro Cumulative Noise

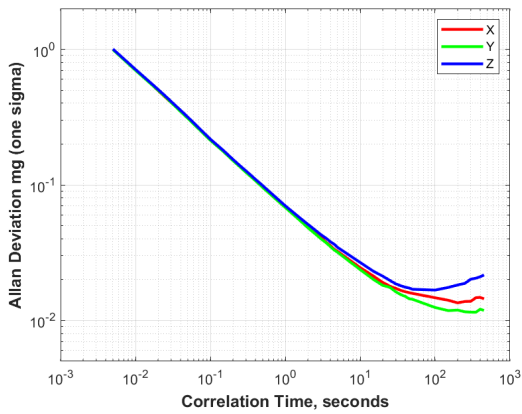

Figure 5.21 Accelerometer Allan Variance

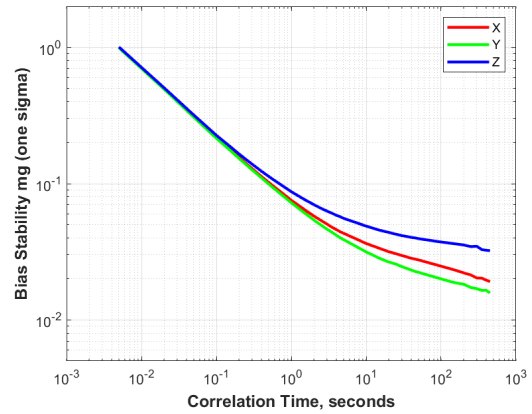

Figure 5.22 Accelerometer In Run Stability

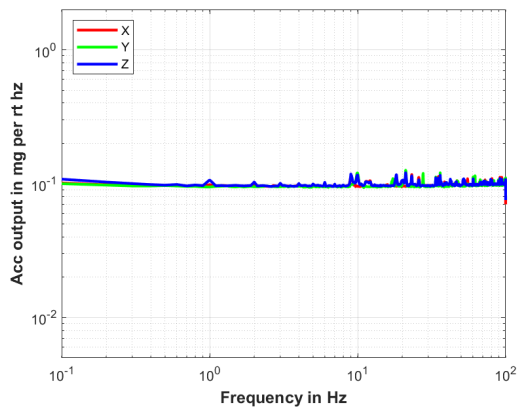

Figure 5.23 Accelerometer Spectral Data

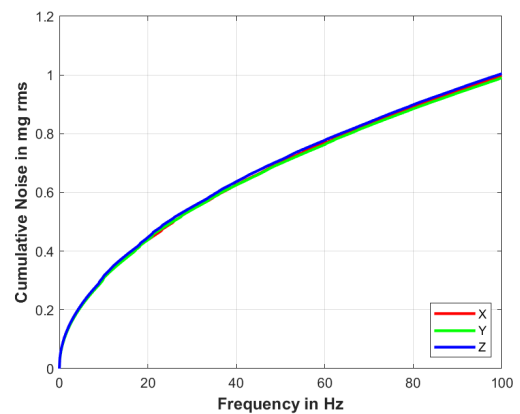
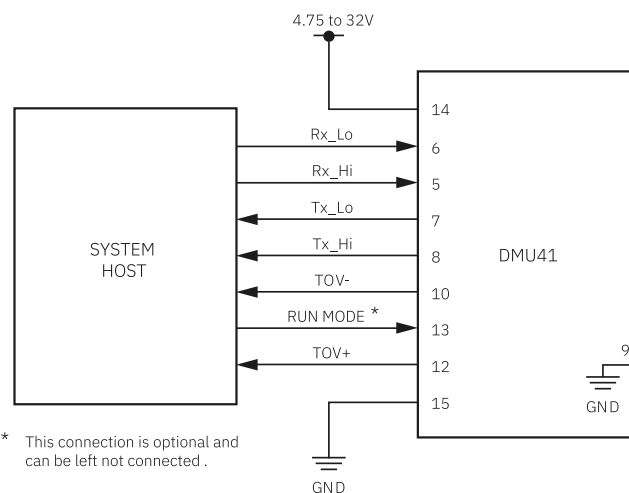

Figure 5.24 Accelerometer Cumulative Noise

6 GLOSSARY OF TERMS

ACC	Accelerometer / Acceleration	RoHS	Restriction of Hazardous Substances
AGC	Automatic Gain Control	RTCA	Radio Tech. Commission for Aeronautics
AHRS	Attitude Heading Reference System	SD	Secondary Drive
BIT	Built-In-Test	TOV	Time of Validity
BPS	Bits Per Second	UAV	Unmanned Aerial Vehicle
BS	British Standard	UNC	Unified Coarse
CAD	Computer Aided Design	USB	Universal Serial Bus
DNC	Do Not Connect	VCO	Voltage-Controlled Oscillator
DOF	Degrees of Freedom	VRE	Vibration Rectification Error
DRIE	Deep Reactive Ion Etch		
EMC	Electro-Magnetic Compatibility		
EMI	Electro-Magnetic Interference		
ESD	Electro-Static Damage		
EVK	Evaluation Kit		
FOG	Fibre Optic Gyro		
FP	Fixed Point		
GNSS	Global Navigation Satellite System		
GPS	Global Positioning System		
Hz	Hertz, Cycles Per Second		
IMU	Inertial Measurement Unit		
INS	Inertial Navigation System		
I / O	Input / Output		
ITAR	International Traffic in Arms Regulation		
MDS	Material Datasheet		
MEMS	Micro-Electro Mechanical Systems		
MEV	External USB to serial converter		
MPU	Microprocessor Unit		
MTTF	Mean Time To Failure		
NVM	Non-Volatile Memory		
PC	Personal Computer		
PD	Primary Drive		
PLL	Phase Locked Loop		
ppm	parts per million		
PPS	Pulse Per Second		
RAM	Random Access Memory		
REACH	Registration, Evaluation, Authorisation and Restriction of Chemicals		
RF	Radio Frequency		
RLG	Ring Laser Gyro		
rms	root mean squared		

7 INTERFACES / 7.1 ELECTRICAL INTERFACE



NOTE 1: Pins 1, 2, 3 & 4 should not have an input connected .
 NOTE 2: If the TOV interface is not used, pins 10 & 12 should not be connected .

C.G. 18964

Figure 7.1 Required Connections for RS485 Communications with DMU41

7.2 ELECTRICAL CONNECTOR PINOUT

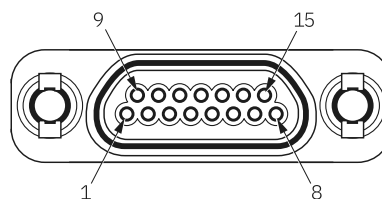

15-Way Micro-Miniature Connector Type DCCM-15 S
 Use 2-56 UNC Jackscrews when connecting Plug T type DCCM-15P

C.G. 18884

Figure 7.2 DMU41 Socket Connector (Top View)

7.3 CONNECTOR SPECIFICATION

DMU41 uses a 15-way socket connector which is the micro-miniature 'D' type range of connectors, produced by Cinch, Glenair and others.

The DMU41 plug mating connector is a 15 way plug, for example DCCM-15P (DCCM-15P6E518).

Silicon Sensing can supply a mating plug and cable to interface to DMU41 or they are available from electronic component distributors. The part is available from RS, Stock No: 612-6489.

2-56 UNC Female Jackposts are used on the DMU41 connector. 2-56 UNC Jackscrews should be used for connecting to this. A kit is available from RS, Stock N^o: 719-5928.

7.4 PIN INFORMATION

Pin	Label	Signal	In/Out	Nominal Range	Absolute Max
1	DNC	DNC	DNC	DNC	DNC
2	DNC	DNC	DNC	DNC	DNC
3	DNC	DNC	DNC	DNC	DNC
4	DNC	DNC	DNC	DNC	DNC
5	Rx_Hi	+ve Rx RS485	I	2.9V to +3.3V	0V to +32V
6	Rx_Lo	-ve Rx RS485	I	2.9V to +3.3V	0V to +32V
7	Tx_Lo	-ve Tx RS485	O	2.9V to +3.3V	0V to +32V
8	TX_Hi	+ve Tx RS485	O	2.9V to +3.3V	0V to +32V
9	GND	Power Return for the DMU41	-	-	-
10	TOV-	-	O	3.3V	0V to 4V
11	Factory Use	Used by SSSL for programming purposes and should not be connected	N/A	3.3V	0V to 9V
12	TOV+	-	O	3.3V	0V to 4V
13	Run Mode	-	I	3.3V	0V to 4V
14	+Volts	Input voltage to the DMU41 can be between 4.75V and 32V with respect to GND	-	-	4.75V to 32V
15	GND	Power Return for the DMU41	-	-	-

7.5 IMU MODE STATES

DMU41 has two IMU mode states: Operational Mode State and Command Mode State. The normal mode state during usage in the host application is the Operational Mode State, and this is the default state during every IMU power up. In the Operational Mode State DMU41 performs and communicates to the host system as per the user configured settings applied while in the Command Mode State.

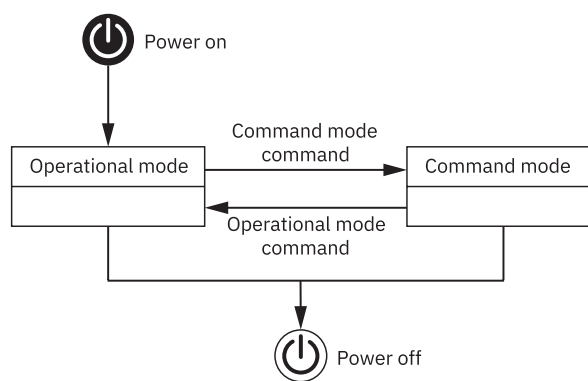

C.G.18936

Figure 7.3 DMU41 IMU States

NOTE: As stated in section 4. Voltages should not be applied to any I/O pin when unit is unpowered.

7.6 SENSOR SAMPLING AND SYNCHRONISATION

Time of validity (TOV) is the mid sample of when the data was averaged, from 1kHz down to 200Hz. The timing is illustrated in Figure 7.4. By default, this output is not enabled but can be enabled to be a differential output, TOV+ and TOV-.

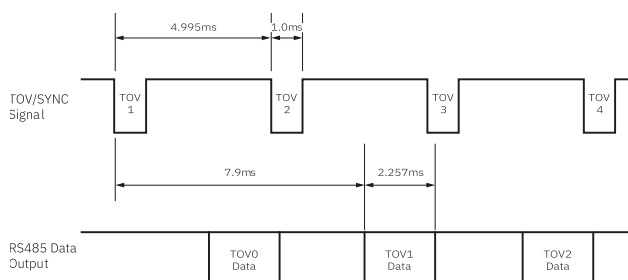

C.G.18862

Figure 7.4 Timing Diagram



Time of Validity Parameters	Requirement
Time of Validity Signal Frequency	200.2Hz
TOV Logic	Active Low
TOV Pulse Width	1ms
TOV Declared Accuracy	<0.5ms
TOV Jitter	<50µs
Delay to Start of Message from TOV Low	<10ms (7.9ms Typical)
Format	RS485 Differential from Pins 1 and 2, Single Ended from Pin 12

Table 7.2 Time of Validity Parameters

The message from the DMU41 is transmitted after the 'Time of Validity'. This enables the external equipment to synchronise with the time when the Inertial Data was valid.

7.7 OPERATIONAL MESSAGE OUTPUT Messages from DMU41 are built to a standard message structure as summarised in Tables 7.3 and 7.4.

Label	Data Type	Data Width (Bytes)	Data Value	Description
Header	Integer	2	0x55AA	Start of message indicator
Count	Integer	2	0 - 65535	Message count (n)
Body	Dependent on message item (2...n)	2 - 254	Dependent on message item (2...n)	Message item data bytes. Always a minimum of 2 data items as system start up and operational built in test flag message items are non-configurable
Checksum	Integer	2	0 - 65535	Checksum of message

Table 7.3 DMU41 Output Message Structure

7.7.1 MESSAGE BODY

Item	Word	Data Item	Value / Unit
0	0	Header	16 Bit, 0x55AA
1	1	Message Count	16 Bit, 0 to 65535 decimal
2	2-3	Axis X Rate	32 Bit Single Precision FP, (°/s)
3	4-5	Axis X Acceleration	32 Bit Single Precision FP, (g)
4	6-7	Axis Y Rate	32 Bit Single Precision FP, (°/s)
5	8-9	Axis Y Acceleration	32 Bit Single Precision FP, (g)
6	10-11	Axis Z Rate	32 Bit Single Precision FP, (°/s)
7	12-13	Axis Z Acceleration	32 Bit Single Precision FP, (g)
8	14-15	Aux Input Voltage	32 Bit Single Precision FP, (volts)
9	16-17	Average IMU Temperature	32 Bit Single Precision FP, (°C)
10	18-19	Axis X Delta Theta	32 Bit Single Precision FP, (°)
11	20-21	Axis X Delta Vel	32 Bit Single Precision FP, (m/s)

Item	Word	Data Item	Value / Unit
12	22-23	Axis Y Delta Theta	32 Bit Single Precision FP, (°)
13	24-25	Axis Y Delta Vel	32 Bit Single Precision FP, (m/s)
14	26-27	Axis Z Delta Theta	32 Bit Single Precision FP, (°)
15	28-29	Aux Z Delta Vel	32 Bit Single Precision FP, (m/s)
16	30	System Start-up Bit Flags	16 Bit decimal value
17	31	System Operation Bit Flags	16 Bit decimal value
18	32	Error Operation Bit Flags	16 Bit decimal value
19	33	Checksum	16 Bit 2's Complement of the 16 Bit Sum of the Previous 0-18 data items

Table 7.4 Operational Message Data
Output Definitions



7.7.2 CHECKSUM

16 bit two's complement of the 16 bit sum of the previous data items. The checksum consists of the running sum of the following 16-bit words:

- Header
- Count
- Body, where all 32 bit values are broken into blocks of two bytes and added to the running sum

Once all message items have been summed the two's complement is taken and the resulting value appended to the message.

7.7.3 SYSTEM START-UP BUILT IN TEST FLAGS

During initialisation a number of parameters can raise a fault condition. Initialisation or start-up faults are persistent and represented by a bit in the system start-up message. These flags are the result of evaluating the initialisation built in tests. The individual bit allocations are shown in Table 7.5.

BIT	System Start Up Flags
0	Extendable Checksum Fail
1	NVM Coefficient Checksum Fail
2	Sensor Start Up Error
3	Internal Processor Error
4	Invalid NVM Coefficient
5	Reserved
6	Reserved
7	Reserved
8	Reserved
9	Reserved
10	Reserved
11	Reserved
12	Reserved
13	Reserved
14	Reserved
15	Reserved

Table 7.5 DMU41 Start-Up Built in Test Flags

7.7.3 SYSTEM START-UP BUILT IN TEST FLAGS

During normal IMU operation a number of parameters can raise a fault condition. Operational faults are transient and will only be reported against the output message for which the fault was detected. Each fault is represented by a bit in the system operational built in test flags word, these flags are the result of evaluating the operational built in tests. The individual bit allocations are shown in Table 7.5.

BIT	System Operation Flags
0	Voltage Regulator Range Error
1	Scheduler Slot Extended
2	Output Message Missed
3	Internal Processor Error
4	Sensor Operation Error
5	Output Over Range
6	Accelerometer Plausibility Error
7	Reserved
8	Reserved
9	Reserved
10	Reserved
11	Reserved
12	Reserved
13	Reserved
14	Reserved
15	Reserved

Table 7.6 DMU41 Operational Built in Test Flags

7.7.5 SYSTEM ERROR INDICATION BIT FLAGS







During operation, if there is an error detected from one of the sensor outputs, this will be flagged up as a System Error Indication. These are described in Table 7.7.

Bit	Bit Flag Error Indication	Bit	Bit Flag Error Indication
0	Axis X Rate	8	Axis X Delta Theta
1	Axis X Acceleration	9	Axis X Vel
2	Axis Y Rate	10	Axis Y Delta Theta
3	Axis Y Acceleration	11	Axis Y Vel
4	Axis Z Rate	12	Axis Z Delta Theta
5	Axis Z Acceleration	13	Axis Z Vel
6	Aux Input Voltage	14	Reserved
7	Avg IMU Temperature	15	Reserved

Table 7.7 DMU41 Error Indication Built in Test Flags

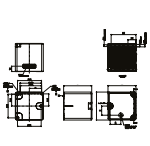

8 DESIGN TOOLS AND RESOURCES AVAILABLE

Item	Description of Resource	Part Number	Order/Download
	DMU41 Brochure: A one page sales brochure describing the key features of the DMU41 Inertial Measurement Unit.	DMU41-00-0100-131	Download (www.siliconsensing.com)
	DMU41 Datasheet: Full technical information on all DMU41 Dynamic Measurement Unit part number options. Specification and other essential information for assembling and interfacing to DMU41 Inertial Measurement Unit.	DMU41-02-0100-132	Download (www.siliconsensing.com)
	Solid Model CAD files for DMU41 Inertial Measurement Unit: Available in .STP file format.	DMU41-00-0100-403_ Iss_1.stp	Download (www.siliconsensing.com)
	DMU41 Installation Drawing: Drawing containing host interface geometry.	DMU41-00-0100-403	Download (www.siliconsensing.com)
	Customer Evaluation Kit (EVK) comprising an RS422 to USB Connector, USB Driver and Data Logging Software, Cables and Connectors (DMU41 is NOT included)	Not Applicable	DMU41-00-0500
	Mating connector plug and cable for DMU41	Length 450 mm	Glenair MWDM2L-15P-6E5-18 or equivalent
	RoHS compliance statement for DMU41: DMU41 is fully compliant with RoHS. For details of the materials used in the manufacture please refer to the MDS Report.	-	-

8.1 DMU41 EVALUATION KIT (EVK)

The DMU41 Evaluation Kit enables the output data from the DMU41 to be viewed and logged for testing and evaluation purposes.



Figure 8.1 DMU41 Evaluation Kit

8.1.1 DMU41 EVALUATION KIT CONTENTS

The DMU41 Evaluation Kit (part number DMU41-00-0500) contains the following:

- MEV RS485i to USB converter.
- Mating plug and cable.
- User manual (downloadable from <http://www.siliconsensing.com>).

Note: DMU41 is NOT included in the EVK, it must be purchased separately.

8.1.2 SYSTEM REQUIREMENTS

The DMU41 Evaluation Kit requires a PC with a USB port. The requirements for the PC are as follows:

- Microsoft® Vista®, Windows 7, Windows 8, Windows 10 or Windows 11, Operating Systems. The software has not been tested on any other Operating System and therefore correct functionality cannot be guaranteed.
- Minimum of 500Mb of RAM.
- 500Mb of free hard drive space plus space for logged data (typical data rate \approx 50kbit/s).
- High power or self-powered USB 2.0 Port.

9 PART MARKINGS

DMU41 is supplied with an adhesive label attached. The label displays readable DMU41 part and serial numbers.

The serial number is a numeric code, YYWWXXXX CC where:

YY = Manufacturing year number

WW = Manufacturing week number

XXXX = Part ID number CC = Revision

A 4x4 data matrix barcode containing the part identification number is also displayed on the label.

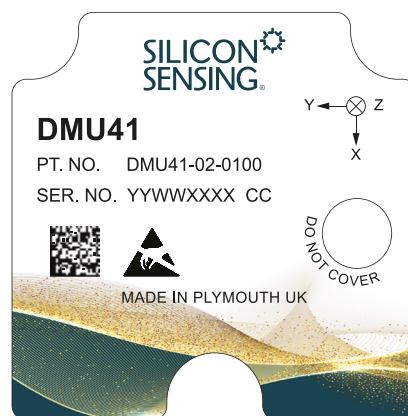

Figure 9.1 DMU41 Label



10 INSTALLATION DETAILS

Figure 10.1 shows the installation drawing for the DMU41. DMU41 is designed to accommodate 3-point mounting from either the top (standard) or bottom (bulkhead) of the unit. Standard M3 screws should be used when standard mounting is used, with a minimum length of 50mm. Bulkhead mounting uses M4 screws, where the thread engagement is located 14.4mm down the length of the hole. There is a thread depth of 8.0mm available for thread engagement.

The use of dowel holes is critical to achieve alignment and repeatability. Alignment of the part should be with respect to these, using dowel pins. The dowel holes are designed to be used with two $\varnothing 3\text{mm}$ (in accordance with BS EN ISO 8734 or BS EN ISO 2338) dowel pins provided by the host.

The DMU41 mounting screw torque settings will be dependent on the host application; it will for example

vary depending on the specification of the screw, the material of the host structure and whether a locking compound is used. The suggested torque setting for securing a DMU41 to an aluminium host structure using steel screws and a thread locking compound is 0.2Nm. This information is provided for guidance purposes only. The actual torque settings are the responsibility of the host system designer. The DMU41 should not be disassembled. This could compromise the calibration and will invalidate the warranty.

Note: The DMU41 housing incorporates a vent to enable a planned future addition of a barometric pressure sensor. This vent is located on the top face of the housing, in the lower right corner of the IMU label. This area is marked 'PLEASE DO NOT COVER'. The vent has a Gore-Tex® seal installed. To maintain enclosure integrity and IP67 rating, the Gore-Tex® seal must not be damaged, altered or covered in any way.

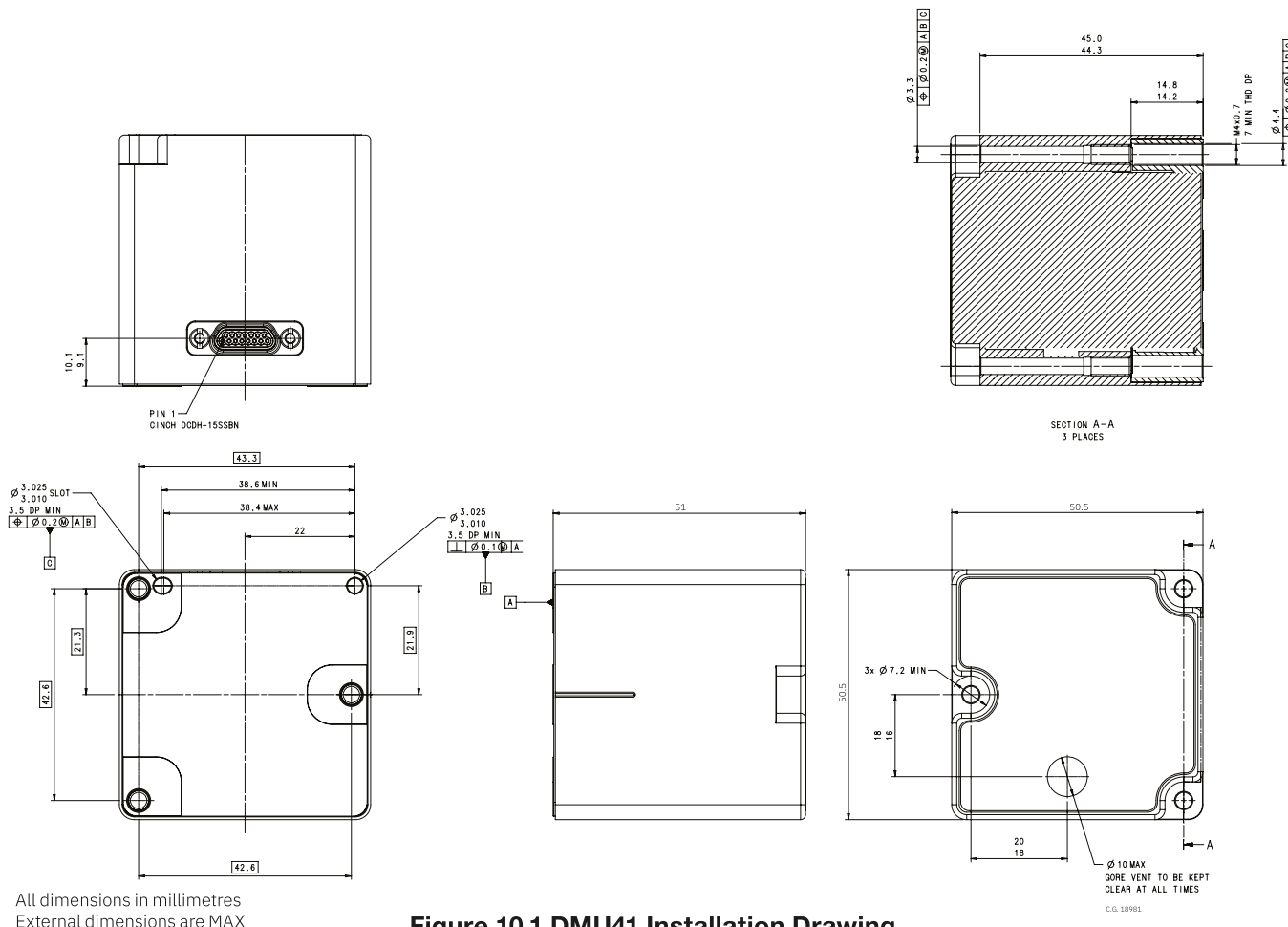

Figure 10.1 DMU41 Installation Drawing

11 AXIS DEFINITIONS AND SENSING POINTS

The DMU41 uses 6 gyroscopes and 6 accelerometers in a paired configuration to optimise performance for each axis. Figure 11.1 shows the axis definitions for the DMU41.

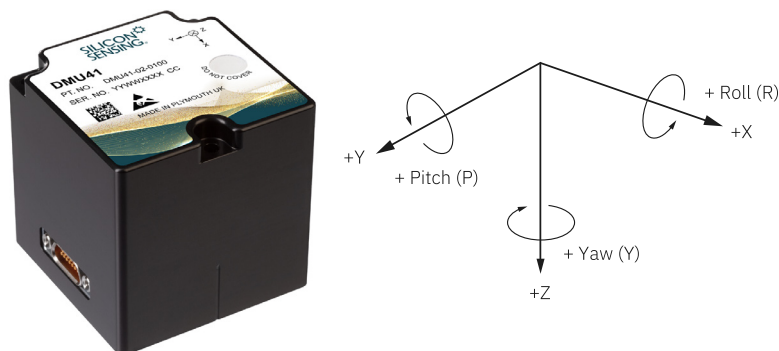

Figure 11.1 Axis Definitions

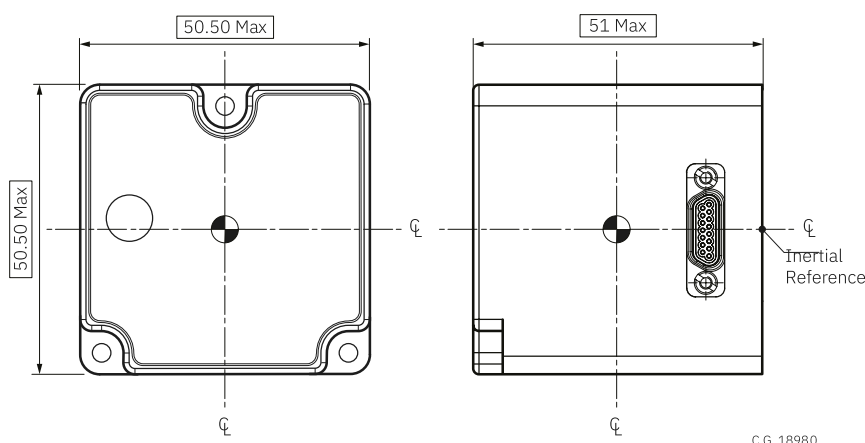

Figure 11.2 Position of the Inertial Reference Point

There are two accelerometers per axis within the DMU41. The sensors used in each axis are orientated to reduce common mode errors and improve noise. Table 11.1 shows the effective mid-point position of the pairs of accelerometers used for each axis. Size effect compensation is not carried out within the DMU41 and these values will enable the user to provide external size effect compensation should this become necessary within the application.

Accelerometer	Sensing Element Position (Relative to Inertial Reference Point), mm		
	X	Y	Z
X Accelerometer	+10.35	+0.6	+10.25
Y Accelerometer	+4.85	-2.80	+26.45
Z Accelerometer	-1.05	-9.2	+23.6

Table 11.1 Accelerometer Sensing Positions

12 DMU41 CONSTRUCTION AND THEORY OF OPERATION / 12.1 IMU CONSTRUCTION

DMU41 is an aluminium alloy assembly comprising base, housing, sensor block, sensor assemblies and IMU electronics.

The base and housing are sealed using a self-forming gasket and secured by three machine screws to provide a waterproof enclosure. A micro-miniature 'D' type socket connector located on the top face of the housing provides the electrical interface to the host system. The top face of the housing displays the DMU41 part marking information.

DMU41 is aligned to the host system using two Ø3mm dowels in the host platform which locate with matching dowel holes in the bottom face of the base. The standard mounting for DMU41 is secured using M3 machine screws, for alternative bulkhead mounting M4 machine screws are used (see Section 10 - Installation Details).

A precision machined aluminium 3-Axis Sensor Block, secured to the DMU41 Base by machine screws provides accurate alignment and support for the DMU41 MEMS inertial sensor assemblies and IMU electronics. Internally generated heat from the sensor assemblies and IMU electronics is absorbed into the sensor block and surrounding housing and conducted to the host via the base and to the ambient atmosphere via the housing.

12.2 SENSOR CONSTRUCTION AND THEORY OF OPERATION

SILICON MEMS INDUCTIVE RING GYROSCOPE

The silicon MEMS ring is 6mm diameter by 100µm thick, fabricated by Silicon Sensing Systems using a DRIE (Deep Reactive Ion Etch) bulk silicon process. The ring is supported in free-space by eight pairs of symmetrical 'dog-leg' shaped legs which support the ring from the supporting structure on the outside of the ring. IMU electronics is absorbed into the sensor block and surrounding housing and conducted to the host via the base and to the ambient atmosphere via the housing.

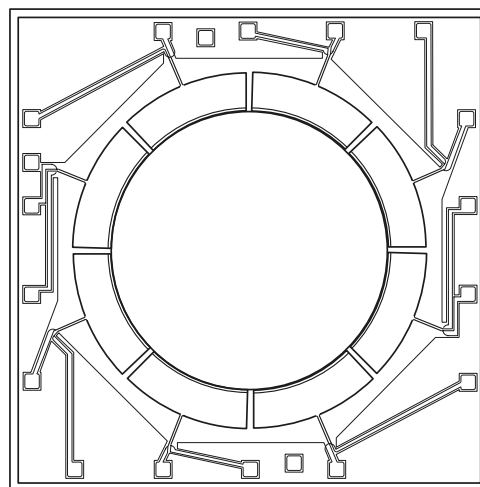

C.G. 18619

Figure 12.1 Silicon MEMS Ring

The bulk silicon etch process and unique patented ring design enable close tolerance geometrical properties for precise balance and thermal stability and, unlike other MEMS gyros, there are no small gaps to create problems of interference and stiction. These features contribute significantly to DMU41's bias and scale factor stability over temperature, and vibration immunity. Another advantage of the design is its inherent immunity to acceleration induced rate error or 'g-sensitivity'.

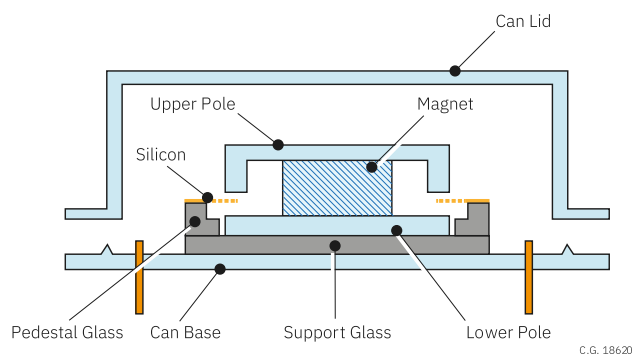

C.G. 18620

Figure 12.2 MEMS VSG3Q^{MAX} Sensor

The ring is essentially divided into 8 sections with two conductive tracks in each section. These tracks enter and exit the ring on the supporting legs. The silicon ring is bonded to a glass pedestal which in turn is bonded to a glass support base. A magnet, with upper and lower poles, is used to create a strong and uniform magnetic field across the silicon ring. The complete assembly is mounted within a hermetic can.

The tracks along the top of the ring form two pairs of drive tracks and two pairs of pick-off tracks. Each section has two loops to improve drive and pick-off quality.

One pair of diametrically opposed tracking sections, known as the Primary Drive PD section, is used to excite the $\cos 2q$ mode of vibration on the ring. This is achieved by passing current through the tracking and, because the tracks are within a magnetic field, causes motion on the ring. Another pair of diametrically opposed tracking sections, known as the Primary Pick-off PP section and are used to measure the amplitude and phase of the vibration on the ring. The Primary Pick-off sections are in the segments 90° to those of the Primary Drive sections. The drive amplitude and frequency is controlled by a precision closed loop electronic architecture with the frequency controlled by a Phase Locked Loop (PLL), operating with a Voltage Controlled Oscillator (VCO), and amplitude controlled with an Automatic Gain Control (AGC) system. The primary loop therefore establishes the vibration on the ring and the closed loop electronics is used to track frequency changes and maintain the optimal amplitude of vibration over temperature and life. The loop is designed to operate at about 14kHz.

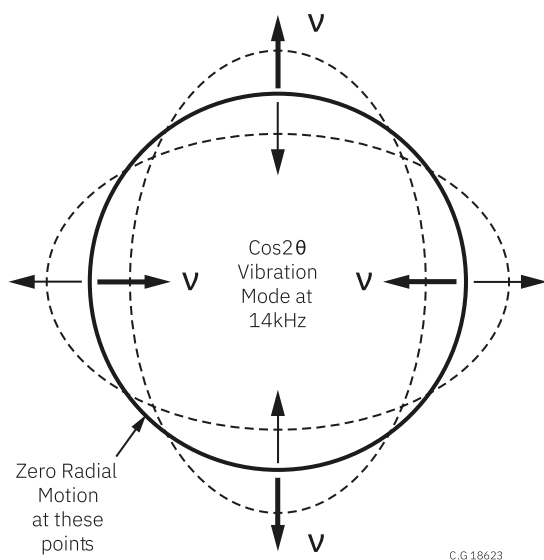
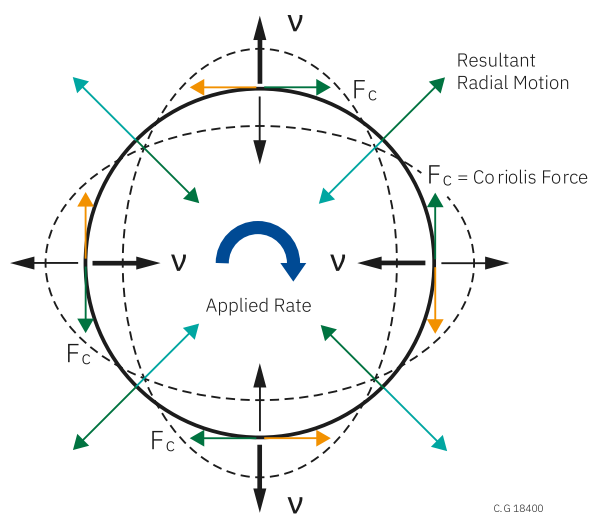

Figure 12.3 Primary Vibration Mode

Having established the $\cos 2q$ mode of vibration on the ring, the ring becomes a Coriolis Vibrating Structure Gyroscope. When the gyroscope is rotated about its sense axis the Coriolis force acts tangentially on the ring, causing motions at 45° displaced from the primary mode of vibration. The amount of motion at this point is directly proportional to the rate of turn applied to the gyroscope. One pair of diametrically opposed tracking sections, known as the Secondary Pick-off SP section, is used to sense the level of this vibration. This is used in a secondary rate-nulling loop to apply a signal to another pair of secondary sections, known as the Secondary Drive SD. The current applied to the Secondary Drive to null the secondary mode of vibration is a very accurate measure of the applied angular rate. All of these signals occur at the resonant frequency of the ring. The Secondary Drive signal is demodulated to baseband to give a voltage output directly proportional to the applied rate in free space.



The closed loop architecture of both the primary and secondary loops results in excellent bias, scale factor and non-linearity control over a wide range of operating environments and life. The dual loop design, introduced into this new Sensor Head design, coupled with improved geometric symmetry, results in excellent performance over temperature and life. The discrete electronics employed in DMU41 ensures that performance is not compromised.

SILICON MEMS CAPACITIVE ACCELEROMETER

The accelerometer contains a seismic ‘proof mass’ with multiple fingers suspended via a ‘spring’ from a fixed supporting structure. The supporting structure is anodically bonded to the top and bottom glass substrates thereby fixing it to the sensor package base.

When the accelerometer is subjected to a linear acceleration along its sensitive axis, the proof mass tends to resist motion due to its own inertia, therefore the mass and its fingers become displaced with respect to the interdigitated fixed electrode fingers (which are also fixed to glass substrates). Air between the fingers provides a damping effect. This displacement induces a differential capacitance between the moving and fixed silicon fingers which is proportional to the applied acceleration.

Capacitor plate groups are electrically connected in pairs at the top and bottom of the proof mass. In-phase and out of phase waveforms are applied by the ASIC separately to the ‘left’ and ‘right’ finger groups. The demodulated waveforms provide a signal output proportional to linear acceleration.

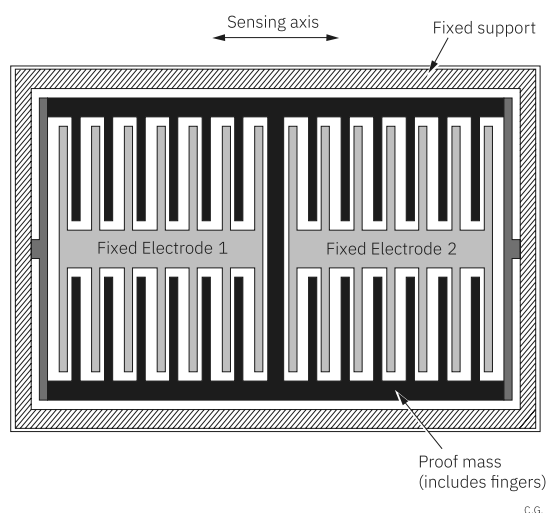

Figure 12.5(a) Schematic of Accelerometer Structure

Figures 12.5(a) and 12.5(b) provide schematics of the accelerometer structure and control loop respectively.

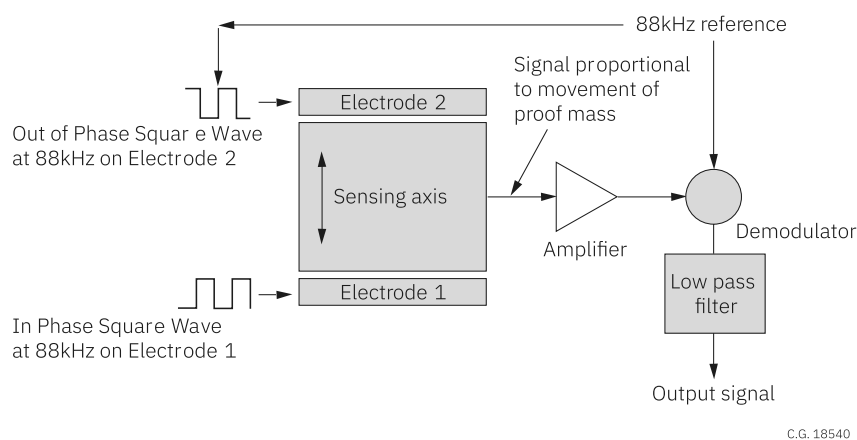

Figure 12.5(b) Schematic of Accelerometer Control Loop