



DMU41 High Performance Inertial Measurement Unit

DMU41 is a class leading high performance Inertial Measurement Unit (IMU). It represents the next generation of a family of High Performance IMUs that incorporate an optimised suite of Silicon Sensing's unique resonating ring gyroscopes and capacitive accelerometers. DMU41 takes the proven performance and reliability of DMU30, but packages it in a 30% smaller form factor with added user functionality.

DMU41 fuses the outputs from three inductive and three piezoelectric resonating ring gyroscopes, along with three dual-axis accelerometers. All of these sensors have been designed and manufactured by Silicon Sensing. The unique multi-sensor architecture enables the sensor outputs to be optimally blended to achieve benchmark, all-MEMS inertial performance, providing a realistic alternative to established FOG/RLG based IMUs. DMU41 provides exceptional angle random walk and bias instability coupled with low noise characteristics.

DMU41 has been designed specifically to meet the growing demand for high-end applications requiring a 'tactical grade' IMU without being ITAR controlled. It is able to provide messages at variable output rates up to 2kHz which can include a combination of angular rate, acceleration, delta angle and delta velocity, temperature and built in test results. Each DMU41 is calibrated over the full operational temperature range using Silicon Sensing's in-house state-of-the-art test facility.

Silicon Sensing Systems is a market leader in silicon MEMS gyroscopes, accelerometers and inertial measurement systems, specialising in high performance, reliability and affordability. Silicon Sensing has a strong heritage in inertial sensing that can be traced back over 100 years. All sensors are based on in-house patented designs which are produced in its own state of the art MEMS foundry. Over 40 million sensors have been delivered to thousands of satisfied customers worldwide, and Silicon Sensing continues to drive performance through technical expertise and continuous innovation.



FEATURES

- Precision MEMS Inertial Measurement Unit
- Silicon Sensing's class leading VSG3QMAX inductive gyro and capacitive accelerometer MEMS
- Excellent Bias Instability and Random Walk:
Angular - 0.1°/hr, 0.02°/vhr
Linear - 15µg, 0.05m/s/vhr
- Non-ITAR
- Compact and lightweight - 50.5 x 50.5 x 51.0 (mm), <178g
- Internal power conditioning to accept 5V to 32V input voltage
- External synchronisation (PPS, external trigger)
- RS422 interface and sync pulse output
- -40°C to +85°C operating temperature range
- User configurable interface
- Low power consumption <1.8W
- Sealed aluminium housing (IP67)
- 3-axis magnetometer output
- Designed to support RTCA/DO-160, DO-178, DO-254 certification
- RoHS compliant
- In-house manufacture from MEMS fabrication to IMU calibration
- Evaluation kit and integration resources available
- First class customer technical support

APPLICATION

- AHRS (Attitude and Heading Reference System)
- Airborne, railway and hydrographic survey and mapping
- INS (Inertial Navigation System)
- Guidance, navigation and control (Space, Air, Land, Sea, Subsea)
- Autonomous vehicles, UAVs and ROVs
- Machine control and motion measurements
- Platform/camera/antenna stabilisation
- MEMS alternative to FOG/RLG IMUs
- Small satellite stabilisation and control
- Launch vehicle
- GNSS (Global Navigation Satellite System)



OUTLINE CONSTRUCTION (UNIT: mm)

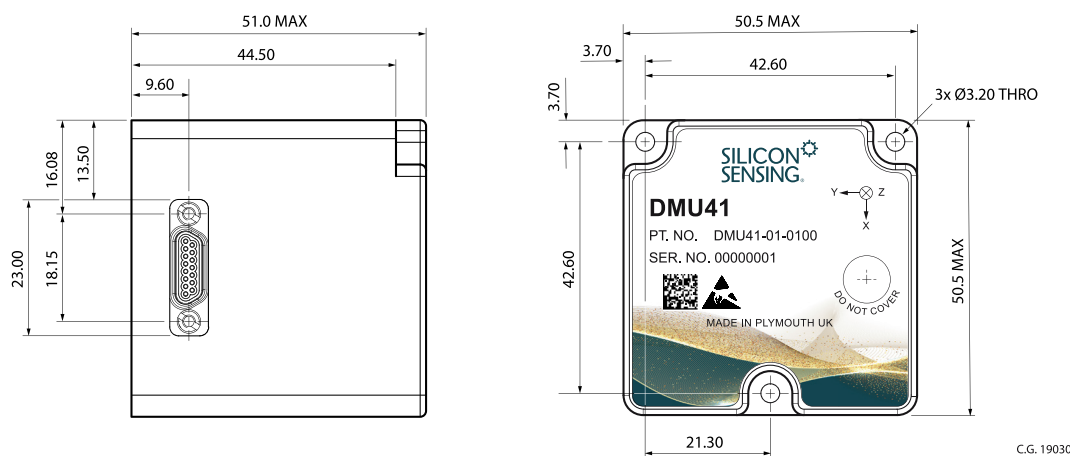

C.G. 19030

TYPICAL DATA

Parameter	Specification
Gyroscope Properties	
Rate range	$\pm 490^\circ/s$
Scale factor over temperature (1σ)	$\pm 240\text{ppm}$
SF non-linearity (up to $\pm 200^\circ/s$) (1σ)	$\pm 170\text{ppm}$
Bias instability (mean)	$< 0.1^\circ/\text{hr}$
Bias over temperature (1σ)	$\pm 7^\circ/\text{hr}$
Noise (up to 100Hz) (rms)	$0.05^\circ/s$
Angle random walk (1σ)	$< 0.02^\circ/\sqrt{\text{hr}}$
Accelerometer Properties	
Acceleration range	$\pm 10g$
Scale factor over temperature ($\pm 1g$) (1σ)	$\pm 170\text{ppm}$
SF non-linearity ($\pm 10g$) (1σ)	$\pm 1700\text{ppm}$
Bias instability (1σ)	$< 0.015\text{mg}$
Bias over temperature (1σ)	$\pm 1.7\text{mg}$
Noise (up to 100Hz) (rms)	0.90mg
Velocity random walk	$< 0.05\text{m/s}/\sqrt{\text{hr}}$
Misalignment	
Cross-axis sensitivity (1σ)	$\pm 0.13\%$
IMU Temperature Sensor Properties	
Range	-45°C to 100°C
Accuracy at temperature (1σ)	$\pm 2^\circ\text{C}$
IMU Properties and Features	
Operating temperature	-40°C to 85°C
Start-up time (full performance)	$< 1.0\text{s}$ ($< 20\text{s}$)
Supply voltage	5 to 32V
Power (at ambient)	$< 1.8\text{W}$
Mass	< 178 grams
User configurable interface	Yes



DMU41 EVK Evaluation Kit
(P/N DMU41-00-0500)