

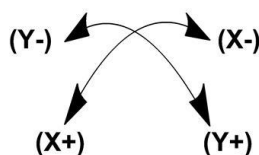

**A875**  
Mini "Tuff Tilt" Digital Tiltmeter

The model 875 Mini "Tuff Tilt" Tiltmeter combines high precision and durability in a miniaturized and economical instrument package. Using MEMS technology, the 875 delivers superior measurement accuracy with virtually no long-term drift and a resolution of 0.05°. Output options include 0.5-4.5Vdc, 4-20mA and digital RS485. All units are rated IP67 waterproof for advanced protection from the elements. Use the 875 Mini "Tuff Tilt" for structural monitoring, angle measurement and control, platform leveling, testing and research, OEM and more. This product is RoHS compliant.



Static / Dynamic			
Angular Range <sup>1</sup>	±5°	±15°	±30°
Resolution	0.05°	0.05°	0.05°
Output Voltage Range (Vdc)	0.5-4.5	0.5-4.5	0.5-4.5
FRO Tolerance (% max)	±0.30	±0.30	±0.30
Scale Factor (V/°)	0.4000 ±0.0012	0.1333 ±0.0004	0.0667 ±0.0002
SF Temp Coefficient (ppm/°C, max)	±150	±150	±150
0° Output (V max @ room temp.)	±0.03	±0.03	±0.03
0° Temp Coefficient (V/°C max)	±0.005	±0.005	±0.005
Non-linearity (% FRO max)	2	2	2
Nonrepeatability (° max)	0.002	0.002	0.002
Transverse Axis Misalignment (° max)	±1	±1	±1
Relative Accuracy (° max)	0.10	0.16	0.30
Bandwidth (Hz nom) (-3 dB)	<1	<1	<1
Start Up Time (Seconds max)	5	5	5
Response Time (Seconds max)	0.3	0.3	0.3

Electrical & Environmental	
Number of Axes	1 or 2
Input Voltage Range (Vdc max)	9 - 30
Input Current (mA @ 24V max)	15
Output Noise (Vrms max)	0.006
Output Impedance (Ohms nom)	10
Operating Temperature Range (°C)	-40 to +85
Storage Temperature Range (°C)	-50 to +105
Shock (g, 1 msec, ½-sine)	500
Weight (grams)	210 (7.4 oz.)
Seal	IP67
Cable	2 M (6.6 ft), flying leads

<sup>1</sup>Custom ranges available on request product development  
 \*Specifications subject to change without notice on account of continued  
 \*Measurements are performed at room ambient temperature unless stated otherwise



**ORDERING CODE**

A875 SERIES

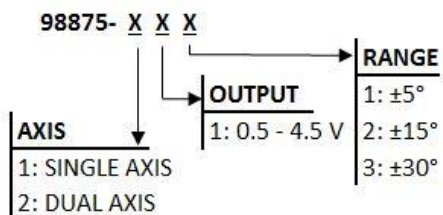

**Wiring:**

Wire Color	Function
Red	+Power
Black	Ground
Yellow	No Connection
Blue	No Connection
Green	Zero Cal.
White	X-Out
Brown	Y-Out
Grey	No Connection

- Output is linear with change in degrees tilt.
- **Zero Function:** Short green and black wires at power-on for 3 seconds and release.
- Do not short wires in operation mode.

**DIMENSIONS (mm)**

**Model A875 Mini "Tuff Tilt" Dimensions**

Units: Inch [MM]

Cable Length: 6.6 ft [2 M]

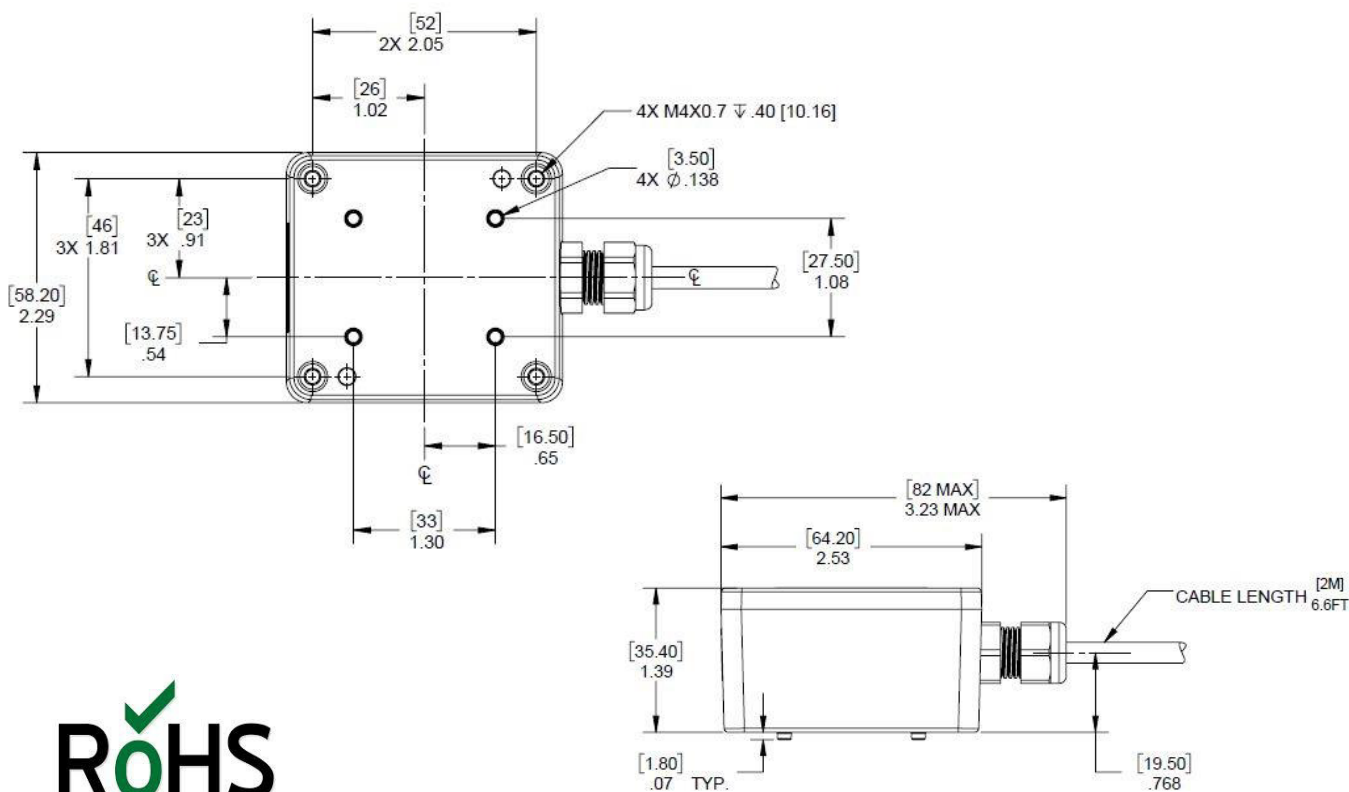



**STRAIGHT MOUNTING BRACKET**

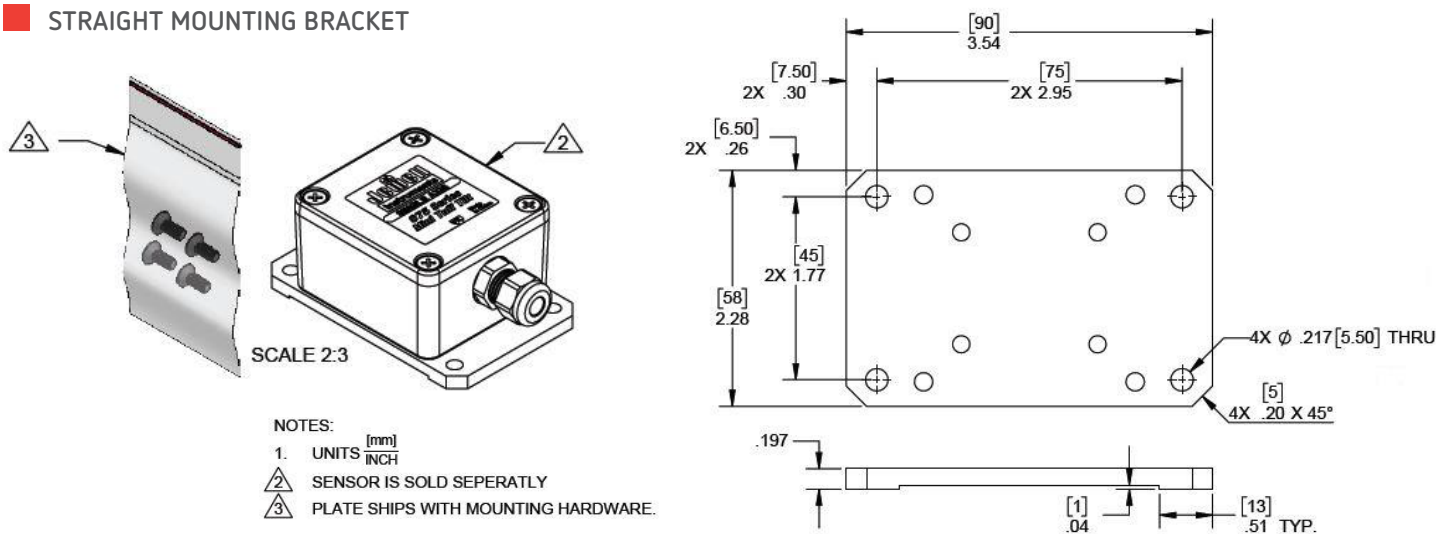

**RIGHT ANGLE MOUNTING BRACKET**

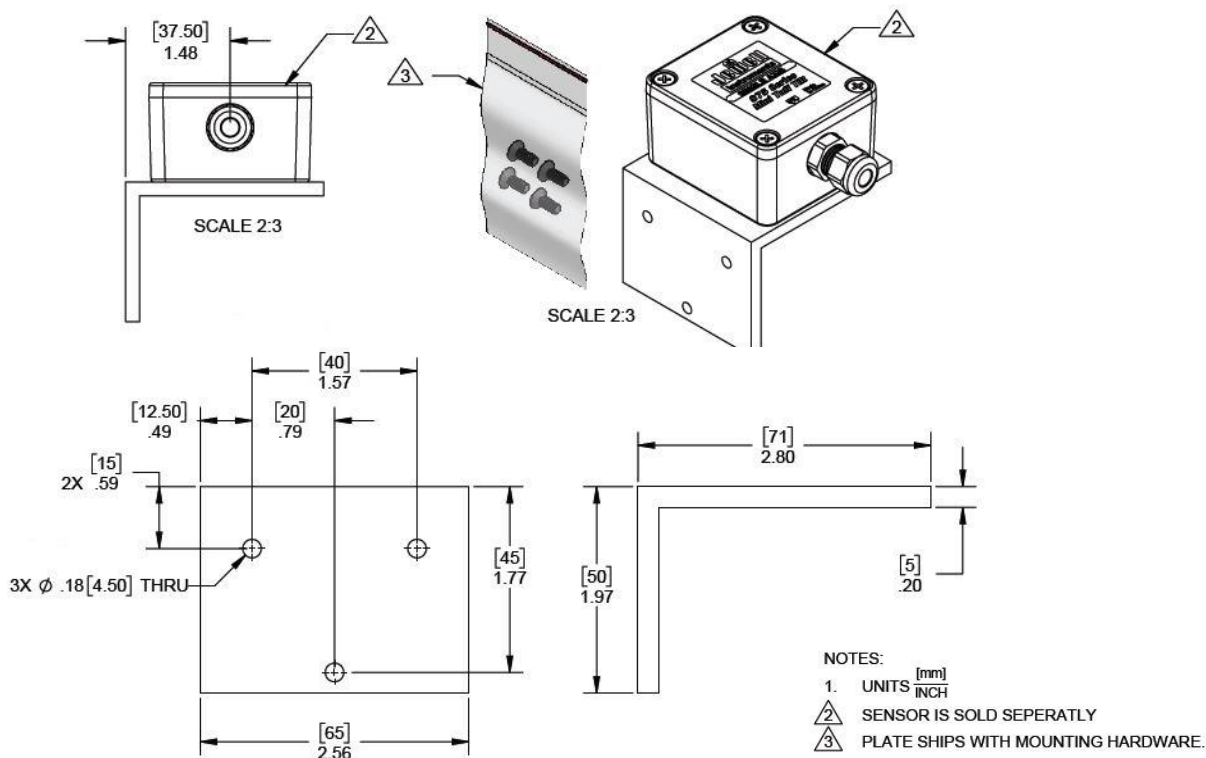

**HOW TO ORDER:**

Model	Part Number	Description
875-SMB	879851-01	Straight Bracket
875-RAMB	879851-01	Right Angle Bracket