



ASC 281 | ASC 283 Tactical Grade Gyroscopes



SPECIFICATIONS

- Uniaxial, Triaxial
- MEMS Vibrating Ring
- Measurement Range: ± 10 to ± 400 °/s
- Bias Stability: 0.03 to 0.10 °/hr
- Angular Random Walk: 0.005 to 0.010 °/√hr
- Aluminum Housing
- Made in Germany



TACTICAL GRADE GYROSCOPES

The key components in tactical grade gyroscopes are high-quality micro-electromechanical systems (MEMS) that feature excellent long-term stability and reliability. The design of the micro-mechanical silicon structures makes the gyroscopes extremely insensitive to external impacts and vibrations. They are therefore ideal suited for use in harsh environmental conditions. Due to their very high performance, the gyroscopes fulfill the requirements of tactical grade applications with respect to the maximum achievable precision, which otherwise can be achieved only with fiber optic gyroscopes (FOG).

DESCRIPTION

The gyroscopes of types ASC 281 and ASC 283 are based on proven MEMS vibrating ring sensor elements. The integrated electronic circuitry enables a very low noise quasidifferential analog voltage output (± 2.0 V FSO) and flexible power supply voltage from 8 to 30 VDC. The tactical grade gyroscopes are available in different measurement ranges (10 °/s to 400 °/s) and providing an outstanding bias stability of < 0.1 °/hr and an excellent angular random walk of < 0.01 °/√hr. The uniaxial gyroscopes ASC 281 and triaxial gyroscopes ASC 283 feature a lightweight, reliable aluminum housing with protection class IP65 and a detachable cable with configurable length and connectors. The excellent bias stability of these gyroscopes allows their use in applications such as gyro compassing, attitude heading reference systems AHRS or for orientation of underwater ROVs (remotely operated vehicles). Furthermore, as component of inertial systems the gyroscopes enable high-precision position measurements and bridging navigation in numerous areas of application, such as automated guided vehicles, ship guidance and control, robots, rail vehicles or aircraft systems.

FEATURES

- Tactical Grade Gyroscope, FOG-like Performance
- Very Low Noise Differential Voltage Output
- Outstanding Bias Stability and Angular Random Walk
- High Shock and Vibration Resistance
- Temperature Output

OPTIONS

- Customised Cable Length
- Customised Connector

APPLICATIONS

- Gyro-Compassing, Ship Guidance and Control
- AHRS, Flight Instruments
- Mid-term Bridging Navigation

ASC 281
(UNIAXIAL)

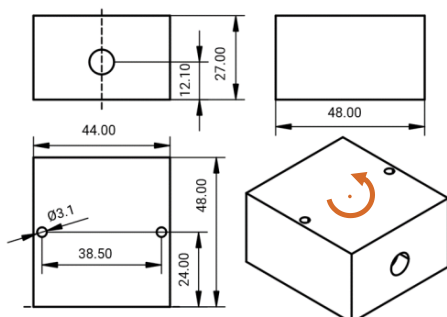

ASC 283
(TRIAxIAL)

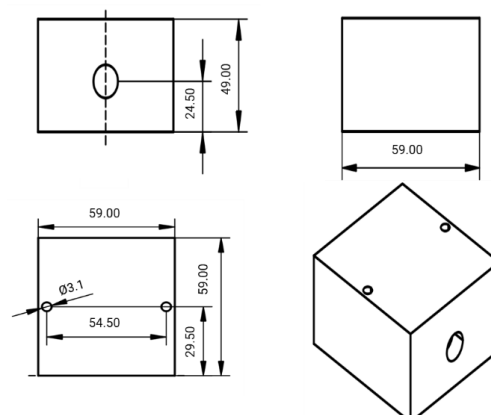



TYPICAL SPECIFICATIONS

Dynamic

Measurement Range	°/s	±10	±25	±100	±200	±400
Scale Factor (sensitivity)	mV/°/s	200	80	20	10	5
Rate Noise Density	°/s/√Hz	0.007	0.007	0.012	0.012	0.012
Bandwidth	Hz	50	50	100	100	100
Amplitude Non-Linearity	% FSO	0.02 (typ) 0.05 (max)				
Bias Stability	°/hr	0.03	0.04	0.04	0.05	0.10
Angular Random Walk	°/√hr	0.005	0.006	0.006	0.008	0.010

Electrical

Power Supply Voltage	V	8 to 30				
Operating Current Consumption	mA	ASC 281: <40 ASC 283: <120				
Offset (bias) referred to Reference Output Voltage	mV	±10				
Isolation		Case Isolated				

Environmental

Scale Factor Error over Temperature Range	%	±0.15 (typ) ±0.50 (max)		±0.30 (typ) ±0.50 (max)		
Offset (bias) Error over Temperature Range	°/s	±0.10 (typ) ±0.20 (max)		±0.15 (typ) ±0.25 (max)		
Operating Temperature Range	°C	-40 to +85				
Storage Temperature Range	°C	-40 to +100				
Shock Limit (0.1 ms, half -sine)	g	1000				
Vibration induced Noise	°/s/g ²	0.01				
Vibration Rectification Error	°/s/g ²	0.002				
g-Sensitivity	°/s/g	0.02				
Protection Class		IP65				

Physical

Sensing Element	MEMS Vibrating Ring					
Case Material	Anodized Aluminum					
Connector Sensor Housing	ASC 281: 7-pin Comtronic (male) ASC 283: 12-pin Comtronic (male)					
Connector at Cable End	Optional					
Mounting	Adhesive / Screw Holes					
Weight (without cable)	gram	ASC 281: 80 ASC 283: 250				
Cable for uniaxial ASC 281	13 gram per meter AWG 30 Polyurethane (PUR) Diameter 3.0 mm					
Cable for triaxial ASC 283	19 gram per meter AWG 30 Polyurethane (PUR) Diameter 4.5 mm					



ASC 281: SENSOR CALIBRATION

Factory Calibration (supplied with the sensor)

Part Number							
Measurement Range (sensor)	°/s	10	25	100	200	400	
Applied Frequency (min)	Hz	1	1	1	1	1	
Applied Frequency (max)	Hz	50	50	100	100	100	
Input Amplitude	°/s	5	12.5	50	100	200	
Reference Frequency for Determination of Scale Factor	Hz	16	16	16	16	16	

Calibration according DIN ISO 17025 (order separately)

Part Number							
Measurement Range (sensor)	°/s	10	25	100	200	400	
Applied Frequency (min)	Hz	1	1	1	1	1	
Applied Frequency (max)	Hz	50	50	100	100	100	
Input Amplitude	°/s	5	12.5	50	100	200	
Reference Frequency for Determination of Scale Factor	Hz	16	16	16	16	16	

Please note: If any other calibration procedure is required, don't hesitate to contact us. Furthermore, sensors have to be calibrated regularly to ensure accurate and precise results. Our services include both factory calibration and calibration in accordance with

ASC 283: SENSOR CALIBRATION

Factory Calibration (supplied with the sensor)

Part Number				#16152	#16153		
Measurement Range (sensor)	°/s	10	25	100	200	400	
Applied Frequency (min)	Hz	1	1	1	1	1	
Applied Frequency (max)	Hz	50	50	100	100	100	
Input Amplitude	°/s	5	12.5	50	100	200	
Reference Frequency for Determination of Scale Factor	Hz	16	16	16	16	16	

Calibration according DIN ISO 17025 (order separately)

Part Number							
Measurement Range (sensor)	°/s	10	25	100	200	400	
Applied Frequency (min)	Hz	1	1	1	1	1	
Applied Frequency (max)	Hz	50	50	100	100	100	
Input Amplitude	°/s	5	12.5	50	100	200	
Reference Frequency for Determination of Scale Factor	Hz	16	16	16	16	16	

TYPICAL SPECIFICATIONS

ASC 281: Cable Code / Pin Configuration

7-Pin Sensor Connector (male)		Color Code ASC AK -281	Description
2	Supply +	Red	Power: supply voltage +8 to +30 VDC
1	Supply -	Black	Power: GND
3	Signal +	Green	Positive, analog output voltage signal (+0.4 V to +4.4 V)
4	Ref. Signal	White	Reference analog output voltage signal for quasi -differential mode (+2.4 V)
5	Temp	Yellow	Analog output voltage temperature sensor (measured with respect to Ref. Signal)
6	nc	---	Not connected
7	nc	---	Not connected

ASC 283: Cable Code / Pin Configuration including common Power Supply for all Axes

12 -Pin Sensor Connector (male)		Color Code ASC AK -283	Description
2	Supply +	Red	Power: supply voltage +8 to +30 VDC
1	Supply -	Black	Power: GND
11	Signal +	Green	Z - Axis: positive, analog output voltage signal (+0.4 V to +4.4 V)
12	Ref. Signal	White	Z - Axis: reference analog output voltage signal for quasi-differential mode (+2.4 V)
5	Temp	Black/Violet	Z - Axis: analog output voltage temperature sensor
8	Signal +	Green/Grey	Y - Axis: positive, analog output voltage signal (+0.4 V to +4.4 V)
10	Ref. Signal	White/Grey	Y - Axis: reference analog output voltage signal for quasi -differential mode (+2.4 V)
4	Temp	Red/Grey	Y - Axis: analog output voltage temperature sensor
6	Signal +	Green/Violet	X - Axis: positive, analog output voltage signal (+0.4 V to +4.4 V)
7	Ref. Signal	White/Violet	X - Axis: reference analog output voltage signal for quasi -differential mode (+2.4 V)
3	Temp	Red/Violet	X - Axis: analog output voltage temperature sensor
9	nc	---	---

ASC 283: Cable Configuration for detachable Connector Cable (see accessories)

11 Wire System - 11L (Triaxial)

Common power supply for all axes, no cable switch



11 Wire System - 11 L3 (Triaxial)

Common power supply for all axes, including cable switch

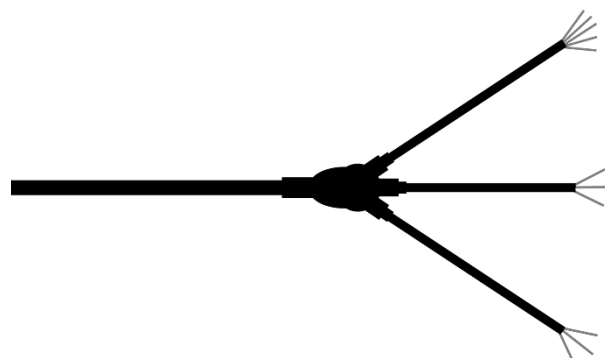



ORDERING INFORMATION

Ordering information are based on standard configurations. All types of the tactical grade gyroscopes ASC 281 and ASC 283 are fabricated for operating with a detachable cable including configurable length and connectors at the cable end. For the connection of the sensor housing, the single-axis ASC 281 uses a 7-pin Comtronic connector (female), the three-axis ASC 283 uses a 12-pin Comtronic connector (female). Connectors are already assembled, when ordered. All customized versions regarding connector and/or pinout will lead to a change or extension of the corresponding product match code.

Series	Model	-	Range [g]
ASC 28	1 (uniaxial)		010
	3 (triaxial)		025
			100
			200
			400

Example:

ASC 281-010

Accessories Connector Cable for ASC 281 (Uniaxial)

Cable	-	ASC Sensor	Wires	/	Cable Length [m]	/	Connector & Pinout
ASC AK		281	05		6		Open

Example:

ASC AK-281 05/06/open

Please note: Ordering information are based on standard configurations. All customized versions regarding connector and/or pinout will lead to a corresponding product match code.

Accessories Connector Cable for ASC 283 (Triaxial)

Cable	-	ASC Sensor	Wires	/	Cable Length [m]	/	Connector & Pinout	-	Cable Configuration
ASC AK		283	12		6		Open		11L
									11L3

Example:

ASC AK-283 12/06/open-11L

Please note: Ordering information are based on standard configurations. All customized versions regarding connector and/or pinout will lead to a corresponding product match code.

Standard length of the integrated cable is 6 meters. However, different customized cable lengths are possible on request. Standard version has no connector at the cable end which is identified by " open " in the product match code. However, it is possible to assemble almost all connector types during production. Different cable configurations are only available for the triaxial gyroscope ASC 283.



■ SAFETY PRECAUTION FOR INSTALLING AND OPERATING

This data sheet is a part of the product. Read the data sheet carefully before using the product and keep it available for future operation. Handling, electrical connections, mounting or any other work performed at the sensor must be carried out by authorized experts only. Appropriate safety precautions must be taken to exclude any risk of personal injury and damage to operating equipment as a result of a sensor malfunction.

Handling

The sensor is packaged in a reliable housing to protect the sensing elements and integrated electronic components from the ambient environment. However, poor handling of the product can lead to damages that may not be visible and cause electrical failure or reliability issues. Handle the component with caution:

- Avoid shocks and impacts on the housing, such as dropping the sensor on hard surface
- Never move the sensor by pulling the cable
- Make sure that the sensor is used within the specified environmental conditions
- Transport and store the sensor in its original or similar packaging
- The sensor should be mounted on a stable flat surface with all screws tightened or other mounting options
- Avoid any deformation during mounting the sensor
- Mounting tolerances may have an influence on the measured result

Electrical

ASC's inertial sensors are working with many established data acquisition systems. However, make sure that a proper DAQ is used, for the corresponding operation principle of the sensor. Furthermore, suitable precautions shall be employed during all phases of shipment, handling and operating:

- Active sensor pins are susceptible to damage due to electrostatic discharge (ESD)
- Make sure that the sensor is used within the specified electrical conditions
- Check all electrical connections prior to initial setup of the sensor
- Completely shield the sensor and connecting cable
- Do not perform any electrical modifications at the sensor
- Do not perform any adaptations on the wiring or connectors while the device under power
- Never plug or unplug the electrical connection while the sensor is under power
- When a certain pin is not used during operation, make sure that the pin is insulated

Quality

- We have a quality management system according to ISO 9001:2015.
- The Deutsche Akkreditierungsstelle GmbH (DAkkS) has awarded to our calibration laboratory the DIN EN ISO/17025:2018 accreditation for calibrations and has confirmed our competence to perform calibrations in the field of mechanical acceleration measurements. The pictured DAkkS-ILAC logo refers exclusively to the accredited service.
- All ASC products are -compliant.

