

ASC DiSens® 271
Industrial Grade Gyroscopes – Digital Interface



SPECIFICATIONS

- Uniaxial
- MEMS Vibrating Ring
- Measurement Range: Configurable ± 75 to ± 900 °/s
- Bias Stability: 12 °/hr
- Angular Random Walk: 0.2 °/ $\sqrt{\text{hr}}$
- Aluminum Housing
- Made in Germany



INDUSTRIAL GRADE GYROSCOPES

The key components in industrial grade gyroscopes are high-quality micro-electromechanical systems (MEMS) that feature excellent long-term stability and reliability. The design of the micro-mechanical silicon structures makes the gyroscopes extremely insensitive to external impacts and vibrations. They are therefore ideal suited for use in harsh environmental conditions. Due to their high performance, the gyroscopes fulfill the requirements of industrial grade applications with respect to the maximum achievable precision.

DESCRIPTION

The gyroscopes of type ASC DiSens® 271 are based on proven MEMS vibrating ring sensor elements. The integrated electronic circuitry enables digitization of measurement data and operation via a standard SPI interface as well as flexible power supply voltage from 5 to 40 VDC. The industrial grade gyroscopes are available in four measurement ranges (75 °/s to 900 °/s) which are selectable even in operation by corresponding ASIC registers and providing a bias stability of 12 °/hr and an angular random walk of 0.2 °/ $\sqrt{\text{hr}}$.

The uniaxial gyroscopes ASC DiSens® 271 feature a lightweight, reliable aluminum housing with protection class IP65 and an integrated cable with configurable length and connectors.

Ideal applications are dynamic roll, pitch and yaw angle measurements in motor vehicles, ships and aircraft, as well as monitoring of vehicle dynamics in AGVs (automated guided vehicles) or the orientation of UAVs (unmanned aerial vehicles) in smart agriculture.

FEATURES

- Industrial Grade Gyroscope
- Standardized SPI Interface
- Measurement Range Selection during Operation
- Self-Test Option
- Temperature Output

OPTIONS

- Customised Cable Length
- Customised Connector

APPLICATIONS

- Vehicle Dynamics of AGV/UAV
- Track Geometry in Rail Transport Applications
- Camera, Antenna and Platform Stabilization Systems

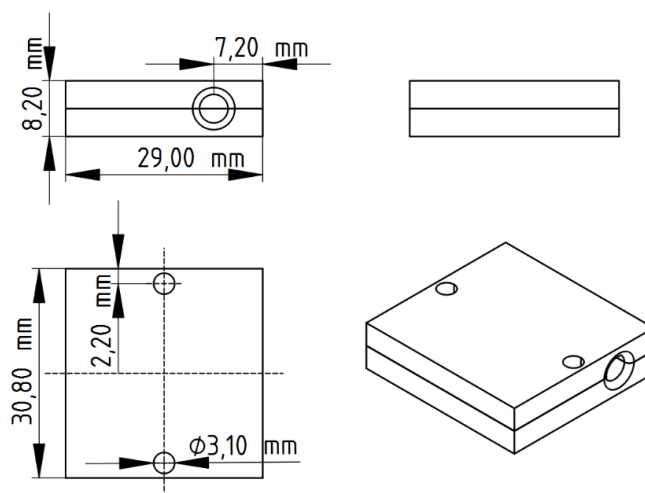



TYPICAL SPECIFICATIONS

Dynamic

Selectable Measurement Range	°/s	±75	±150	±300	±900
Scale Factor (sensitivity)	LSB /°/s	96	48	24	8
Scale Factor Variation	%	0.5 (typ) 1.5 (max)			
Offset (bias)	LSB	±48			
Rate Noise Density	°/s/√Hz	0.018 (typ) 0.025 (max)			
Bandwidth (±3 dB)	Hz	150			
Amplitude Non-Linearity	% FSO	<0.06 (typ) <0.15 (max)			
Bias Stability	°/hr	12			
Angular Random Walk	°/√hr	0.2			

Electrical

Power Supply Voltage	V	5 to 40			
Operating Current Consumption	mA	6 (13 during start - up)			
Isolation		Case Isolated			

Environmental

Scale Factor Error over Temperature Range	%	±0.5 (typ ±1.5 (max)			
Offset (bias) Error over Temperature Range	°/s	±1.0 (typ ±3.0 (max)			
Operating Temperature Range	°C	-40 to +85			
Storage Temperature Range	°C	-40 to +100			
Shock Limit (operating, 1 ms)	g	500			
Shock Limit (survival, 0.1 ms)	g	10000			
Vibration induced Noise	°/s/g ²	0.060 (typ) 0.072 (max)			
Vibration Rectification Error	°/s/g ²	0.001 (typ) 0.003 (max)			
g-Sensitivity	°/s/g	0.080 (typ) 0.200 (max)			
Protection Class		IP 65			

Physical

Sensing Element	MEMS Vibrating Ring				
Case Material	Anodized Aluminum				
Connector at Cable End	Optional				
Mounting	Adhesive Screw Holes				
Weight (without cable)	gram	15			
Cable	30 gram per meter AWG 30 Polyurethane (PUR) Diameter 4.5 mm				



■ CABLE CODE / PIN CONFIGURATION (6 WIRE SYSTEM)

	Pin	Color Code	Description
1	Supply +	Red	Power supply voltage +5 to +40 VDC
2	Supply -	Black	Power GND
3	CLK	Red / Grey	Serial Clock
4	MOSI	Green / Grey	Master Output, Slave Input
5	MISO	White / Grey	Master Input, Slave Output
6	CS	Black / Grey	Chip Select

■ ORDERING INFORMATION

Series	Model	- Cable Length [m]	Connector & Pinout
ASC DiSens®	271	6	A

Example:

ASC DiSens® 271 - 6A

Ordering information are based on standard configurations. All customized versions regarding connector and/or pinout will lead to a corresponding product match code:

- The ASC DiSens® 271 is based on a digital SPI interface. A detailed description is figured out in a separate manual.
- Standard length of the integrated cable is 6 meter s. However, different customized cable lengths are possible on request.
- Standard version has no connector at the cable end which is identified by "A" in the product match code. However, it is possible to assemble almost all connector types during production.
- When a calibration procedure is required, don't hesitate to contact us. Our services include both factory calibration and calibration in accordance with DAkkS guidelines.



■ SAFETY PRECAUTION FOR INSTALLING AND OPERATING

INDUSTRIAL GRADE GYROSCOPES

This data sheet is a part of the product. Read the data sheet carefully before using the product and keep it available for future operation. Handling, electrical connections, mounting or any other work performed at the sensor must be carried out by authorized experts only. Appropriate safety precautions must be taken to exclude any risk of personal injury and damage to operating equipment as a result of a sensor malfunction.

HANDLING

The sensor is packaged in a reliable housing to protect the sensing elements and integrated electronic components from the ambient environment. However, poor handling of the product can lead to damages that may not be visible and cause electrical failure or reliability issues. Handle the component with caution:

- Avoid shocks and impacts on the housing, such as dropping the sensor on hard surface
- Never move the sensor by pulling the cable
- Make sure that the sensor is used within the specified environmental conditions
- Transport and store the sensor in its original or similar packaging
- The sensor should be mounted on a stable flat surface with all screws tightened or other mounting options
- Avoid any deformation during mounting the sensor
- Mounting tolerances may have an influence on the measured result

ELECTRICAL

The inertial sensors are working with many established data acquisition systems. However, make sure that a proper DAQ is used, for the corresponding operation principle of the sensor. Furthermore, suitable precautions shall be employed during all phases of shipment, handling and operating:

- Active sensor pins are susceptible to damage due to electrostatic discharge (ESD)
- Make sure that the sensor is used within the specified electrical conditions
- Check all electrical connections prior to initial setup of the sensor
- Completely shield the sensor and connecting cable
- Do not perform any electrical modifications at the sensor
- Do not perform any adaptations on the wiring or connectors while the device under power
- Never plug or unplug the electrical connection while the sensor is under power
- When a certain pin is not used during operation, make sure that the pin is insulated

QUALITY

- We have a quality management system according to ISO 9001:2015.
- The Deutsche Akkreditierungsstelle GmbH (DAkKS) has awarded to our calibration laboratory the DIN EN ISO/IEC 17025:2018 accreditation for calibrations and has confirmed our competence to perform calibrations in the field of mechanical acceleration measurements. The registration number of the certificate is D-K-18110-01-00.
- All ASC products are CE-compliant.