

- ✓ Includes DI-2008 instrument, WinDaq software, calibration certificate, terminal screwdriver, and USB cable (6-feet)
- ✓ Eight differential and isolated analog input channels
- ✓ Seven bi-directional digital input ports, including:
 - ✓ Counter input for totalizing applications
 - ✓ Rate input for frequency/flow/rpm applications
- ✓ ChannelStretch™ channel expansion to 128 analog and 112 digital channels
- ✓ Programmable voltage and thermocouple measurements per channel
- ✓ 10 mV to 50 V programmable range per channel in 12 steps
- ✓ Programmable support for type J, K, T, B, R, S, E, N thermocouples per channel
- ✓ High resolution (16-bit) measurements
- ✓ 2000 Hz max sample throughput for a single channel and 200 Hz for two or more
- ✓ Minimum sample throughput rates as low as 1 sample per day
- ✓ USB interface
- ✓ Included WinDaq software for ready-to-run measurements
- ✓ Included .NET class for Visual Studio program development
- ✓ Fully documented device protocol supports other operating systems

DI-2008 Description

One PC-based product offers affordable and expandable measurement flexibility with analog isolation that's so critical for successful measurements in any situation: Model DI-2008. Read on and let us show you why this low-cost data acquisition system supplies the performance of products many times its price.

Analog Subsystem

Eight analog input channels adapt to a wide range of measurement types and applications. Each channel can be independently programmed for a thermocouple or voltage measurement. Programmed as a voltage channel you can select one of twelve measurement ranges from ± 10 mV to ± 50 V. A range of ± 5 V supports 4-20 mA measurements using typically a 250 Ω shunt resistor (model R250 sold separately). Programmed as a thermocouple channel you can select from eight thermocouple types: J, K, T, B, R, S, E, or N. Linearization and junction compensation are automatically applied by the DI-2008 for the selected TC type to deliver values scaled in either $^{\circ}\text{C}$ or $^{\circ}\text{F}$. Rounding out the DI-2008, a built-in 15 V sensor excitation power supply simplifies external wiring and further reduces overall system cost. Finally, all analog measurements benefit from a 16-bit ADC resolution to reveal even the smallest signal variations.

Virtually any measurement will experience a difference in ground potential between the instrument, the signal source, and even between signal sources. Known as common mode voltages, they cause noisy measurements in the best case or damage to the instrument in the worst case unless it's specifically designed to tolerate them like the DI-2008. Each DI-2008 analog input is electrically isolated from other channels and from ground for safe and accurate measurements in the presence of common mode voltages. Channel isolation means that each analog input is free to float to an independent common mode voltage imposed upon it by the signal source up to 120 V rms, and still provide an accurate and noise-free measurement.

Digital Port Subsystem

The DI-2008 provides 7 digital ports, each configurable as an input or a switch. Input protection is provided to 30 V. Configured as a switch a digital port can be used to control external loads up to 30 V @ 100 mA, and the switch can be controlled asynchronously without interrupting the scanning process. When activated as inputs two ports allow dual functionality to be used as discrete inputs, or one as a counter and the other a rate input. The rate input features a 50 kHz maximum measurement allocated over twelve programmable measurement ranges (10 Hz to 50 kHz full scale). The counter input provides 16-bit resolution and a terminal count value of 65,535. The discrete, counter, and rate inputs are members of the same internal scan list used by the analog input channels. This means that all enabled elements are acquired synchronously, which allows meaningful comparisons between analog and digital channels. For example, the rate input measuring engine speed allows rpm data to be acquired synchronously with analog data.

Supports ChannelStretch™ Channel Expansion

Simply add more DI-2008s to achieve synchronous channel expansion up to 128 analog channels and 112 digital ports (details inside).

DI-2008 Close-up

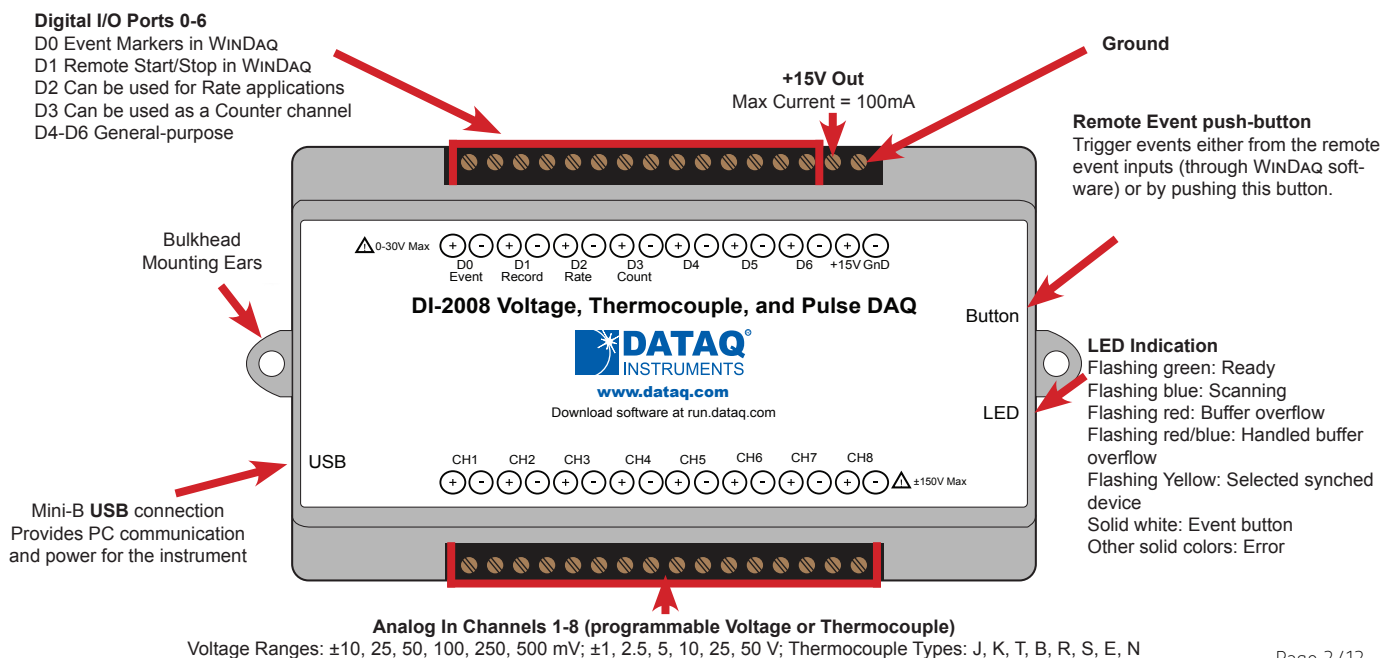

DI-2008 Major Features and Benefits

Eight Analog Input Channels

Measure as many as eight analog system variables at once with a single instrument.

Supports ChannelStretch™ Channel Expansion

Add more DI-2008s to provide synchronous channel expansion to 128 analog channels and 112 digital ports.

Differential Input configuration

Noise-cancelling measurements in virtually any application setting.

Programmable Voltage Ranges per Channel

Each DI-2008 channel may be programmed for one of the following ranges: ±10, 25, 50, 100, 200, 500 mV; ±1, 2.5, 5, 10, 25, 50 V

Programmable Thermocouple Types per Channel

The DI-2008 supports direct-connected J, K, T, B, R, S, E, and/or N thermocouples without external signal conditioning.

Wide Sampling Rate Range

Sample from minute to millisecond intervals using the supplied software. A single enabled channel can be sampled as fast as 2 kHz or as low as 1 sample every 2.5 hours.

Excitation Power Supply Output

Forget additional power supplies. Use the DI-2008's 15 V/60 mA excitation output to power external sensors, like voltage and 4-20 mA output sensors.

Rate Measurement Channel

Measure pulse rates from sensors for rpm or flow, for example. Twelve programmable ranges from 10 Hz to 50 kHz.

Counter Channel

Totalize the number of pulses applied. Useful for integrating rate information, like flow rate to volume, or simply the number of events.

16-bit Measurement Resolution

Resolve even the smallest changes in applied voltage and temperature (see specifications for details).

Isolated Analog Inputs

Allows no-consequence, off-ground measurements in demanding industrial settings.

Seven Digital Ports

Folds discrete I/O into the measurements process. Each bit is programmable as an input or as a switch.

Protected Inputs

Analog and digital inputs are protected to prevent mishap-causing damage to the instrument. Analog inputs to 120 V rms and digital to +30 V.

Built-in CJC

Cold junction compensation is automatically enabled for any channel programmed as a thermocouple input.

Included Ready-to-run Software

Our WinDaq data acquisition software offers real time display and disk streaming for the Windows environment up to the full sample rate of the DI-2008. The real time display can operate in a smooth scroll or triggered sweep mode of operation, and can be scaled into any unit of measure. Event markers with comments allow you to annotate your data acquisition session with descriptive information as you record to disk. Raise your productivity to new heights with WinDaq's unique multitasking feature. Record waveform data to disk in the background while running any combination of programs in the foreground — even WinDaq Playback software to review and analyze waveform data as it's being stored! Playback supports waveform analysis (Statistics, X-Y plots, frequency analysis) and the ability to export data to Microsoft Excel. WinDaq recording and playback software is provided free with every DI-2008 purchase. See the WinDaq Multimedia Tutorial for more information.

DI-2008 Dimensional Drawing

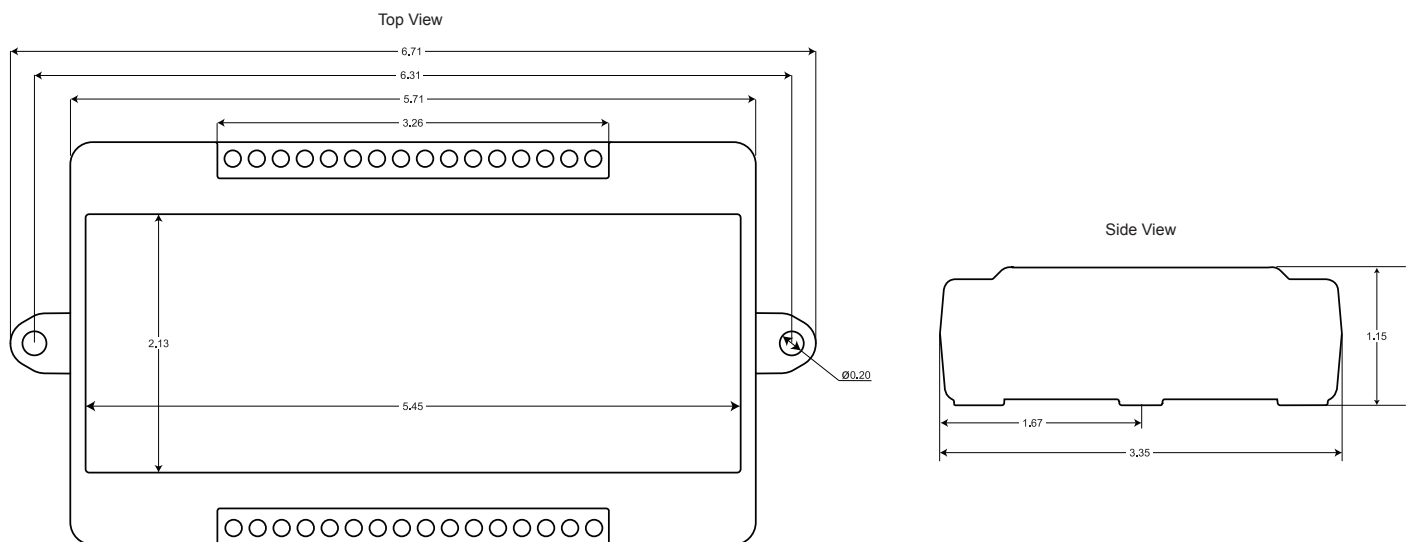

All dimensions in inches

Channel Expansion Using ChannelStretch™ Technology

Need more than eight analog channels or seven digital ports? Just add another DI-2008. In fact you can add as many as 15 additional units for a total of 128 analog channels and 112 digital ports. Multiple DI-2008s connected to the same USB hub automatically synchronize to within 10 μs between units, and the maximum sample rate throughput of each instrument is preserved. For example, twelve chained DI-2008 each with a single enabled channel supports 24 kHz throughput (12 × 2 kHz). If you need more USB ports to accommodate more DI-2008 units, simply cascade multiple hubs to expand USB port count. Best of all, when using WinDaq software the enabled channels of all synced units flow into the same WinDaq application. They're displayed and recorded together as though they were all acquired from a single instrument. See Detailed Specifications for supported channels and sample rate combinations. The WinDaq/Unlock option is required for a DI-2008 to use ChannelStretch™ when using our WinDaq software, but the ChannelStretch™ feature supports the instrument protocol and .Net class so you can fold this powerful feature into your own applications.

ChannelStretch™ Technology

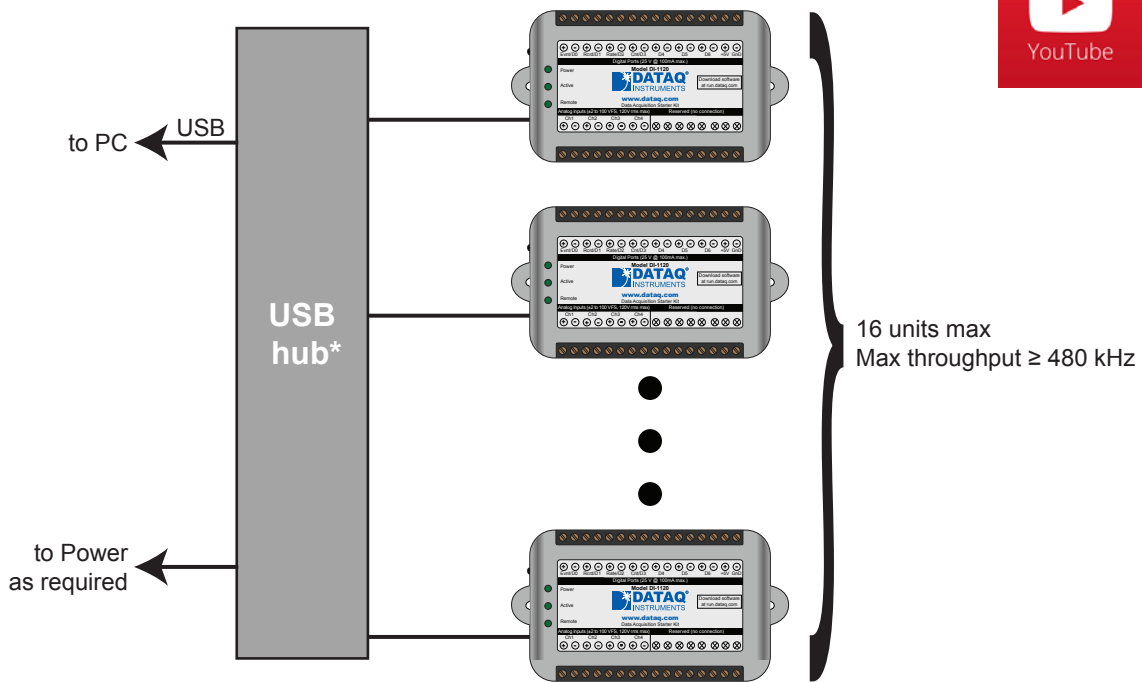

*DATAQ Instruments 7-port USB hub (part number 2000310). Cascade for a higher port count.

DI-2008 I/O Equivalent Circuits

Analog Input

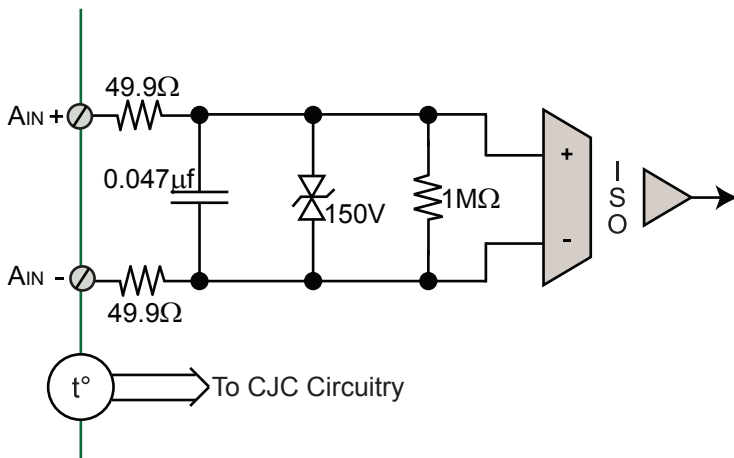

Digital Port

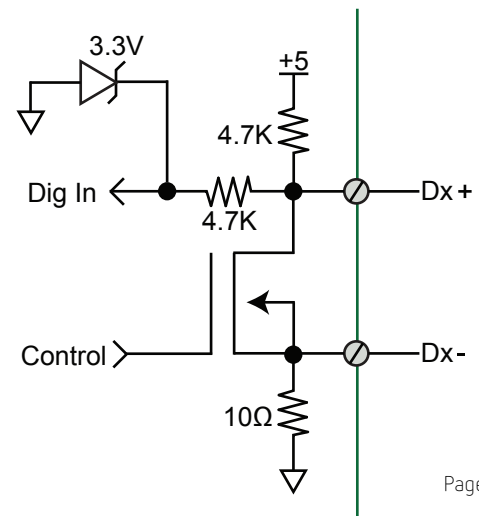

Typical Configurations and Applications

The DI-2008 can adapt to almost any industrial measurement. Typical uses are:

- Off-ground current shunts
- Large source voltages
- 4-20 mA process current (including self-powered)
- Thermocouple-based temperatures
- Totalizing applications (volume from flow, energy, etc.)
- Rate (rpm, flow, etc.)

The DI-2008's isolated analog inputs allow the instrument to tolerate measurement conditions that products many times its price range will not. This is important for measurement applications with inherent common mode voltages, like high-side current shunts in both 4-20 mA and general current measurements. Isolation also reduces ground loop and common mode voltage errors associated with long wiring runs, grounded thermocouples and other grounded measurement sources. In short, no other product in its price range provides more measurement flexibility and adaptability than the DI-2008.

General configuration

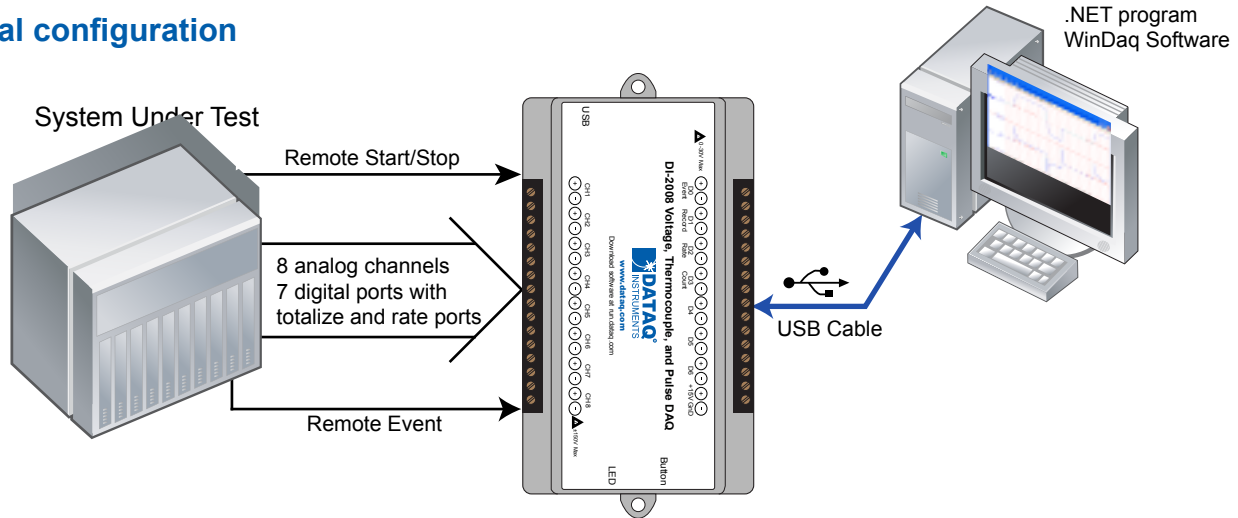

4-20 mA current (low-side shunt)

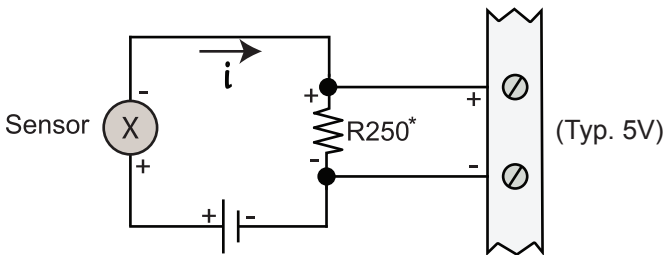

4-20 mA current (high-side shunt)

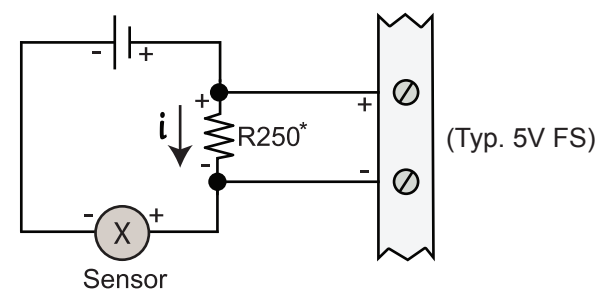

Grounded and Powered Thermocouple

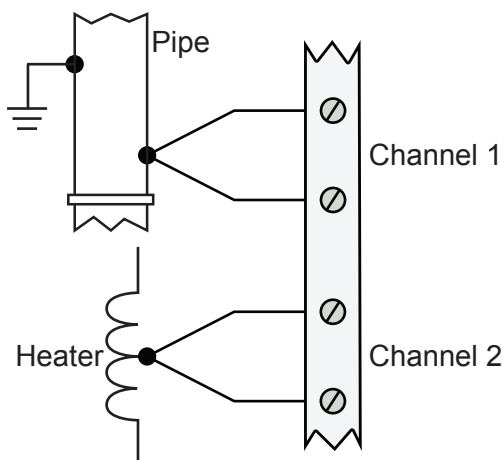

Simultaneous voltage and current

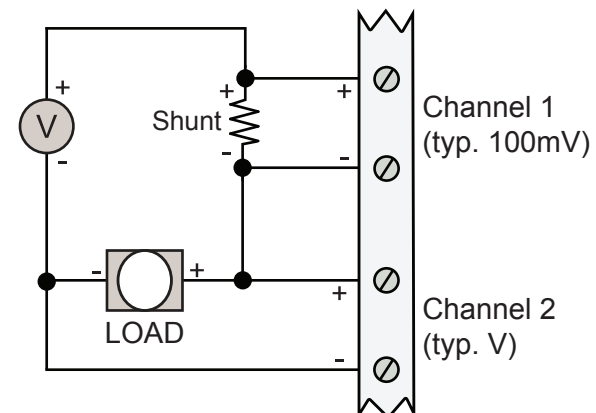

Typical Configurations and Applications (continued)

Self-powered 4-20 mA sensor

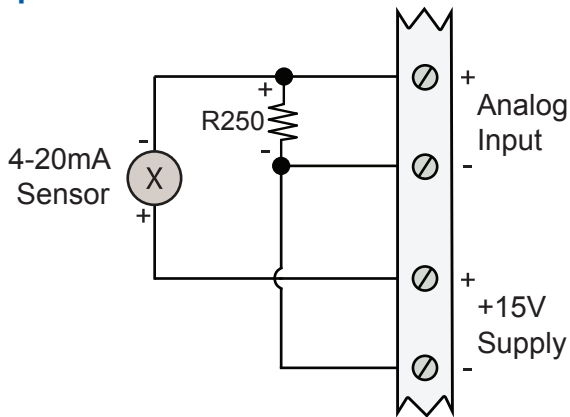

Two Self-powered 4-20 mA sensors

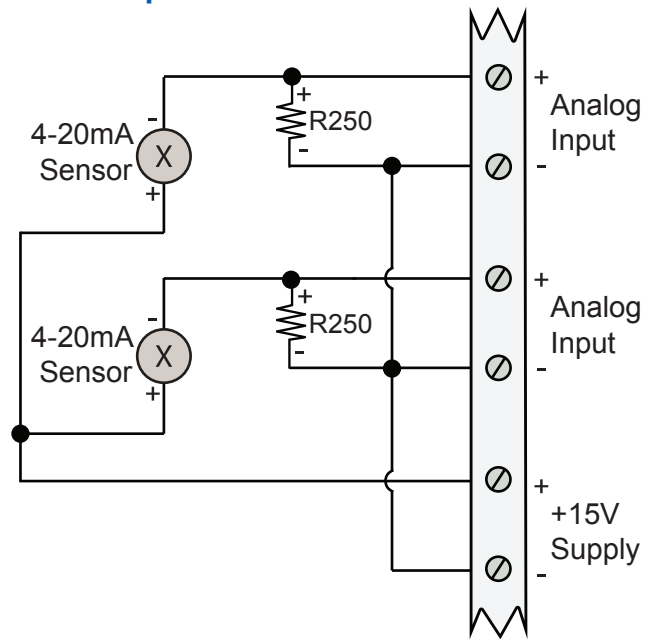

Stacked cells

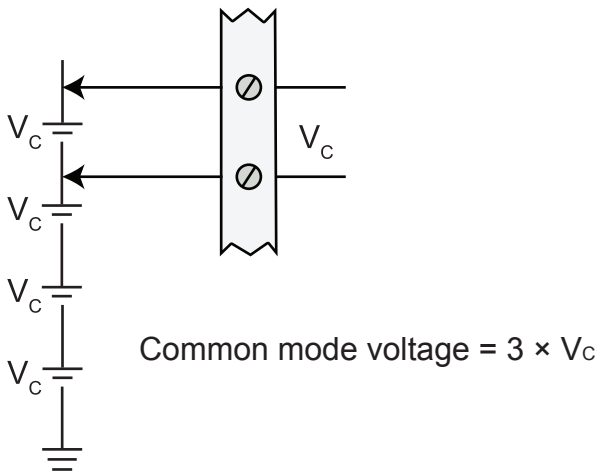

Heat flux sensor

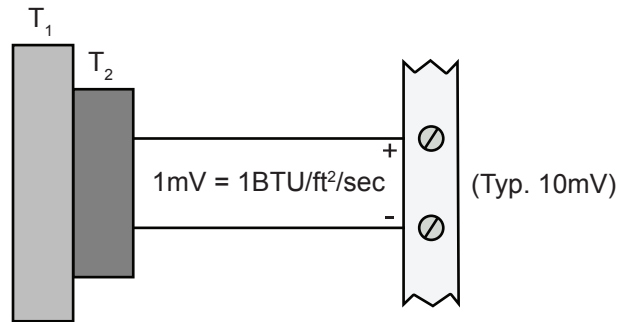

Totalizing (ex. volume from flow)



Rate measurement

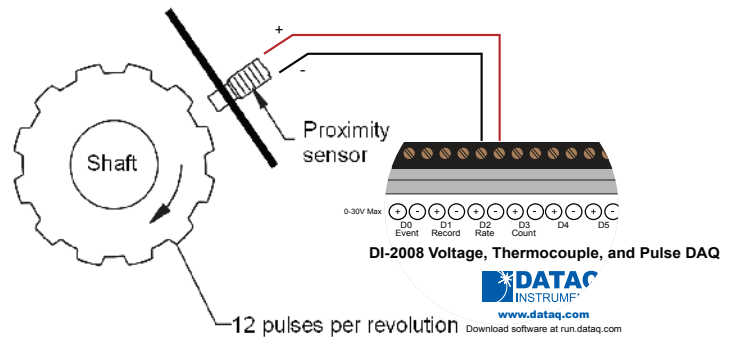

Typical Configurations and Applications (continued)

Photovoltaic Measurements

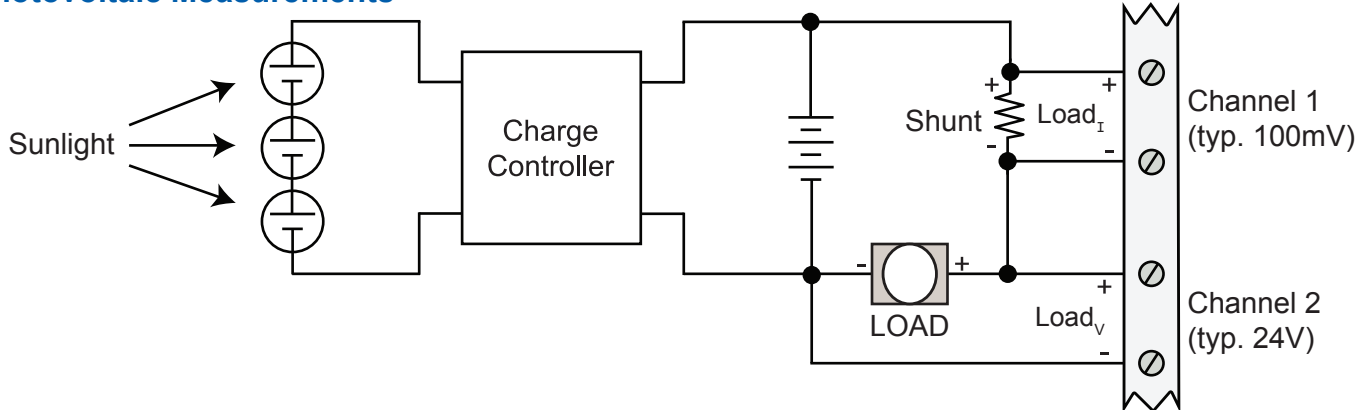

Operating Digital Ports as Switches

Each DI-2008 digital port can be configured as a digital input or used as a switch to control an external load. Ports are configured by a MOSFET that defines the port's function, where the MOSFET is either on or off. When the MOSFET is off the port is available as a discrete input. Turning the MOSFET on allows the port to function like a switch for loads up to 30 V and 100 mA with the following typical correct and incorrect connections:

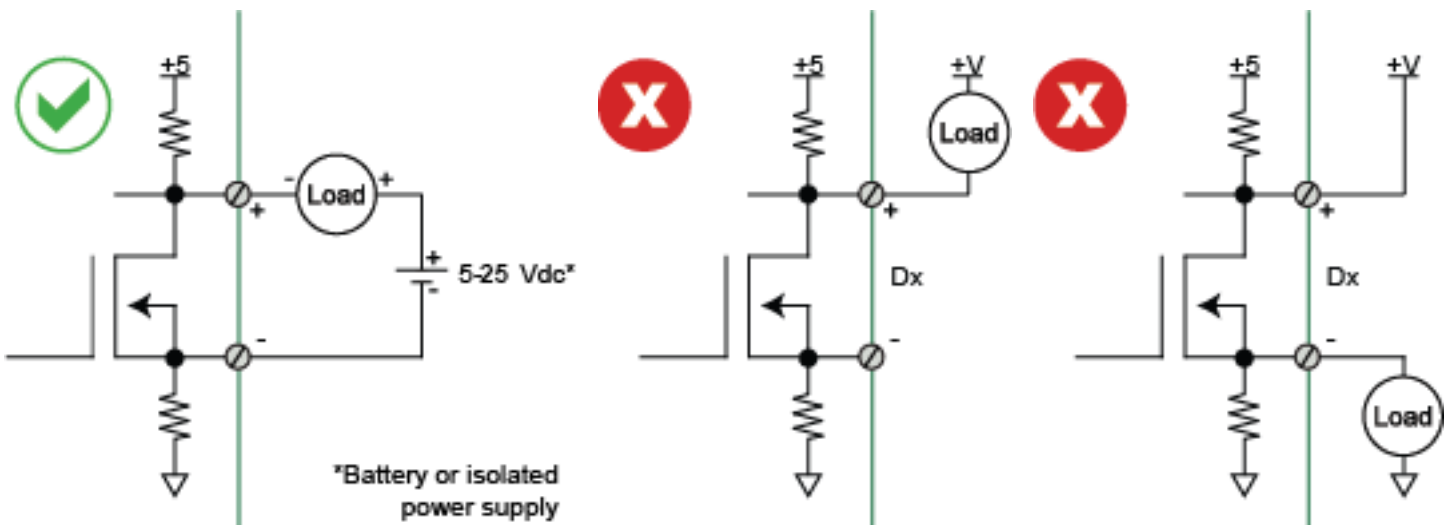

Included WINDAQ Recording Software (click on graphics for close-up views)

Setup

Double-click and enter the channels you want to acquire into the WinDAQ scan list. These can be channels from a single or multiple units using ChannelStretch™. Click to select a voltage, TC, rate, or count channel. Click to define a single to 32-channel display - either triggered sweep (oscilloscope-like) or scrolling (chart recorder-like). Click again to define a sample rate ranging from about 10 samples per day to 2,000 samples per second.

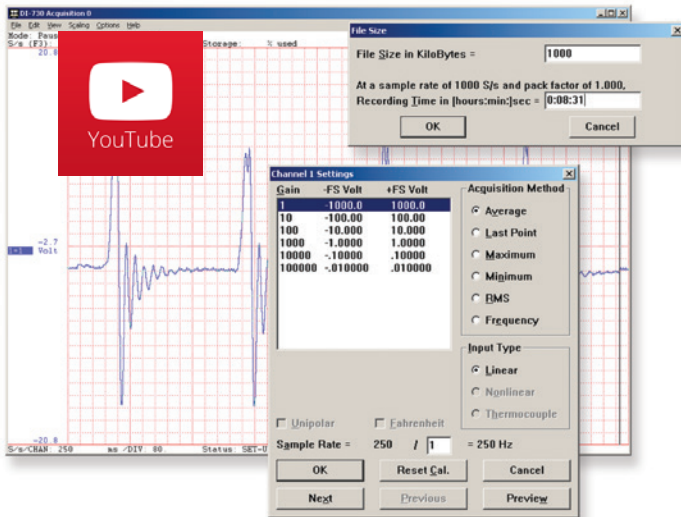

Scale

Define engineering units per channel to display waveform values in meaningful units such as psi, °F or °C, amps, rpm, watts, Horsepower— any unit of measure you need.

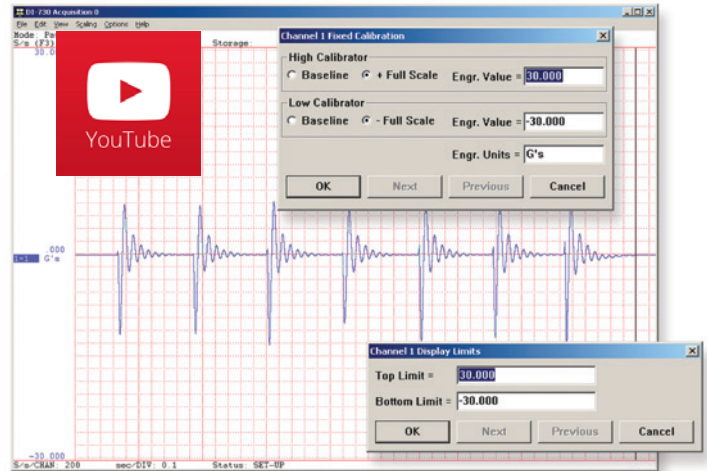

Record

Choose a continuous waveform recording mode or the triggered mode with selectable trigger level, slope, and post-trigger times. WINDAQ automatically time- and date-stamps, then streams acquired data to disk — record as much data as you need. At the same time, WINDAQ supplies a real-time graphical display of any or all channels so you always know where you are and where you're going.

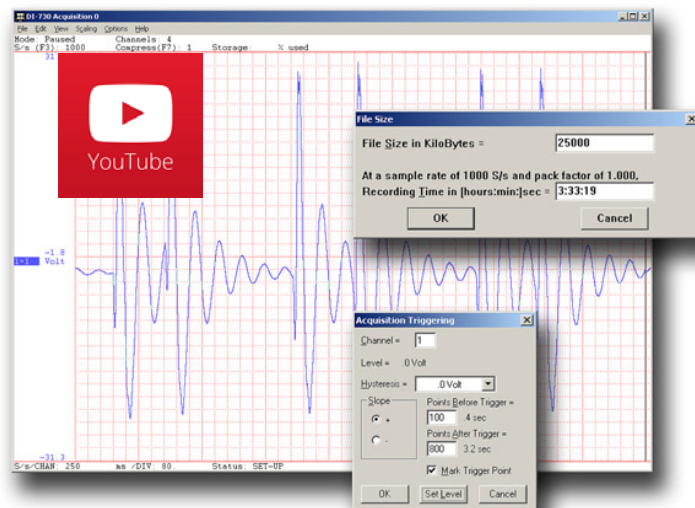

Annotate

Of course, you can label any channel with text that describes it — “Motor 1,” “Engine speed,” “Vertical position,” etc. But WINDAQ also allows you to supply commented event markers while you record — “Beginning test phase 1,” “Small vibrations noticed,” “Starting cool-down cycle,” etc. Your comments and our acquired data combine to form a complete diary of your data acquisition session.

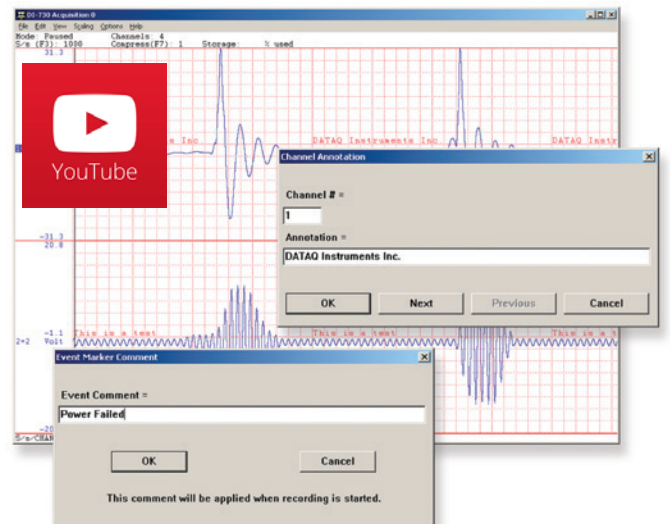

Included WINDAQ Playback Software

Playback

Recording is only half the solution. WINDAQ's Waveform Browser playback software allows you to graphically manipulate waveforms in ways you've never seen on a PC. Compress an entire recording to one screen-width for a bird's eye view, then expand around an area of interest for a closer look. Use the cursor to measure amplitudes and timing with precision. Move to any event marker with the click of a mouse button.



Multitask

Double your productivity and let WINDAQ record while you review last week's results from your spreadsheet, or compose a memo with your word processor. You can even play back data already stored to disk while you're still recording.

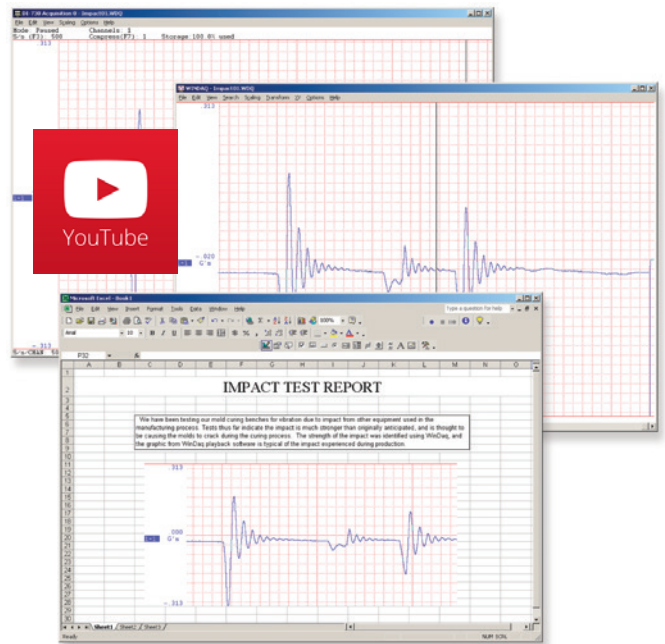

Analyze

Waveform interpretation is easy with our built-in analysis functions. Apply frequency and filtering analysis with the WINDAQ Waveform Browser FFT and DFT functions. Analyze any range of waveform data with the statistics function. Use X-Y plotting to examine the relationship of one channel to another. Optional Advanced CODAS analysis functions allow waveform peak detection, integration, differentiation, arithmetic operations, and more.

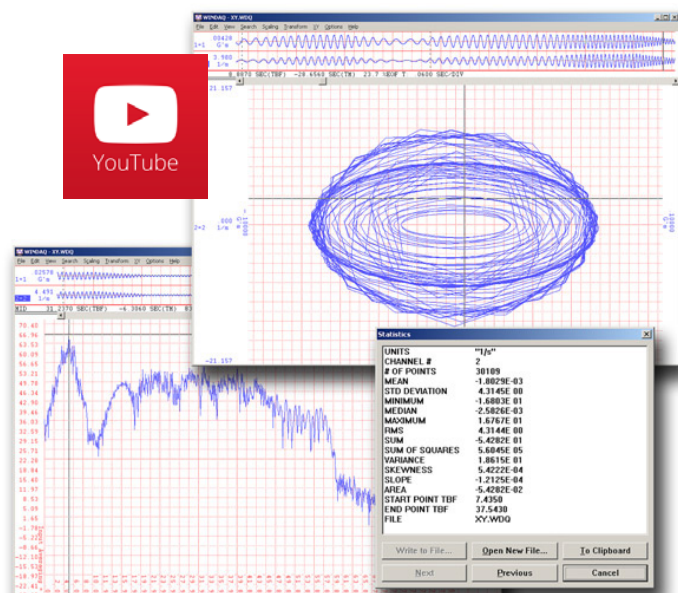

Export

The WINDAQ Waveform Browser can export any range of data to your spreadsheet, or any other analysis or presentation package you use. You can even copy a graphical image displayed by the WINDAQ Waveform Browser and paste it directly into a word processing document. Finally, export any range of waveform graphics to your printer for a hard copy record.

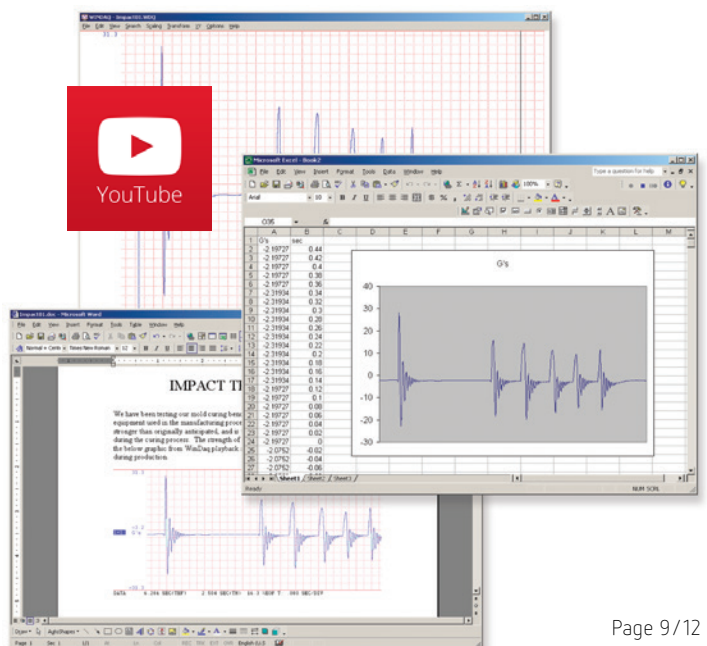

Published Protocol and .NET Class

For programmers, the DI-2008 is supported outside of the supplied ready-to-run WinDaq application by a published protocol and a .NET class. The protocol defines the nuts-and-bolts communication syntax to and from the instrument necessary to configure the DI-2008, allow it to take measurements, and to retrieve those measurements through a connected PC. You'd use the DI-2008 at its protocol level if you wanted to program the instrument outside the Windows environment and/or use a programming language that is not supported by .NET. For example, operating systems such as OSX and Linux, and programming languages such as Java and Python are candidate situations to use the DI-2008 Protocol. Otherwise, programming efforts using a .NET language such as Visual BASIC and C# under Windows take advantage of the .NET class provided with the instrument. Both the protocol and the .Net class support the DI-2008's ChannelStretch™ channel expansion feature to a maximum 128 analog and 112 analog ports.

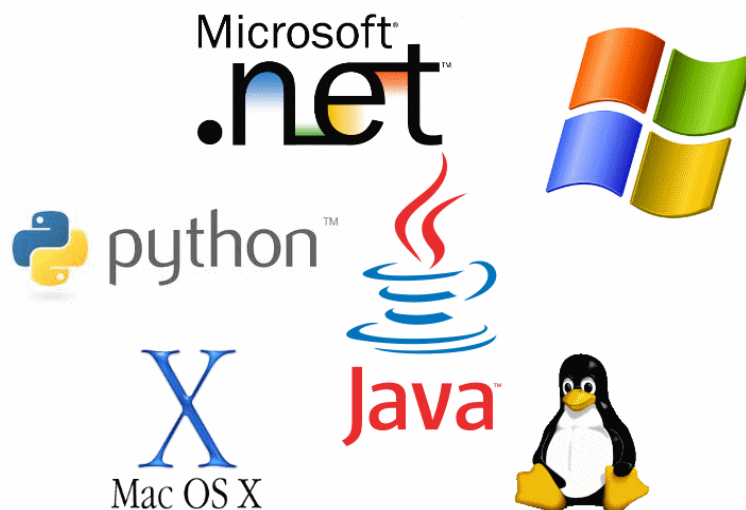

DI-2008 Specifications

Signal Inputs

Analog Inputs

Number of Channels: 8
 Configuration: Differential, Isolated
 Programmable measurements per channel: Voltage, thermocouple
 Programmable thermocouple types and measurement range per channel:

| TC type | Temperature Measurement range (°C) | Accuracy (°C) |
|---------|------------------------------------|---------------------|
| J | -190 to 1200 | ±(0.1% of span + 2) |
| K | -180 to 1360 | ±(0.1% of span + 2) |
| T | -190 to 400 | ±(0.1% of span + 1) |
| B | 600 to 1000 | ±(0.2% of span + 4) |
| | 1001 to 1810 | ±(0.1% of span + 3) |
| R | -40 to 300 | ±(0.2% of span + 6) |
| | 301 to 1760 | ±(0.1% of span + 3) |
| S | -40 to 400 | ±(0.2% of span + 6) |
| | 401 to 1750 | ±(0.1% of span + 3) |
| E | -160 to 990 | ±(0.1% of span + 1) |
| N | -170 to 50 | ±(0.1% of span + 3) |
| | 51 to 1290 | ±(0.1% of span + 1) |

Over 25 ±5 °C ambient temperature range.
 Stable ambient temperature.
 Following 30 minutes warm-up.
 Excluding common mode error.
 Excluding thermocouple error.

Programmable voltage measurements ranges per channel:

At 25 °C ambient temperature.
 Following 30 minutes warm-up.
 Excluding common mode error.

| Range (±) | Accuracy |
|-----------|---------------------------|
| 10 mV | ±(0.05% of range + 10 µV) |
| 25 mV | |
| 50 mV | |
| 100 mV | |
| 250 mV | |
| 500 mV | |
| 1 V | |
| 2.5 V | |
| 5 V | |
| 10 V | |
| 25 V | |
| 50 V | |

Input impedance: 1 MΩ, all ranges
 Isolation: Input-to-output, Channel-to-channel
 Absolute max input without damage: 120 Vrms
 Maximum common mode voltage: 120 Vrms
 Min common mode rejection (330Ω unbalance): >100 dB (DC to 60 Hz)
 Channel-to-channel crosstalk rejection: > 100 dB at any throughput
 ($R_{source} \leq 330 \Omega$; $Freq_{source} \leq 60 \text{ Hz}$)

Digital Ports

Number of ports: 7
 Type: MOSFET switch
 Configuration: Programmable as an input or switch
 Pull-up value: 4.7 KΩ
 Isolation: None
 Input high voltage threshold: 2.4 V minimum
 Input low voltage threshold: 0.8 V maximum
 Absolute max input without damage: $0 \leq V \leq 30 \text{ V}$

Count/Rate

Digital port assignment: Count: Port 2 configured as input
 Rate: Port 3 configured as input
 Internal pull-up value: 4.7 kΩ
 Input high voltage threshold: 2.4V
 Input low voltage threshold: 0.8V
 Terminal count: 65,535
 Maximum rate frequency: 50 kHz
 Minimum rate frequency: 0.5 Hz
 Maximum count frequency: 50 kHz

Power

Excitation output: +15 V dc (-7.5% to +2.5%) at 70% load (47 mA), 67 mA at full load
 Power consumption: 0.75 Watts (from USB port)

ADC Characteristics

Voltage measurement resolution:

| Range (±) | Resolution | Units |
|-----------|------------|-------|
| 10 mV | 0.305 | µV |
| 25 mV | 0.763 | |
| 50 mV | 1.53 | |
| 100 mV | 3.05 | |
| 250 mV | 7.63 | |
| 500 mV | 15.26 | |
| 1 V | 30.5 | |
| 2.5 V | 76.3 | mV |
| 5 V | 152.6 | |
| 10 V | 305 | |
| 25 V | 763 | |
| 50 V | 1.53 | |

Temperature measurement resolution:

| TC type | Resolution | Units |
|---------|------------|-------|
| J | 0.086 | °C |
| K | 0.096 | |
| T | 0.037 | |
| B | 0.096 | |
| R/S | 0.111 | |
| E | 0.073 | |
| N | 0.092 | |

4-20 mA current loop resolution: 13,100 ADC counts over the 4-20 mA range (5 VFS range with 250-Ω shunt resistor)
 Maximum sample throughput rate: Single enabled channel: 2 kHz
 Two or more enabled channels: 200 Hz
 Minimum sample throughput rate: 1 enabled analog channel: 0.000109 Hz
 (Hardware) 2 or more enabled analog channels: 0.000011 Hz
 Min sample throughput rate: .0001969 Hz (with WinDaq software)
 Sample rate timing accuracy: 50 ppm

Indicators, Connections, Controls

Interface: USB 2.0 (mini-B style connector)
 Indicators (LED): Power, Active, Event
 Input connections: Two 16-position terminal strips
 Pushbutton: Manual event when used with WinDaq software

ChannelStretch

WinDaq software: If any synced device has two or more enabled analog channels, all synced devices must enable the same number of analog and digital channels and the same sample throughput rate. If all synced devices have one or zero enabled analog channels, sample rate per channel must be the same across all devices.

Programmed (.Net- or protocol-based): Sample rate per channel must be the same across all synced devices.

*One or more digital ports configured as a discrete input counts as one digital channel. Rate and count inputs count as one digital channel each.

Environmental

Operating temperature: 0 to 35 °C (voltage and TC measurements)
 Storage temperature: -20 to 40 °C
 Storage humidity: 0 to 90 %RH, non-condensing

Physical Characteristics

Enclosure: Hardened Plastic
 Mounting: Desktop; bulkhead
 Dimensions: 6.68W × 3.28D × 1.13H in
 169.67W × 83.31D × 28.7H mm
 Weight: 5.7 oz. (162 grams)

Software Support

WinDaq Software: OS support: Visit <http://www.dataq.com/products/windaq/window-compatibility>.
 Programming: DATAQ Instruments Dot Net SDK, Instrument protocol, DLL, and ActiveX Control

Ordering Guide

| Description | Order No. |
|--|--------------------|
| DI-2008 Millivolt, Volt, Thermocouple, Pulse Data Acquisition System Includes DI-2008 data acquisition hardware, USB cable (6-ft.), screwdriver for screw terminal, WinDaq data acquisition and Playback software, .NET Class and protocol document. | DI-2008 |
| R250 250Ω shunt resistor for 4-20 mA process current loop measurements. | R250 |
| 7-port USB Hub Powered USB hub supports channel expansion applications using ChannelStretch™ | 2000310 |
| 16-ft USB Extension Cable USB 2.0 Type A Extension USB Cable, 16ft. Daisy chain up to 5 cables for extended length. | CBL-100641-16 |
| WinDaq/Unlock Unlocks the DI-2008 to allow ChannelStretch™ support when using WinDaq software. | WinDaq/Unlock-2008 |

DATAQ, the DATAQ logo and WinDaq are registered trademarks of DATAQ Instruments, Inc. All rights reserved. Copyright © 2017 DATAQ Instruments, Inc. The information on this data sheet is subject to change without notice.

We reserve the right to do technical changes without prior notice.

Page 12/12

Germany | Switzerland | Austria

Althen GmbH Mess- & Sensortechnik
 Dieselstr. 2
 65779 Kelkheim, Deutschland
 Tel: + 49 (0)6195 - 70060
 sales@althen.de

Netherlands | Belgium | Luxembourg

Altheris bv Sensors & Controls
 Vlietweg 17a
 2266 KA Leidschendam, The Netherlands
 Tel: +31 (0)70 392 4421
 sales@altheris.nl

France

Altheris Sensors & Controls
 26, avenue de la Méditerranée
 34110 Frontignan, France
 Tél : 0033 (0)4 67 78 61 66
 dbi@altheris.fr

USA | Canada

Altheris Inc Sensors & Controls
 2375 Woodacre Drive
 Oceanside CA 92056, USA
 Tel: +1 858-633-3572
 sales@altheris.com

Other Countries

For our international sales partners please contact us by email at sales@althen.de

 www.althen.de