



**A** FDK Series

---



Certified according to ISO 9001:2008

■ Contents

1.	Safety precautions and measurement conditions .....	3
2.	Electromagnetic compatibility .....	3
3.	General information .....	3
4.	Basic data and performance characteristics .....	3
5.	Example of item designation when ordering .....	3
6.	Complete set to be supplied .....	4
7.	Design .....	4
8.	Operation principle .....	5
9.	Working with the gauge .....	5
9.1.	Gauge turn-on .....	5
9.2.	Single measurement .....	6
9.3.	Measurement with averaging .....	6
9.4.	Gauge turn-out .....	7
10.	Indication parameters setup .....	7
10.1.	Image rotation .....	7
10.2.	Image brightness set-up .....	8
10.3.	Millimeters-Inches-Tapes display set-up .....	8
11.	Service operation modes .....	9
11.1.	Calibration conditions .....	9
11.2.	Get into operational modes .....	9
11.3.	Calibration of the sensor zero .....	9
11.4.	Calibration of the device base .....	10
12.	Charging of built-in accumulator battery .....	11
13.	Warranty policy .....	11
15.	Annex 1. RIFTEK's measurement devices for railway transport .....	12

## 1. Safety precautions and measurement conditions

- The metering accuracy depends greatly on the wheel surface quality. Therefore it is necessary to carry out the check and presorting of the wheel surface roughness and flaws before measuring the diameter.
- Prior to place the gauge onto the wheel there is a need to clean the wheel parts that contact with gauge ball bearings, side supports and measuring tip, of the mud.
- At arranging the gauge, do not allow hitting its supports on the wheel and any measuring tip side hitting
- At arranging the gauge, do not apply strong forcing in the direction of the measuring tip movement. It can result in the gauge sag, that will bring about the uncertain metering result
- It is necessary to inspect the gauge supports periodically and to cleanse them
- To save the battery power the display extinguishes if there were no buttons pressings for 60 seconds, at that only blinking dot is shown. Pressing any button just turns on the display and does not act in any other way in this case.

## 2. Electromagnetic compatibility

The gauge has been developed for use in industry and meets the requirements of the following standards:

- EN 55022:2006 Information Technology Equipment. Radio disturbance characteristics. Limits and methods of measurement.
- EN 61000-6-2:2005 Electromagnetic compatibility (EMC). Generic standards. Immunity for industrial environments.
- EN 61326-1:2006 Electrical Equipment for Measurement, Control, and Laboratory Use. EMC Requirements. General requirements.

## 3. General information

Electronic gauge is designed for measuring wheel rolling circle diameter (amount of wear) of railway, metro and tram in the course of checkup, examination, repair and formation of wheel sets. Measurements are made directly on rolling stock without wheel set roll-out.

## 4. Basic data and performance characteristics

Name of parameter	Value
Measurement range, mm	400...1400 or on request
Measurement error, mm	±0.2
Indication discreteness	0.1mm, 0.01mm * or 0.01 inch **
Position of measurement, S, mm	On request
Distance between axes of ball bearings (base), mm and diameters measurement range, mm	122±0.5 (400...750 mm) or 200±0.5 (400...950 mm) or 250±0.5 (600...1400 mm) or 300±0.5 (720...1400 mm)
Display	build-in, LED
Operating temperature, °C	-5...+55
Weight, kg	<0,5

## 5. Example of item designation when ordering

FDK-S/B-MIN/MAX-X

Symbol	Description
S	Position of measurement, mm
B	Base, mm
MIN	Bottom of measuring range, mm
MAX	Up of measuring range, mm
X	Position of indication. A – Indication is at the side of side supports (figure A), B – Indication is at opposite side (figure B)

**Example:** FDK-70/250-850/1260-A. Position of measurement – 70 mm; base of the gauge – 250 mm; bottom of measuring range – 850 mm; up of measuring range – 1260 mm; position of indication – B

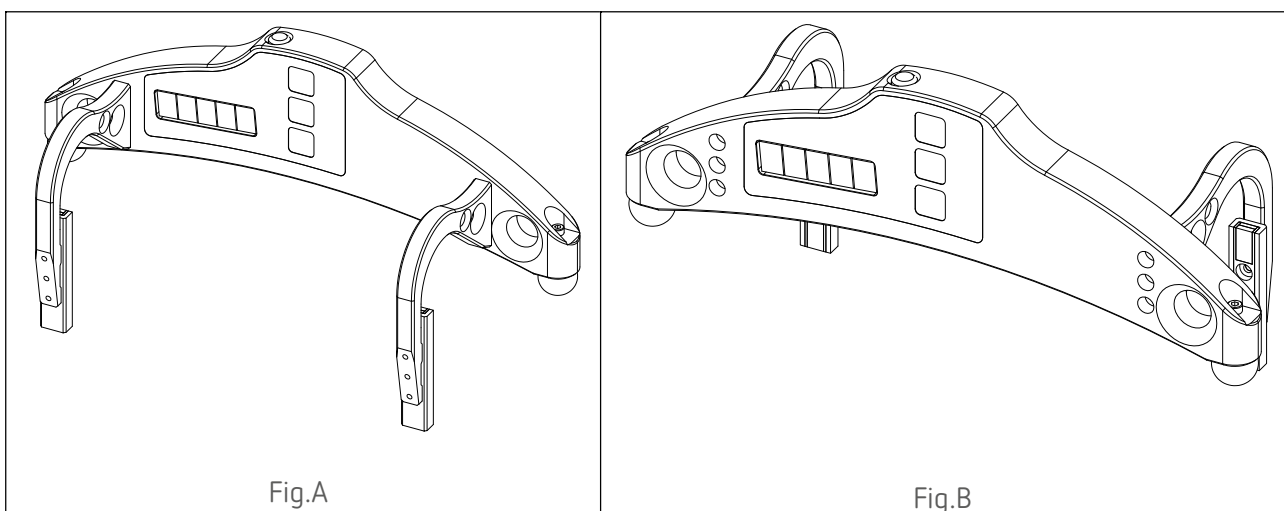

Fig.A

Fig.B

## 6. Complete set to be supplied

Name	Quantity	Weight, kg
Wheel diameter measuring gauge IDK series	1 piece	0,5
Charger	1 piece	0,2
Manual	1 piece	
Case	1 piece	
Calibration tools (option)	on request	
Flat block FDRF510.11.000 (fig.2)	-	
Reference wheel block for calibrating FDRF510.11.XXXX (fig.3)	-	

## 7. Design

Electronic gauge contains two ball supports to place the gauge onto the roll surface, two side supports to base the gauge to the wheel edge and a measuring tip. There are a digital numeric display and control buttons on the front panel of the gauge. "Charge" connector for charging device connection is situated on the top panel of the gauge. Accumulator batteries (two AAA 1,2V) are a source of power supply. The accumulator batteries are easy to change too.

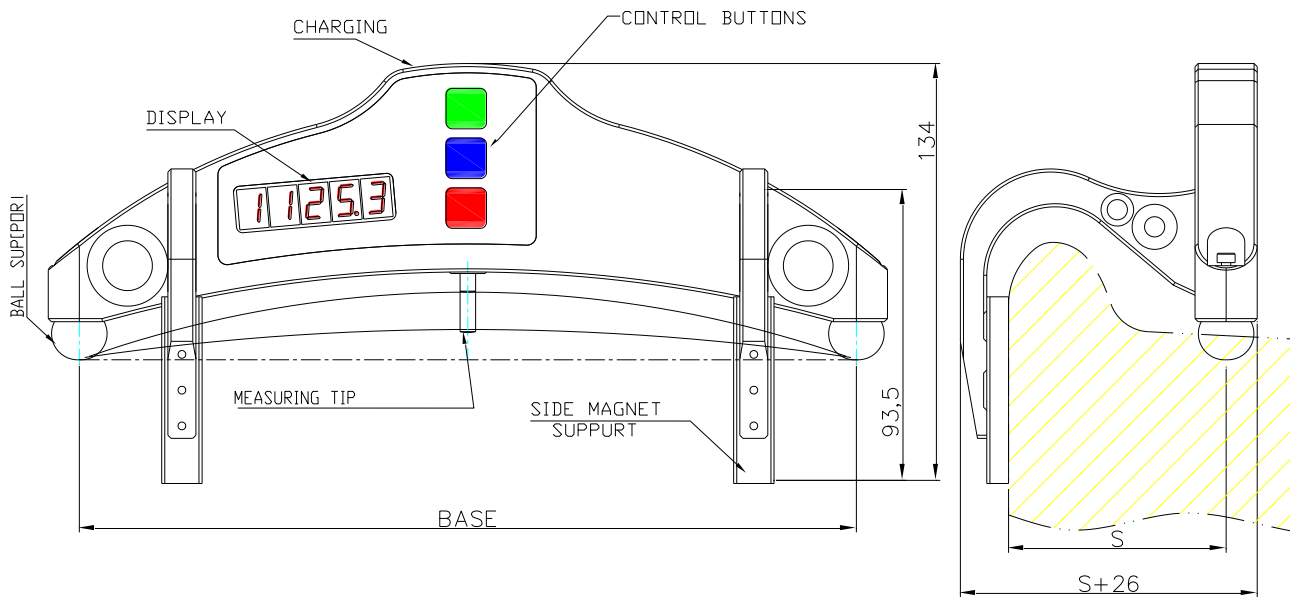

Figure 1

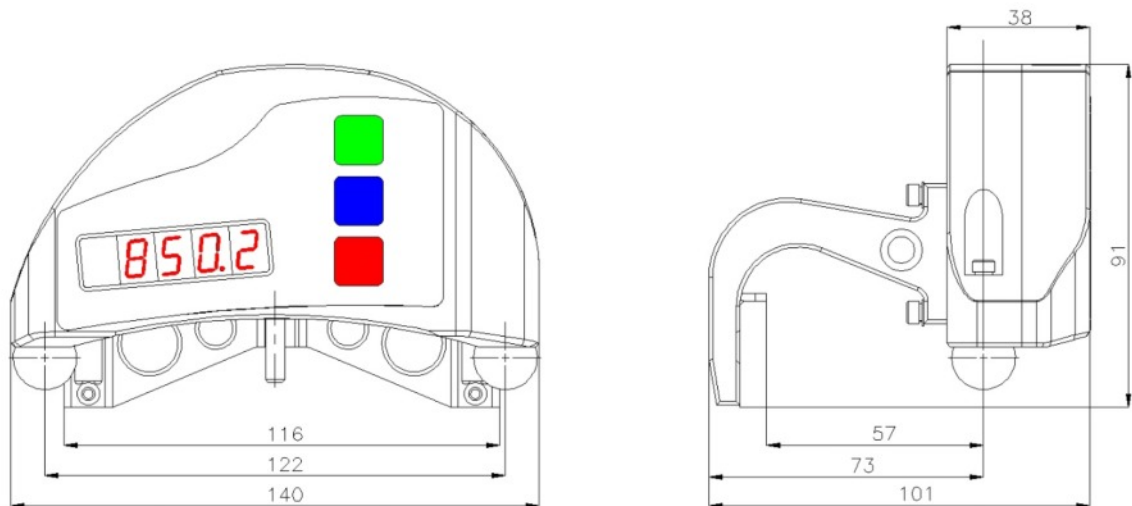

Figure 1.1

## 8. Operation principle

The measurement of the diameter is performed according to the "three points" technique, without the complete wheel coverage. The measurement method is based on the diameter calculation by the known length of the segment chord (the distance between the ball bearings centers), which is obtained at placing the gauge onto the wheel.

The saggita of the segment is measured by means of the displacement converter. Video presentation is available on request.

## 9. Working with the gauge

### 9.1. Gauge turn-on

Press **Red** button to turn on the power. The display shows "**ErrP**" message if the accumulator battery voltage became lower then the control level. In this case the short-term work is possible after pressing any key.

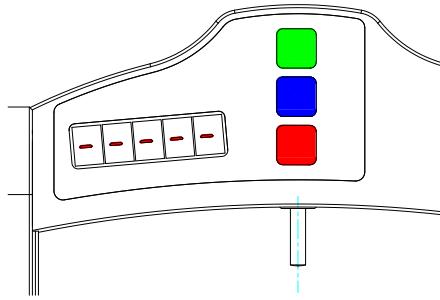

## 9.2. Single measurement

To perform measurement, it is necessary to:

- turn the power on (press **Red** button). The display shows “- - - - -”;
- place the gauge onto the wheel;
- make sure the ball supports are tight against the roll surface and side supports are adjacent to the edge of the wheel;
- press **Green** button.
- in a 1 second the display will show the value of the wheel diameter.

For viewing the result of measurement with indication discreteness of **0.01mm** (it is accessible only in a mode of direct indication) it is necessary to press **Blue** button, thus displayed result will be shifted to the left on one digit. Next pressing **Blue** button will lead to return of indication to a starting position:

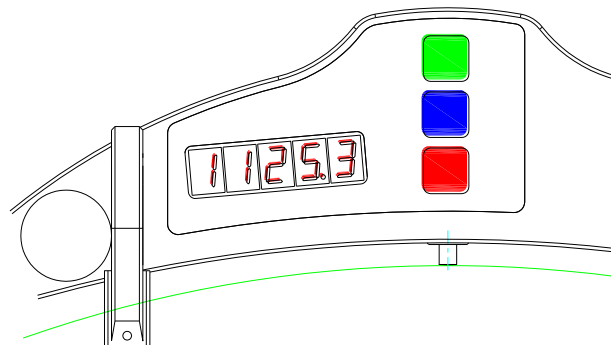

## 9.3. Measurement with averaging

The program of the wheel diameter calculation contains an averaging algorithm that allows eliminating the surface defects influence on the diameter measuring result. All the results of metering, performed after the **Red** button pressing, are averaged. The measurement is meant to be **Green** button pressing.

To carry out measurements it is necessary to

- turn the power on (press **Red** button). The display shows “- - - - -”;
- place the gauge onto the wheel
- make sure the ball supports are tight against the roll surface and side supports are adjacent to the edge of the wheel;
- press **Green** button;
- display shows the value of pressing counter “n        x”, where **x** – quantity of averaged values;
- in a 1 second display shows an average value over the set of metering (over the quantity of **Green** button pressings)
- move the gauge to a new position and repeat the measuring.  
(The total quantity of measurements averaged in this way can run up to 9999.)

- Press **Red** button to reset averaging result at switching to another wheel.  
For viewing the result of measurement with indication discreteness **0.01mm** (it is accessible only in a mode of direct indication) it is necessary to press **Blue** button, thus displayed result will be shifted to the left on one digit. Next pressing **Blue** button will lead to return of indication to a starting position.

#### 9.4. Gauge turn-out

The gauge turn-out occurs automatically. The display extinguishes if there were no buttons pressings for 60 seconds, at that only blinking dot is shown. If there were no button pressings for 4 more minutes, the gauge is turned out completely. You can turn the gauge off by long pressing **Red** button (more then 3 sec.).

## 10. Indication parameters setup

### 10.1. Image rotation

To rotate the image it is necessary to:

- turn the power on (press **Red** button);

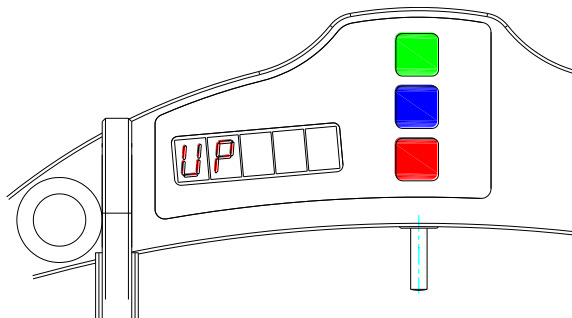

- press **Blue** button and keep it pressed for more than three seconds;
- display will show "Up";

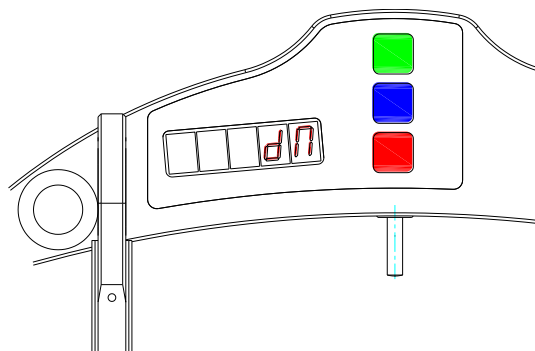

- by the pressing of **Green** button turn over the image: the message "Up" will be turned over 180°;
- to save the changed parameters press **Red** button. The display shows "SAUE" message, press the **Green** button to confirm saving and **Red** to cancel saving of the changed parameters;

Image rotation function allows observing the result in the way comfortable for the operator regardless of the gauge placement direction.

#### Notes:

- indication discreteness of **0.01mm** is accessible only in a mode of direct indication;

- the separation point is indicated at the top side of the screen in the reverse indication regime.

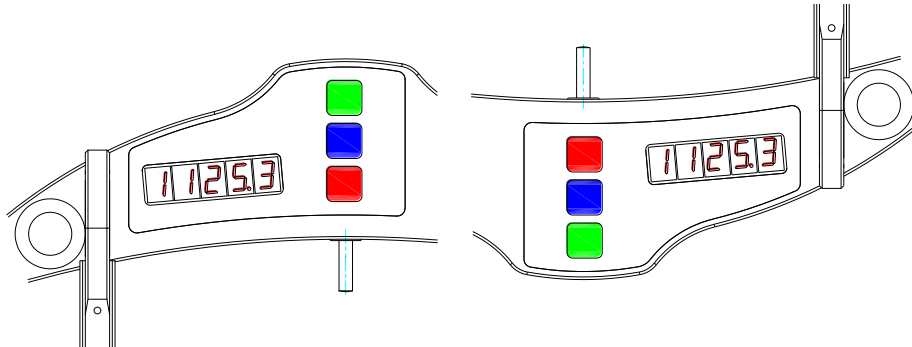

## 10.2. Image brightness set-up

To change the display brightness it is necessary to:

- turn the power on (press **Red** button).;
- press **Blue** button and keep it pressed for more than three seconds;
- display will show "Up";
- press **Blue** button again than "brt X" message appears on the display;

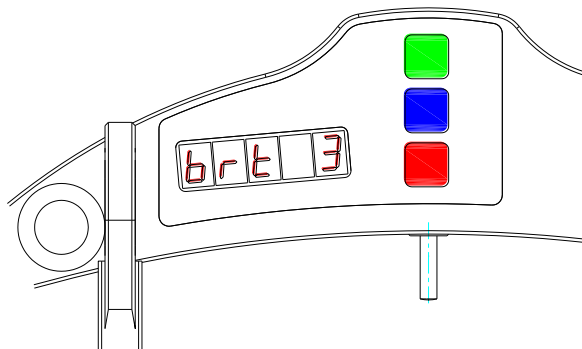

- choose the necessary brightness value by **Green** button pressings;
- to save the changed parameters press **Red** button the display shows "SAUE" message, press the **Green** button to confirm saving and **Red** to cancel saving of the changed parameters;

At brightness choosing one should take into account that increased brightness enhances power consumption and decreases the period till battery recharge moment.

## 10.3. Millimeters-Inches-Tapes display set-up

To change the mode it is necessary to:

- turn the power on (press **Red** button).;
- press **Blue** button and keep it pressed for more than three seconds;
- display will show "Up";
- press **Blue** button again until the either "SI" or "Inch" message appears on the display. "SI" – measuring results will be shown in mm, "Inch" – measuring results will be shown in inches, "Tape";
- choose the necessary value by **Green** button pressings;
- to save the changed parameters press **Red** button the display shows "SAUE" message, press the **Green** button to confirm saving and **Red** to cancel saving of the changed parameters



## 11. Service operation modes

This section contains the description of the modes for the check of device efficiency and calibration. As erroneous actions in this mode can lead to invalid measurement results, only specially trained personnel should perform such operations.

### 11.1. Calibration conditions

**Calibration of the device is not necessary in the current work. It is necessary only after producing, repairing and also after checking with negative result.**

To perform calibration the following means are necessary:

- Calibration plate with the deviation from flatness less than  $\pm 0,5$   $\mu\text{m}$  for 250 mm length (or Flat block FDRF510.11.000, figure 2);
- Johansson gauge;
- reference wheel of the known diameter (or Reference wheel block FDRF510.11.XXXX, figure 3)

### 11.2. Get into operational modes

- To get into the operational modes it is necessary to turn-off the device (press **Red** button more than 3 seconds).
- Keeping **Green** button in pushed position turn-on the device (press **Red** button).
- Display shows "CLbr.0" message (the mode of calibration of the sensor's "0").
- To get into this mode it is necessary to press **Green** button (see. p. 11.2).
- For transition to next mode it is necessary to press **Blue** button.
- Display shows "CLbr.b" message (the mode of device base calibration).
- To get into this mode press **Green** button (see. p.11.3).
- To get out the mode of calibration press **Red** button.

### 11.3. Calibration of the sensor zero

- Zero calibration mode being enabled, the display shows the Johansson gauge value used for calibration in increments of 0.5  $\mu\text{m}$ .
- If editing of the Johansson gauge value is not required, go to the next step. To edit the Johansson gauge value, press the **Blue** button, and the digit to be edited starts blinking. Changing over between the digits is made by pressing the **Blue** button while changing of values is made by pressing the **Green** button. When editing is finished, press the **Red** button and confirm or cancel saving of the parameter by pressing the **Green** button or **Red** button, respectively.
- Press the **Green** button, and the Johansson gauge value starts blinking, which means that the device must be placed onto a flat plate and a Johansson gauge with nominal value of the previous step must be placed under the measuring tip. The Johansson gauge must be tightly fitted to the flat plate and supports and balls of the device must be firmly forced against the plate.
- Press the **Green** button, and the display shows current reading of the sensor in its own coordinate system. By moving the device, assure that repeatability of measurement results is obtained.

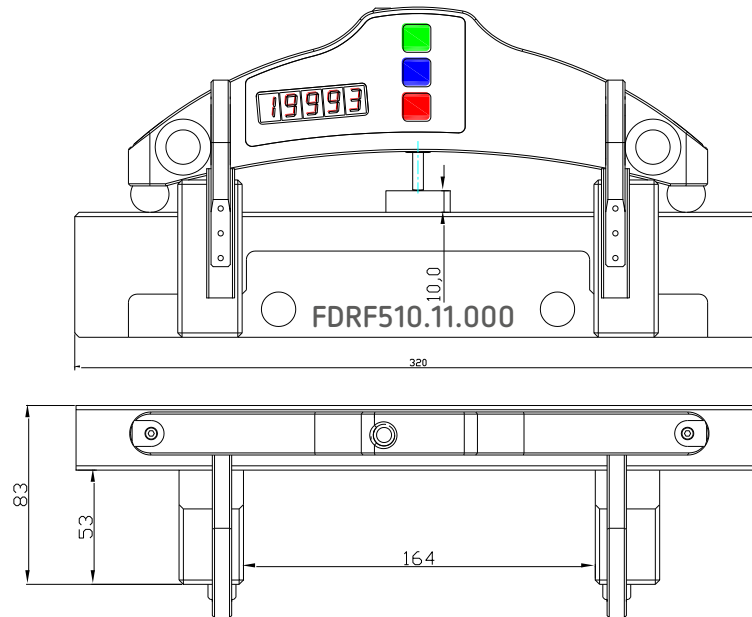

Figure 2

- If readings of the sensor are sufficiently stable, press the **Blue** button. Sensor zero position is calculated in the device coordinate system, and prompt appears to save calibration results. Press the **Green** or **Red** button to confirm or cancel saving of the results, respectively.

#### 11.4. Calibration of the device base

- Device base calibration mode being enabled, the display shows the value of reference diameter used for calibration.
- If editing of the diameter value is not required, go to the next step. To edit the diameter value, press the **Blue** button, and the digit to be edited starts blinking. Changing over between the digits is made by pressing the **Blue** button while changing of values is made by pressing the **Green** button. When editing is finished, press the **Red** button and confirm or cancel saving of the parameter by pressing the **Green** button or **Red** button, respectively.
- Press the **Green** button, and the reference diameter value starts blinking, which means that the device must be placed onto a gage with the diameter value set at the previous step. The device supports must be firmly forced against the reference block.
- Press the **Green** button, and the display shows current reading of the sensor in the device coordinate system. By moving the device, assure that repeatability of measurement results is obtained.
- If readings of the instrument are sufficiently stable, press the **Blue** button. Device base value is calculated, and prompt appears to save calibration results. Press the **Green** or **Red** button to confirm or cancel saving of the results, respectively.

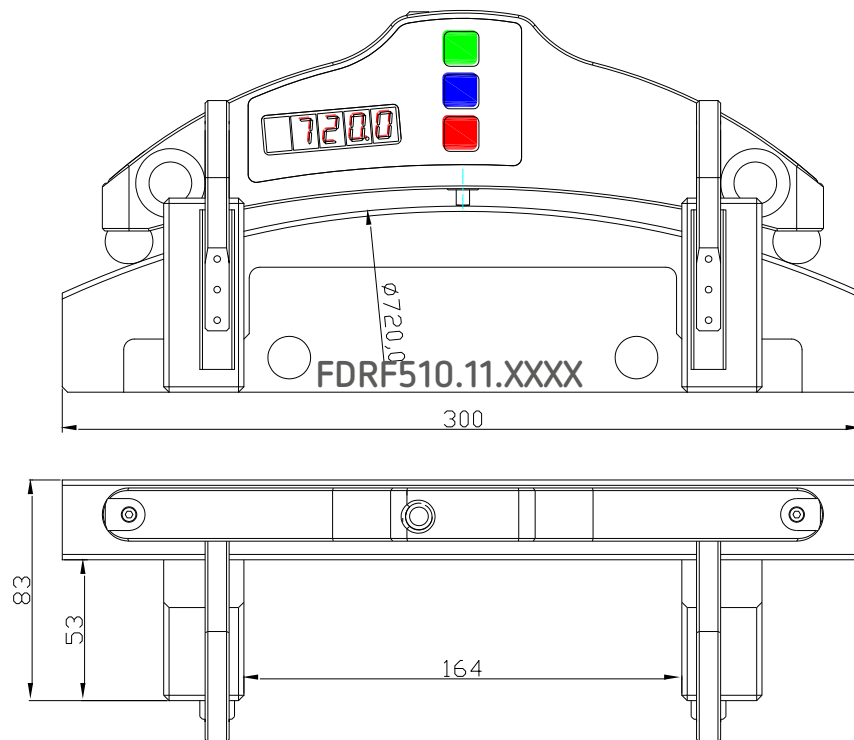

Figure 3

**NOTE:** Video-help for calibration procedure is available on request.

## 12. Charging of built-in accumulator battery

To charge accumulator battery it is necessary to connect charging device to the power grid 85-250V and to a battery compartment on the top panel of the gauge. The period of charging is 15 hours.

## 13. Warranty policy

Warranty assurance for the Wheel diameter gauge - 24 months from the date of putting in operation; warranty shelf-life - 12 months.

## 15. Annex 1. Measurement devices for railway transport



### Laser wheel profilometer. FDKP Series

A laser profilometer is designed for the measuring of:  
wheel flange height;  
wheel flange thickness;  
wheel flange slope;  
full profile scanning and analyze of wheel rolling surface;  
maintaining of electronic wear data base;  
control of tolerances and sorting in the course of checkup, examination, repair and formation of railway wheel sets;  
Measurements are made directly on rolling stock without wheel set roll-out.



### Portable laser rail profilometer. FPRP Series

The main functions of FPRP are:

- obtaining the information on the cross-section profile of the working railhead surface;
- full profile scanning and analyze of the railhead acting face;
- visualization of the combined graphical images of actual and new cross-section railhead profiles on the display of system unit.



### Wheel diameter measuring gauge. FDK Series

Electronic gauge is designed for measuring wheel rolling circle diameter of railway, metro and tram wheel sets.

Measurements are made directly on rolling stock without wheel set roll-out.



### Back-to-back distance measuring gauge. FDIRM Series

Gauge is designed for contactless measuring of back-to-back distance of railway, metro and tram wheels in the course of checkup, examination, repair and formation of wheel sets. Measurements are made directly on rolling stock without wheel set roll-out.



### Back-to-back distance measuring gauge. FDIRM-L Series

Gauge is designed for contactless measuring of back-to-back distance of railway, metro and tram wheels in the course of checkup, examination, repair and formation of wheel sets. Measurements are made directly on rolling stock without wheel set roll-out.



### Disc brakes profile gauge. FBD Series

Laser disc brakes profilometer FBD Series is designed for disc brakes profile measuring.

The main functions of FDD are:

- obtaining the information on the profile parameters of the working disc brakes surface;
- full profile scanning and analyze of the disc brakes acting face;
- visualization of the combined graphical images of actual and new disc brakes profiles on the display of system unit.



### Automatic real-time system for measurement of wheel-sets geometrical parameters

The system is designed for contactless automatic measurement of geometrical parameters of railway wheels and uses a combination of 2D laser scanners, mounted wayside in the track area.

The system can be easily installed at any type of rail infrastructure.