



g LCF-3500

Description

- Input From $\pm 0.5g$ to $\pm 5.0g$
- Full Range
- Exceptional Bias and Scale Factor
- Specifically Designed for High Shock and Vibration Environments.



The LCF-3500 Series Flexure Suspension Fluid Damped Tri-Axial Accelerometer is a $\pm 0.5G$ to $\pm 5G$ device designed for applications where high levels of shock and vibration are present. LCF units are characterized by excellent turn on repeatability and very low hysteresis.

Features

- $\pm 0.5g$ to $\pm 5.0g$ Full Range
- Filtering 5 to 100 Hz Bandwidth Available
- Exceptional Bias & Scale Factor
- High Level ± 5 Vdc Output
- 1,000g Shock Capability
- Tri-Axis

Applications

- Geophysical Testing
- Railcar Acceleration Control
- Railcar Deceleration Control
- Ocean Buoy Acceleration Sensing
- Aircraft Stability Control
- Aircraft Flight Testing
- Vehicle Roadway Profiling
- Tri-Axis Acceleration Applications
- Aircraft Flight Data Recorder

Outline Diagram

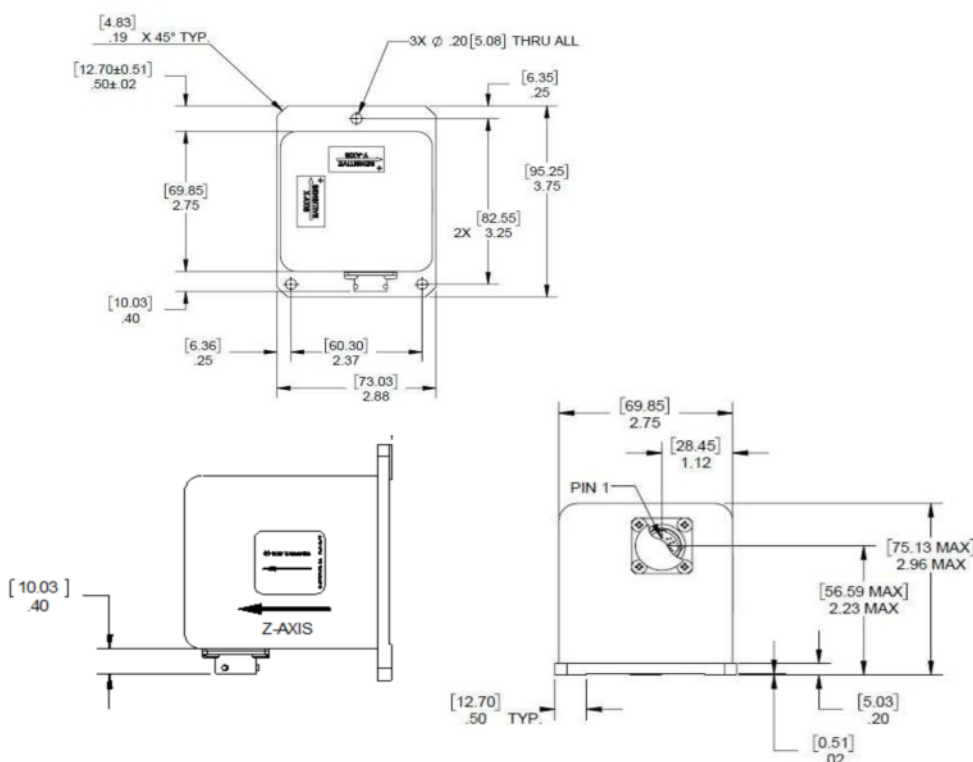

Pin Out

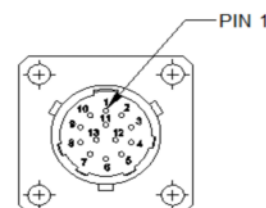

CONNECTOR: MS27476Y10D35P
MATE: MS27473T10B35S

CONNECTOR INTERFACE	
PIN	FUNCTION
1	+15 VDC
2	-15 VDC
3	COMMON
4	X OUTPUT
5	Y OUTPUT
6	Z OUTPUT
7-13	N/C

■ Performance Specifications

STATIC/DYNAMIC

Input Range (g) (Note 1)	± 0.50	± 2.0	± 5.0
Full Range Output (FRO), volts ± 0.5%	± 5.0	± 5.0	± 5.0
Non Linearity (%FRO Max.) (Note 2)	0.05	0.05	0.05
Scale Factor, volts/g (Nominal)	10.0	2.50	1.00
Scale Factor Temp. Sens., (PPM/°C, Max.)	100	100	100
Bias, g (Max.)	0.005	0.005	0.005
Bias Temp. Sens., micro g/° (Max.)	100	100	100
Natural Frequency, Hz min (Note 3)	30	30	30
Bandwidth (-3dB), Hz min	30	30	30
Input Axis Misalignment, ° (Max.)	1.0	1.0	1.0
Resolution and Threshold, micro g (Max.)	10	10	10

ELECTRICAL

Input Voltage, VDC	±12 to ±18
Input Current (mA, Nominal):	±45
Output Impedance, ohms (Nominal)	100
Noise, Vrms (Max.)	0.002

ENVIRONMENTAL

Operating Temp Range	-40 to+80°C
Survival Temp Range	-60 to+90°C
Vibration	20 grms
Shock	1000g, 1 msec, ½ sine
Seal	Epoxy

Notes: 1 - Full range is defined as "from negative to positive full input acceleration." 2
 - Referenced to best-fit straight line independent of misalignment.
 3 - Output phase angle = -90°.

Custom Capabilities

- Unit Power Connections can be easily adapted for operations from single-ended, floating power supplies of 24 to 36 Volts DC
- Internal Temperature Sensor
- 4-20 mA output

■ Order code

LCF-3500-.5g/.5g/.5g
 LCF-3500-2.0g/2.0g/2.0g
 LCF-3500-5.0g/5.0g/5.0g