



MONODAQ-U-X

Multifunctional, isolated USB data acquisition device for voltage, current, temperature, strain and resistance measurement.

MonoDAQ-U-X is a fully isolated USB test & measurement device with full software support in DEWESoft data acquisition software. 8 multifunctional front pins can be configured as analog or digital inputs or outputs.



FEATURES

- Power and signal isolation between USB and front end
- Max. sample rate: 50 kS/s, resolution: 16 bit
- Can connect up to 2 full bridge strain gauges or up to 4 thermocouples
- Max. 4 differential or 8 single ended voltage inputs
- Current input with internal shunt (0.5 ohm)
- Analog output (+/- 4 V, 14 bit, 50 kS/s)
- Max. 8 digital inputs or outputs
- 1wire, I2C and UART interface on front connector
- Internal humidity sensor
- Internal IMU (3-axial accelerometer and 3-axial gyroscope)

APPLICATIONS

- Embedded IoT system power consumption measurement
- Analog measurement front end for industrial machines and test benches
- Strain measurement in industrial quality control
- Industrial condition monitoring (voltage, temperature, current)
- Precision measurement front end for single-board computers (Raspberry Pi, LattePanda etc.)
- Precise laboratory power supply for board development

OVERALL WORKING PRINCIPLE

MonoDAQ-U-X is powered from the USB-C port on the backplane, therefore a single USB-C cable is needed for communication and power supply. Power and communication signals are isolated directly after the USB connector, which makes the microcontroller and the front end of the device fully galvanically isolated. Front end connector features 8 multifunctional pins that can be configured as analog inputs or outputs or as digital inputs or outputs. Front end is configured with the help of a channel setup table in DEWESoft software.

At the core of the measurement chain is a sigma-delta ADC with a maximum sample rate of 50 kS/s and a resolution of 16 bit. If only one input channel is used, the signal is alias-free with bandwidth of $0.4 \cdot f_s$ (sampling frequency). If multiple analog input channels are used, the signals are multiplexed in front of the ADC. It is possible to select up to 8 single ended voltage inputs and up to 4 differential voltage inputs. Half of the channels can have a high input range of 10 V while the other half are limited to 2 V since there is no voltage divider on those channels.

SYNCHRONIZATION BETWEEN DEVICES

Multiple MonoDAQ-U-X devices can be connected to the same PC by using a multiport USB hub. Synchronization between devices is ensured if all of the devices are connected to the same hub. Multiple hubs can be connected to the top-level hub but refer to MonoDAQ support for compatible USB hubs on the market.





MONODAQ-U-X CAPABILITIES AND SPECIFICATION / ANALOG INPUTS – GENERAL SPECIFICATION

Maximum sample rate (1 channel)	50 kS/s
Maximum sample rate (multiplexed)	20 kS/s / nr. of channels
Note on sample rates	On ± 100 mV, 4V and 5V input ranges max sample rate is 20 kS/s for 1 channel and 5 kS/s / nr. of channels in multiplexed mode. If ± 100 mV and ± 10 V ranges are used at the same time (on two different channels in mux mode), max sample rate is 1 kS/s / nr. of channels .
Resolution	16 bit
Max. number of differential voltage inputs	2 (± 10 V... ± 100 mV range) or 4 (2 V... ± 100 mV range)
Max. number of single ended voltage inputs	4 (± 10 V... ± 100 mV range) or 8 (5 V... ± 100 mV range)
Max. number of current inputs	1 (0.5 ohm internal shunt, 500 mA rated, measuring range 2 A)
Max. number of strain gauge inputs	4 (single excitation source)
Max. number of thermocouple inputs	4
Alias-free bw (single channel mode)	0.4*fs
Temperature drift	50 ppm/K (non-buffered inputs), 200 ppm/K (buffered inputs); offset error is compensated on start of each measurement

ANALOG INPUT ACCURACY

Input type	Range	Error
Single ended or differential	100 mV	+/-0.1% of reading +/-30 μ V
Single ended or differential, buffered	100 mV	+/-0.2% of reading +/-40 μ V
Single ended or differential	1 V ... 10 V	+/-0.1% of reading +/-1 mV
Single ended or differential, buffered	1 V ... 10 V	+/-0.2% of reading +/-1 mV

THERMOCOUPLE INPUT ACCURACY

Cold junction compensation error	+/- 1 deg C
K type thermocouple error at 200 deg C reading	+/- 2 deg C

Notes:

- All accuracy values are typical and are valid in the ambient temperature range of +/- 2.5 deg C from the calibration temperature
- calibration temperature for each device is given on the factory calibration sheet, typically 23 deg C

ANALOG INPUT DYNAMIC PERFORMANCE

Input type	Range	Sample rate [S/s]	AC RMS noise	PP noise	Noise floor [dB]	SNR [dB]	THD [dB]	SFDR [dB]
Differential	100 mV	10000	10 μ V (-80 dB)	82 μ V (-62 dB)	-88	70	-80	81
Differential	100 mV	1000	4 μ V (-87 dB)	33 μ V (-70 dB)	-95	78	-87	89
Differential	1 V	10000	46 μ V (-86 dB)	360 μ V (-68 dB)	-104	81	-63	67
Differential	1 V	1000	40 μ V (-88 dB)	210 μ V (-74 dB)	-107	87	-70	72
Differential buffered	10 V	10000	300 μ V (-90 dB)	2,5 mV (-72 dB)	-100	83	-85	86
Differential buffered	10 V	1000	200 μ V (-94 dB)	1 mV (-80 dB)	-103	89	-95	96
Single ended buffered	10 V	10000	320 μ V (-90 dB)	2,3 mV (-72 dB)	-98	83	-89	90
Single ended buffered	10 V	1000	250 μ V (-92 dB)	1,1 mV (-78 dB)	-102	86	-97	97

Notes:

- all dynamic signal characteristic values in the table above are typical values measured with a single active channel on the device
- AC RMS noise: RMS of the signal, high-pass filtered at 10 Hz, measured with input shorted
- PP noise: Peak-Peak value of the signal, measured with input shorted
- Noise floor: horizontal noise floor of the FFT from 10 Hz upwards, dB relative to the range, measured with input shorted
- SNR: dynamic signal to noise ratio, measured with a reference sinusoidal signal at the input (amplitude: -1 dB of range, frequency: 10% of the sampling rate)

- THD: total harmonic distortion, measured with a reference sinusoidal signal at the input (amplitude: -1 dB of range, frequency: 10% of the sampling rate)
- SFDR: spurious-free dynamic range, measured with a reference sinusoidal signal at the input (amplitude: -1 dB of range, frequency: 10% of the sampling rate)

ANALOG INPUT FREQUENCY RESPONSE

Figures below show the attenuation of analog signal from 10 Hz to 1 MHz. Performance is similar for all types of inputs. Noise floor is higher due to the function generator used in the test, for the actual values use the table above.

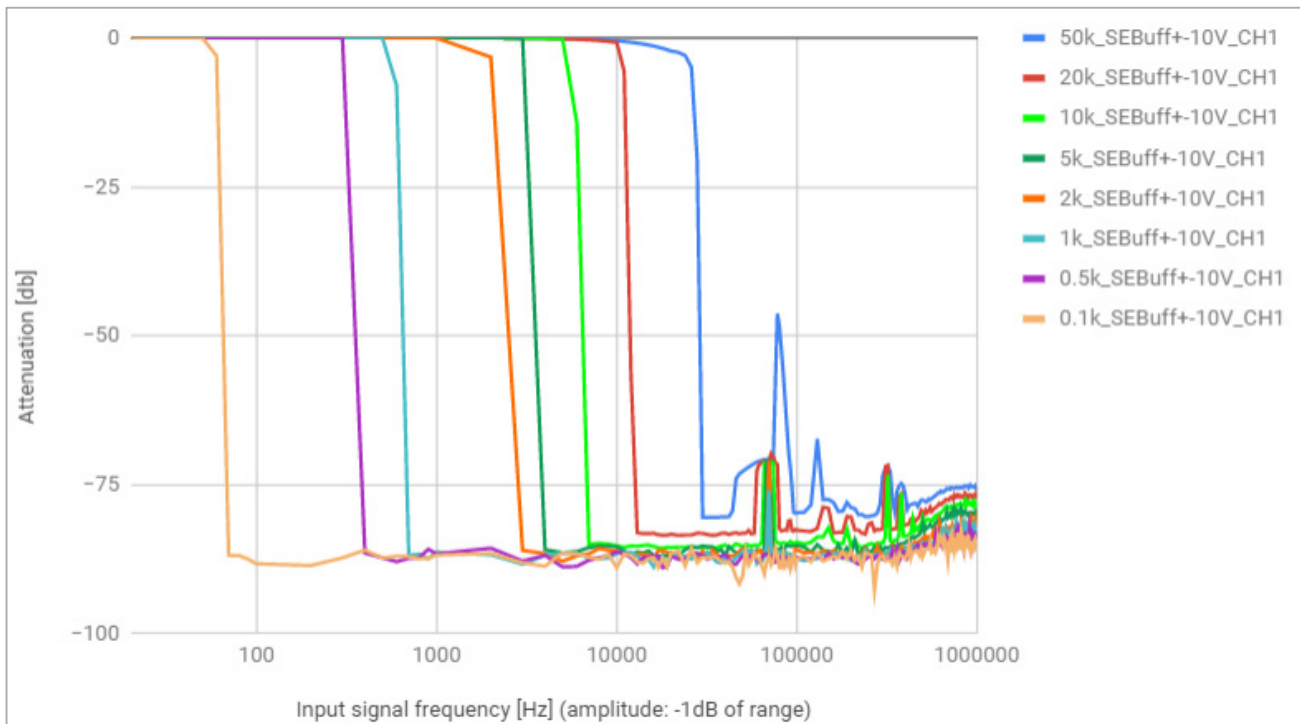

Analog input frequency response – single channel mode, buffered single-ended input, different sample rates

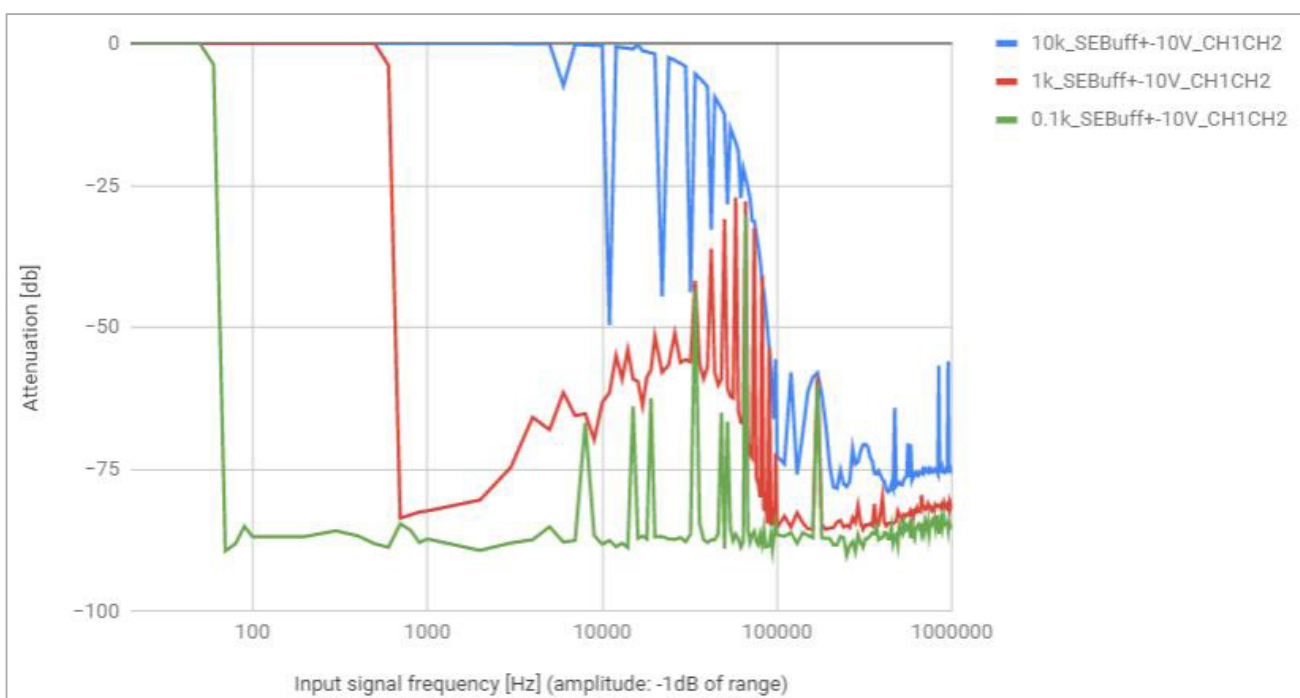

Analog input frequency response – multi channel mode (mux), buffered single-ended input, different sample rates

**EXCITATION & FRONT END POWER SUPPLY**

Number of sources	1
Low-noise preset levels	2 V, 3.3 V, 5 V, 10 V, 24 V (<1 uVrms noise)
Settable voltage	1.2 V ... 24 V (<1 mVrms noise)
Current Limiter	0 .. 200 mA
Max Power	1 W

ANALOG OUTPUT

Max. streaming sample rate	50 kS/s****
Max. internal sample rate (predefined forms)	500 kS/s
Resolution	12 bit (no missing codes)
Range	0 ... 4 V

DIGITAL INPUTS/OUTPUTS

Max. number of digital inputs	4 (33 MHz max counting rate) or 8 (1 MHz max. counting rate)*
Max. number of digital outputs	8
Max. input level	10 V
Input type	TTL, CMOS
Output levels	2 V, 3.3 V, 5 V
Output type	TTL, CMOS

CLOCK

Accuracy	synchronized to USB or standalone 10 ppm
Device to device jitter (ref. to USB accuracy)	<1 us typ.

OTHER

Supported front end digital bus (D10, D11 pins)	I2C**, UART**, 1WIRE**
Internal monitoring sensors	Humidity, temperature, 6-axis IMU

ISOLATION

Type of digital isolation	Optocouplers on USB transmission lines
Type of power isolation	Transformer between the USB power supply and device internal power supply
Isolation level	Functional isolation***

ENVIRONMENTAL & STANDARDS

Operating temperature	-10 ... 50 degC
Max. power consumption	2.5 W (500 mA @5 V)
Tested according to	IEC-61010, IEC-61326

Notes:

- * 33 MHz and 8 MHz digital input sampling speeds are possible in hardware. The present software implementation only allows to sample the digital inputs at the speed of the analog voltage inputs (max. 50 kS/s). In case of a higher speed requirement for the digital inputs, please contact support@monodaq.com
- ** I2C, UART and 1WIRE are supported in hardware. The communication control from software is not implemented in this release of the product. Contact support@monodaq.com for specific requirements regarding those protocols as each external device needs to be supported on a project basis
- *** hardware components, clearance and creepage distances inside the device allow the possibility to certify the product for 125 Vrms CAT II working voltage, but the present release of the product should under no condition be used with voltages higher than 30 V. Contact support@monodaq.com if higher isolation voltage rating is needed.
- **** specification lists hardware capabilities of analog output. Present Dewesoft software support allows a maximum analog output value update rate of 10 Hz.

SOFTWARE SUPPORT

MonoDAQ-U-X is supported in DEWESoft X3 data acquisition software. MonoDAQ-U plugin is necessary on top of the DEWESoft X3 (SP4 release) installation. Plugin provides the user with a channel configuration table that sets the functions of the front pins. Data from the devices is seen in regular DEWESoft channels and can be used in other functions of the software packages such as Math section and other plugins. For custom applications the device is also supported in Isotel IDM cross-platform software package

based on Java. IDM can be installed on any operating system supporting Java and provides the basic interface to the device for configuration and data streaming. There is Python API available to access the device through IDM software.

MECHANICAL DRAWINGS

MonoDAQ-U-X originally comes in an aluminium housing that allows quick stacking of multiple devices. It is also possible to order the OEM-version without housing for building-in.

DIMENSIONS WITH HOUSING

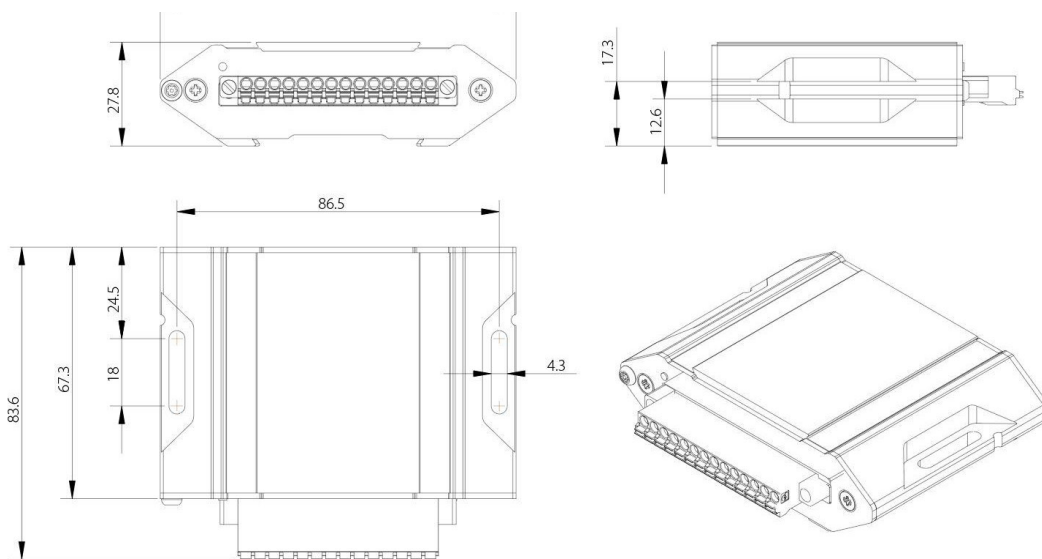

PCB-ONLY DIMENSIONS

