



bar

MPM280 Piezoresistive OEM Pressure Sensor

FEATURES

- Pressure range: 0kPa ~ 35kPa...100MPa
- Gauge, absolute and sealed gauge Constant current / Constant Voltages power supply
- Isolated construction to measure various fluid media
- Ø19mm OEM pressure element
- 316L stainless steel material
- Tantalum diaphragm or titanium construction for option
- Different male thread connection optional

General MPM280 Piezoresistive Pressure Sensor

The outline, installation dimension and sealing method of General MPM280 is strongly interchangeable, it is widely used for measuring pressure which is compatible with stainless steel and Viton.

Assembled MPM280 Piezoresistive Pressure Sensor Put general MPM280 pressure sensor into the housing with standard or specialized thread; use face type seal or waterline seal; with flexible construction and strict inspecting and screening; **Welded MPM280 Piezoresistive Pressure Sensor** Put general MPM280 pressure sensor into the housing with standard or specialized thread; and weld sensor with housing together, no O-ring for sealing. The whole product has flexible construction, it has wider application fields than general pressure sensor, and can be used for mounting and production of different pressure instruments. **Flush Diaphragm MPM280 Piezoresistive Pressure Sensor** Flush diaphragm pressure sensor is a pressure sensing element through male thread and clamp connection. It has pressure port G1/2 male, R1/2 male, M20x1.5 male and DN25 clamp, sealed by Viton or silicon O-ring. The isolated diaphragm is welded in front of thread port, the range is 0kPa~100kPa...35MPa(thread connection) and 0kPa~100kPa... 3.5MPa(clamp connection).

Anti-corrosive MPM280 Piezoresistive Pressure Sensor MPM280TH pressure sensor has similar outline, installation dimension and sealing methods as general MPM280 pressure sensor. For construction material, the isolated diagram uses tantalum material and housing uses Hastelloy C material. The sensor is sealed by Viton O-ring. It can be used to measure

strongly corrosive media. The pressure range is -100kPa~0kPa; 0kPa~100kPa...35MPa. MPM280TS pressure sensor has similar outline, installation dimension and sealing methods as general MPM280 pressure sensor. For construction material, the isolated diagram uses tantalum material and housing uses stainless steel 316L material. The sensor is sealed by Viton O-ring. It can be used to measure strongly corrosive media. The pressure range is -100kPa~0kPa; 0kPa~100kPa...35MPa. MPM280HH pressure sensor has similar outline, installation dimension and sealing methods as general MPM280 pressure sensor. It uses all Hastelloy C material in construction, The sensor is sealed by Viton O-ring. It can be used to measure strongly corrosive media. The pressure range is -100kPa~0kPa; 0kPa~100kPa...35MPa. MPM280Ti pressure sensor has similar outline, installation dimension and sealing methods as general MPM280 pressure sensor. It uses all titanium material in construction, TC4 housing material and TA1 diaphragm. It can be used to measure sea water or corrosive media. The pressure range is -100kPa~0kPa; 0kPa~100kPa...70MPa. MPM 280Ti Piezoresistive Pressure Sensor can be used in wet environment or sea water. Its anti-corrosive performance is far better than stainless steel. MPM280Ti has good anti-corrosive performance for pitting, acid etching, stress corrosion, alkali, chloride, chlorine-organism, nitric acid and vitriol etc. Gauge MPM280 Pressure Sensor with Vacuum Measurement We can use gauge type of general, assembled and flush diaphragm type MPM280 to measure pressure below air pressure, the min. pressure can be around -100kPa.





■ APPLICATIONS

- Industrial process control
- Level measurement
- Gas, liquid pressure measurement
- Pressure meter
- Pressure calibrator
- Liquid pressure system and switch
- Refrigeration equipment and air conditioner
- Aviation and navigation inspection

■ BASIC CONDITION

- Media temperature: (25±1)°C
- Environment temperature: (25±1)°C
- Shock: 0.1g (1m/s²) Max.
- Humidity: (50%±10%)RH
- Local air pressure: (86~106)kPa
- Power supply: (1.5±0.0015)mADC

■ ENVIRONMENT CONDITION

- Shock: No change at 10gRMS,(20~2000)Hz
- Impact: 100g, 11ms
- Media compatibility: the gas or liquid which is compatible with construction material and Viton

■ SPECIFICATION

Item*	Min.	Typ.	Max.	Units
Linearity		±0.15	±0.25	%FS,BFSL
Repeatability		±0.05	±0.075	%FS
Hysteresis		±0.05	±0.075	%FS
Zero output		±1	±2	mV DC
FS output	70			mV DC
Zero thermal error		±0.75	±1.0	%FS, @25 °C
FS thermal error		±0.75	±1.0	%FS, @25 °C
Compensated temp. range	0~50			°C
Working temp. range	-40~125			°C
Storage temp. range	-40~125			°C
Long-term stability		±0.2	±0.3	%FS/year

*Testing at basic condition,G: Gauge; A: Absolute; S: Sealed gauge

** OBG, FS output ≥45mV

OAG, FS output ≥60mV

02A, 03A, 02GY, 03GY, FS output ≥45mV

07A, 08A, 07GY, 08GY, FS output ≥60mV

■ CONSTRUCTION PERFORMANCE

- Diaphragm: stainless steel 316L,Titanium (MPM280Ti),Tantalum (MPM280TH, MPM280TS), Hastelloy C(MPM280HH)
- Housing: stainless steel 316L,Titanium (MPM280Ti) Hastelloy C(MPM280TH, MPM280HH)
- Pressure leading tube: stainless steel 316L
- Pin: Kovar
- O-ring: Viton
- Net weight: ~23g (general type, MPM280TH, MPM280TS and MPM280HH) /~50g(flush diaphragm) ~125g(assembled type) /~13.5g (MPM 280Ti)

■ ELECTRICAL PERFORMANCE

- Power supply: ≤2.0mA DC;≤10V DC
- Electrical connection: Ø0.5mm Kovar pin or 100mm silicon rubber flexible wires
- Common mode voltage output: 50% of input (typ.)
Input impedance: 3kΩ~8kΩ
- Output impedance: 3.5kΩ~6kΩ
- Response (10%~90%): <1ms
- Insulation resistor: 100MΩ, 100V DC
- Overpressure: 1.5 times FS

OUTLINE CONSTRUCTION

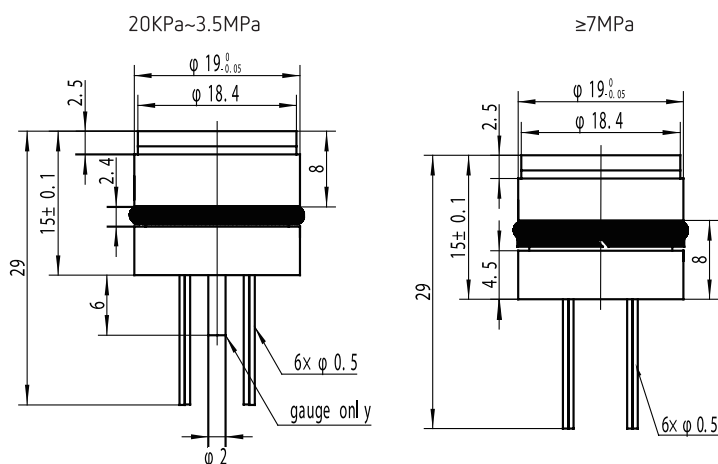

For option 0 or null, suggested installation dimension is $\Phi 19^{+0.05}_{+0.02}$ mm

20KPa ≤ P ≤ 2MPa
3.5MPa ≤ P ≤ 70MPa

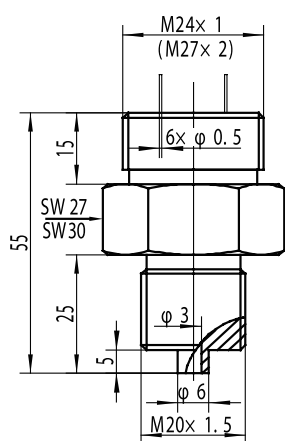

Option H1/H2

20KPa ≤ P ≤ 2MPa
3.5MPa ≤ P ≤ 35MPa

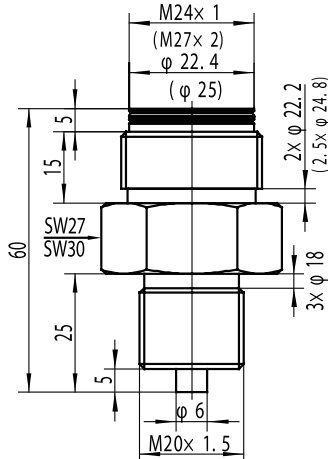

Option H3/H4

100KPa ≤ P ≤ 35MPa

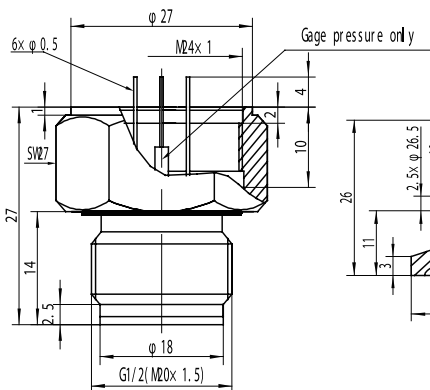

Option PC1/PC2 / PC3

100KPa ≤ P ≤ 3.5MPa

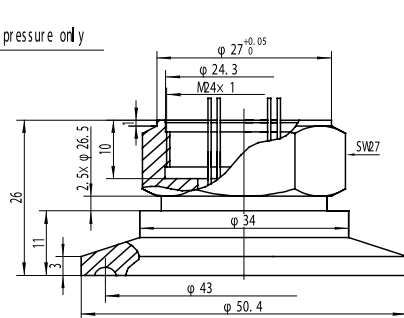

Option PD1

ELECTRICAL CONNECTION

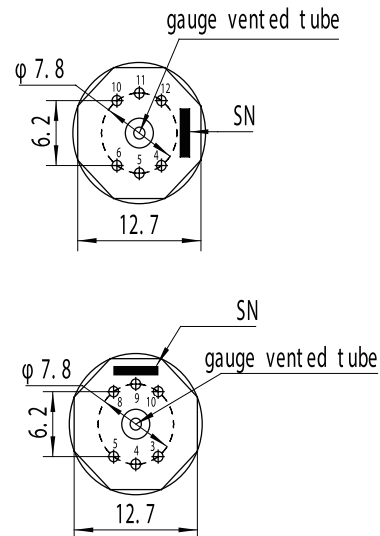

Pin	Definition	Wire color
4	+OUT	Red
5	+IN	Black
6	-IN	Yellow / White
10	-OUT	Blue
Other pins are useless		

Pin	Definition	Wire color
4	+OUT	Red
5	-IN	Yellow / White
8	+IN	Black
9	-OUT	Blue
Other pins are useless		

Pin	Definition	Wire color
4	-OUT	Blue
5	-IN	Yellow / White
8	+IN	Black
9	+OUT	Red
Other pins are useless		

Notes

The actual electrical connection method, please check the parameter label enclosed with products.



ORDERING GUIDE

MPM280 (TH/TS/HH/Ti)*		Piezoresistive OEM Pressure Sensor					
code	range	Ref.	Range code	range	Ref.		
0B	0kPa~20kPa	G	12	0MPa~2MPa	G.A		
0A	0kPa~35kPa	G.A	13	0MPa~3.5MPa	G.S.A		
02	0kPa~70kPa	G.A	14	0MPa~7MPa	S.A		
03	0kPa~100kPa	G.A	15	0MPa~10MPa	S.A		
07	0kPa~200kPa	G.A	17	0MPa~20MPa	S.A		
08	0kPa~350kPa	G.A	18	0MPa~35MPa	S.A		
09	0kPa~700kPa	G.A	19	0MPa~70MPa	S.A		
10	0kPa~1000kPa	G.A	20	0MPa~100MPa	S.A		
Code		Pressure type					
G		Gauge					
A		Absolute					
S		Sealed gauge					
Code**		Pressure connection	Installation				
0 or null		O-ring					
H1		M24x1 male(assembled, P≤2MPa)	C1~C11 are available for pressure connections for both assembled and welded type				
H2		M27x2 male (assembled, P≤70MPa)					
H3		M24x1 male(welded, P≤2MPa)					
H4		M27x2 male (welded, P≤35MPa)					
C1		M20x1.5 maleface type seal	Pressure connection options for assembled or welded type				
C2		G1/4 male					
C3		G1/2 male					
C4		G1/4 female					
C5		M20x1.5male waterline seal					
C6		1/4NPT male					
C8		1/4NPT female					
C10		1/2NPT male					
C11		1/2NPTfemale					
C15		R1/4 male					
C31		R1/2 male					
PC ₁		Flush diaphragm M20x1.5 male	Top: M24x1 female				
PC ₂		Flush diaphragm R1/2 male					
PC ₃		Flush diaphragm G1/2 male					
PD ₁		DN25 clamp					
Code		Compensation					
L		Laser trimming					
M		Outer compensated resistor (providing resistor value)					
Code		Electrical connection					
1		Kovar pin(default)					
2***		100mm silicon rubber flexible wires					
Code		Special measurement					
Y		Gauge sensor to measure vacuum(0kPa~ -100kPa)					
MPM280	09	G	0	L	1	Y	The whole spec



■ ORDERING NOTES

1. We suggest you to use Floating construction when you install the sensor to prevent affecting sensor stability;
2. Please pay attention to protect sensor isolated diaphragm and ceramic compensated board, to avoid damaging sensor or affecting the performance;
3. Temperature resistant range of standard Viton O-ring of sensor is -20°C ~ 250°C . When working temperature is lower than -20°C , or sensor is applied in critical environment, please contact us.

* For sensor with tantalum diaphragm and hastelloy housing, the model shall be MPM280TH, For sensor with tantalum diaphragm and 316L housing, the model shall be MPM280TS, for all Hastelloy C material sensor (Hastelloy C diaphragm and Hastelloy C housing), the model shall be MPM280HH, for all titanium material sensor (titanium diaphragm and titanium housing), the model shall be MPM280Ti.

**For assembled and welded type, please choose the top connection and pressure connection at the same time, eg. H1C2. For other customized options not shown in the order guide, please contact us.

***For the sensor with "flexible silicone wire", the electric connection on the parameter label shall be default code "1", wire length shall be made clear on the contract.