



bar **MPM4780**
Intelligent Pressure Transmitter

MPM4780 Intelligent Pressure Transmitter is a highly integrated measurement product with high stability. It uses intelligent processing circuit, the most advanced design and manufacturer technology of piezoresistive pressure transmitter, and is available for pressure signal and temperature signal output that in accordance with standard MODBUS-RTU protocol. Featuring integrated design, standard digital output, great compatibility, small size, high accuracy, light weight and wide pressure range, it can be applied in many fields which involve high accuracy required measurement of fluids. It also can take replace of pressure transmitters in the form of MODBUS-RTU protocol output by providing pressure type measurement for users.



MICROSENSOR

AUTHORIZED DISTRIBUTOR

FEATURES

- RS485 communication interface, Standard MODBUS-RTU Protocol output
- Netting available
- Short circuit protection and reverse polarity protection
- Full stainless steel construction, compact size, light weight
- Good output consistency and replaceability
- Available for calibration and parameter change on site through matched software of computer

SPECIFICATION

Range	-1bar...0bar~0.1bar...1000bar
Over pressure	1.5 times FS / 1100bar (min. value is valid)
Pressure type	Gauge/ Absolute/ Sealed gauge
Power Supply	9V~28V DC
Output signal	RS485 Interface(MODBUS-RTU protocol)
Accuracy	±0.5%FS
Thermal drift	±0.04%FS/°C (≤1bar); ±0.03%FS/°C (>1bar)
Measurement Error	±2°C (For "temperature & pressure type" only)
Application Temp.	-30°C ~ 80°C ; -10°C ~ 70°C (cable)
Storage Temp.	- 40°C ~ 120°C ; -20°C ~ 85°C (cable)
Insulation	100V, 100M
Stability	±0.3%FS/YEAR
Shock	20g, 25Hz~2000Hz
Impact	100g, 11ms
Protection	IP65(B ₁ , B ₂); IP63(B ₃)
Weight	~160g
Housing	Stainless steel 304
Diaphragm	Stainless steel 316L
O- Ring	Viton

Notes: 1. Shrinking range is 1/5 basic range, no range extension;
2. For special temperature requirement, please feel free to contact our company.



OUTLINE CONSTRUCTION (Unit: mm)

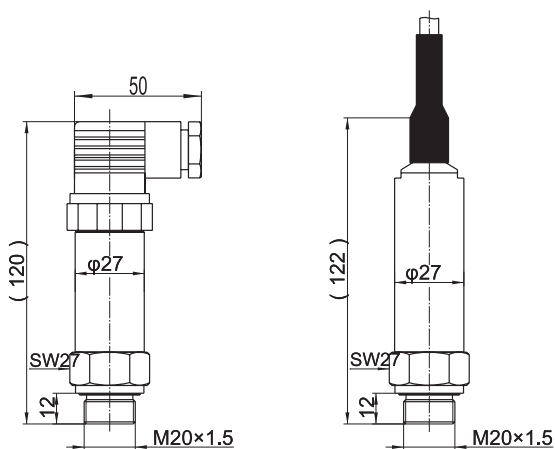

B₁ 4-pin Plug

B₂ Cable

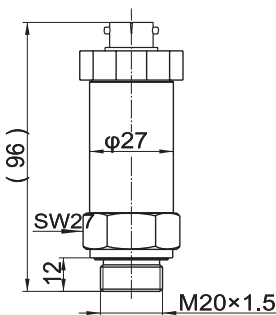

B₃ 7-pin Plug

COMMUNICATION CONNECTION

Transmitter connecting the outside by plug or cable:

Function	Inner plug pin color	Outer Electrical Connection		
		4-pin plug	Wire Color	7-pin plug
+V	1 (Black)	1	Black	1
-V	2 (Red)	2	Red	2
RS485B	4 (White)	⊕	White	5
RS485A	5 (Yellow)	3	Yellow	4

Electrical connection for transmitter with RS485 interface (MODBUS Protocol):

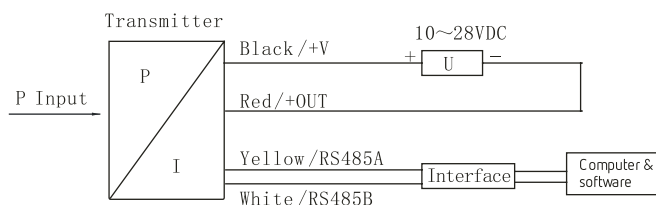

ASSISTANT SOFTWARE

MPM4780 Transmitter Software

RS232/485 Conversion module is used to communicate with RS485 interface transmitter, available for real time pressure/temperature display and calibration on site. Some parameters calibration was done before being transported at factory, so users do not have to modify them. When mistaken operations happen, users can push "Back to Factory Setting" to turn it to factory setting. Besides, the software keeps Data Record section, which allow users to set the record interval freely for recording and saving data, and the data can be saved in the forms of "*.Excel".

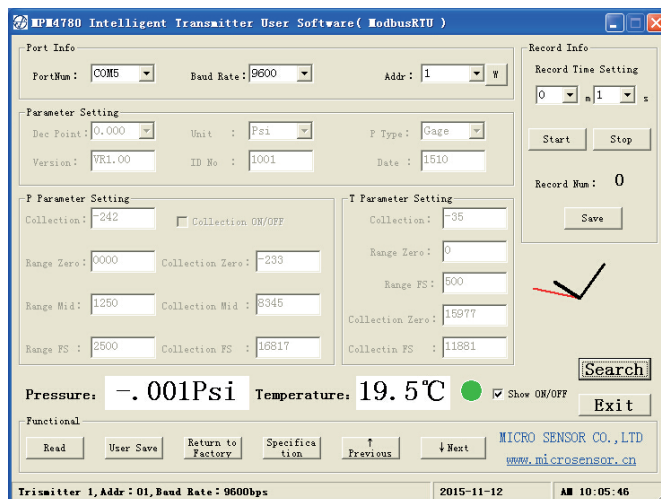



ORDER GUIDE

MPM4780		Intelligent Pressure Transmitter			
Range		Measure range: -1bar...0bar~0.1bar...1000bar			
[0~X]bar		X= actual measure range			
Code		Output Signal			
R ₈		RS485 interface, MODBUS communication protocol			
Code		Construction Material			
		Diaphragm	Pressure Port	Housing	
22		S.S.316L	S.S.	S.S.	
24		S.S.316L	S.S.316L	S.S.316L	
Code		Others			
B ₁		4-pin plug connection			
B ₂		Cable connection, default cable length: 1.5m			
B ₃		7-pin plug connection			
C ₁		M20 × 1.5 male, face type seal			
C ₃		G1/2 male			
C ₄		G1/4 female			
C ₅		M20 × 1.5 male, waterline seal			
Yc		MS200 water-proof connection box			
Yd		PD140 lightning-proof protection device			
G		Gauge			
S		Sealed Gauge			
A		Absolute			
MPM4780	[0 ~1]bar	R ₈	22	B ₁ C ₁ YdG	The Whole Spec.

NOTES

1. Please note transmitter type (Pressure/level) in the order;
2. There is no temperature measurement function for typical transmitter, if temperature measurement is needed, please note in order;
3. Please note in the order if the user needs zero pressure as negative pressure;
4. Please note the type of junction box if wiring box needed; If the user has no special requirement for cable, we provide default PVC cable;
5. If the user has special requirement, please feel free to contact our company.