



mm **P116**

**APPLICATION**

- Non-contacting inductive technology to eliminate wear
- Fully integrated electronics
- Travel set to customer's requirement
- Compact and easy to install
- High durability and reliability
- High accuracy and stability
- Sealing to IP67
- Frequency response of 10kHz
- Can be modified and supplied as drop in replacements for competitor products



The P116 linear sensor is designed to be fitted inside hydraulic or pneumatic cylinders allowing the external cylinder design to be unaffected. It is an extremely durable, high-accuracy device providing position feedback for applications where service life, environmental resistance and cost are important.

It is particularly suitable for OEMs where very competitive volume pricing and unmatched overall performance make it a very attractive option. The sensor has fully integrated electronics with a variety of voltage and current outputs so no need for any external signal conditioning.

Overall performance, repeatability and stability are outstanding over a wide temperature range. The sensor is compact and responsive along almost its entire probe length. Like all Positek® sensors each unit is supplied with the output calibrated to the exact travel required by the customer, which can be anything from 5mm up to a maximum of 600mm. It also has full EMC protection built in. The P116 is stainless steel with an inert fluoropolymer- sheathed probe with a stainless steel target tube.

Sealing is to IP67

The sensor is easy to install within cylinders and has a range of mechanical and electrical options. The P116 can also be modified to match other products that are currently on the market or where the cylinder has already been machined to a specific size. They have major advantages over LVDT's, such as compact stroke to length ratio, 10kHz frequency response. In addition they have no electrically wearing parts so don't suffer the problems associated with potentiometer based devices. Since there are no external electronics, it offers protection against accidental damage which can cause machinery downtime and increased costs.

**SPECIFICATIONS**

<b>Dimensions<sup>1</sup></b>	
Body diameter	Ø27 mm
Body Length	41.5 mm
Probe Length	calibrated travel + 28 mm (nom.)
Target Tube Length	calibrated travel + 30 mm
<b>Independent Linearity</b>	≤ ± 0.25% FSO @ 20°C - up to 600 mm
<b>Temperature Coefficients</b>	< ± 0.01%/°C Gain & < ± 0.01%FS/°C Offset
<b>Frequency Response</b>	> 10 kHz (-3dB)
<b>Resolution</b>	Infinite
<b>Noise</b>	< 0.02% FSO

05.2025 | version 0001

**SPECIFICATIONS (CONTINUED)**

<b>Environmental Temperature Limits</b>	
<b>Operating</b>	-40°C to +125°C standard -20°C to +85°C buffered
<b>Storage</b>	-40°C to +125°C
<b>Sealing</b>	IP67
<b>Hydraulic Pressure</b>	350Bar
<b>EMC Performance</b>	EN 61000-6-2, EN 61000-6-3
<b>Vibration</b>	IEC 68-2-6: 10 g
<b>Shock</b>	IEC 68-2-29: 40 g
<b>MTBF</b>	350,000 hrs 40°C Gf
<b>Drawing List<sup>2</sup></b>	
<b>P116-11</b> <b>TG24-11</b>	Sensor Outline Optional Target Tube Flange details

<sup>1</sup> For full mechanical details see drawings P116-11

<sup>2</sup> 3D models, step or .igs format, available on request

**HOW ALTHEN'S TECHNOLOGY ELIMINATES WEAR FOR LONGER LIFE**

Althen's Inductive technology is a major advance in displacement sensor design. Our displacement transducers have the simplicity of a potentiometer with the life of an LVDT/RVDT.

Our technology combines the best in fundamental inductive principles with advanced micro-electronic integrated circuit technology. An Althen sensor, based on simple inductive coils using Althen's ASIC control technology, directly measures absolute position giving a DC analogue output signal. Because there is no contact between moving electrical components, reliability is high and wear is eliminated for an exceptionally long life.

It also overcomes the drawbacks of LVDT technology – bulky coils, poor length-to-stroke ratio and the need for special magnetic materials, no requirement for separate signal conditioning.

We also offer a range of ATEX-qualified intrinsically-safe sensors.

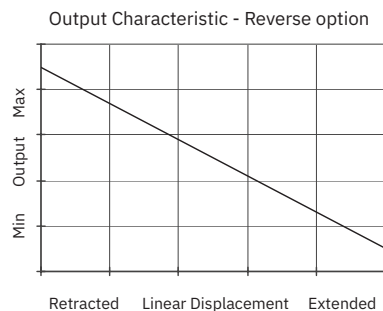
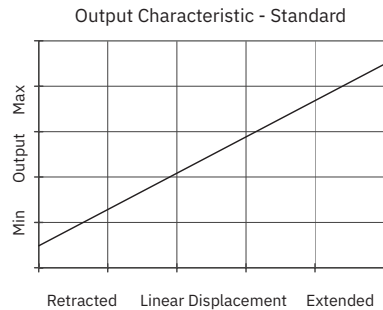

P116	a	b	c	d	e	f
	Displacement	Output	Lxx	Option	Option	Z-code

a Displacement		Value
Factory set to any length from 0-5 mm to 0-600 mm (e.g. 0- 254 mm)		254
b Output		
Supply $V_{dc}$ (tolerance)	Output	Code
+5V (4.5 - 5.5V)	0.5 - 4.5V (ratiometric with supply)	A
±15V nom. (±9 - 28V)	±5V	B
+24V nom. (13 - 28V)	4 - 20mA 3 wire Sink	F
+24V nom. (9 - 28V)	0.5 - 4.5V	G
+24V nom. (13 - 28V)	4 - 20mA (3 wire Source)	H
Supply Current: 'A' 10mA nominal, 12mA max. 'G' 12mA nominal, 15mA max. 'H' 32mA nominal, 35mA max.		
c Connections		Code
Cable gland† IP67		Lxx
Specify required cable length 'xx' in cm. e.g. L2000 specifies axial cable gland with 20 m of cable, 50 cm supplied as standard. †Nb: restricted cable pull strength.		

d Target Tube		Code
Stainless Steel 316 O.D.: 9.45 mm		R
Aluminium 6063 O.D.: 3/8"		S
See P100-12 Drawing for Typical Target Installation details.		
e Target Tube Mounting Flange		Code
None		U
Penny & Giles HLP100		Vxx
Temposonics (M4 fixing)		Wxx
Please specify flange position in mm. eg. W17.5 specifies a Tempo style flange fitted 17.5 mm from the front face		
Parker Hannifin		Xxx
See TG24-11 Drawing for Target Details.		
f Z-code (optional)		Code
Tighter Independent Linearity; $\leq \pm xx\%$ FSO @20°C $\leq \pm 0.1\%$ 0 - 10 mm min. to 0 - 450 mm		Z650

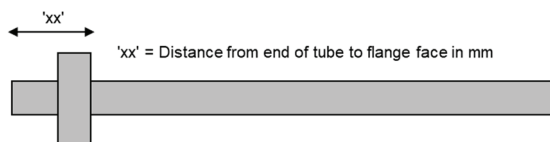

## INSTALLATION INFORMATION

Output Option	Output Description	Supply Voltage: $V_s$ (tolerance)	Load resistance: (include leads for 4 to 20mA O/Ps)
A	0.5 - 4.5V (ratiometric with supply)	+5V (4.5 - 5.5V)	$\geq 5k\Omega$
C	0.5 - 9.5V	+24V nom. (13 - 28V)	$\geq 5k\Omega$
G	0.5 - 4.5V	+24V nom. (9 - 28V)	$\geq 5k\Omega$
H	4 - 20mA 3 wire Source	+24V nom. (13 - 28V)	$\approx 0 - 300\Omega$ max. $\sim 1.2$ to 6V across 300 $\Omega$

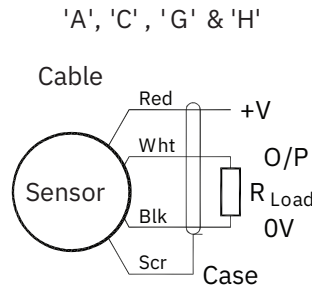

**MECHANICAL MOUNTING**

The sensor is intended for internal mounting in hydraulic or pneumatic cylinders. Retain with an M6 grub screw, see drawing P116-11 for details. Install the target tube using the flange provided or adhere directly into the piston rod, the end of the target tube can be proud or flush with the piston end face as required.

**OUTPUT CHARACTERISTIC**

Target position at start of normal travel is 21 mm from sensor body. The output increases as the target is moved away from the sensor body, the calibrated stroke is between 5 mm and 800 mm.

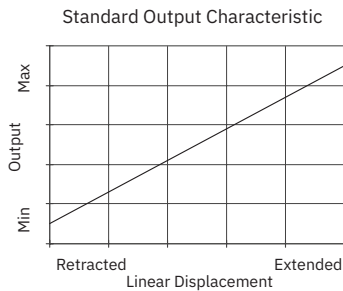

**INCORRECT CONNECTION PROTECTION LEVELS**

A	<b>Not protected</b> – the sensor is <b>not</b> protected against either reverse polarity or over-voltage. The risk of damage should be minimal where the supply current is limited to less than 50mA.
C & G	Supply leads diode protected. Output must not be taken outside 0 to 12V.
H	Supply and output lead diode protected. Do take output negative of 0 volts.

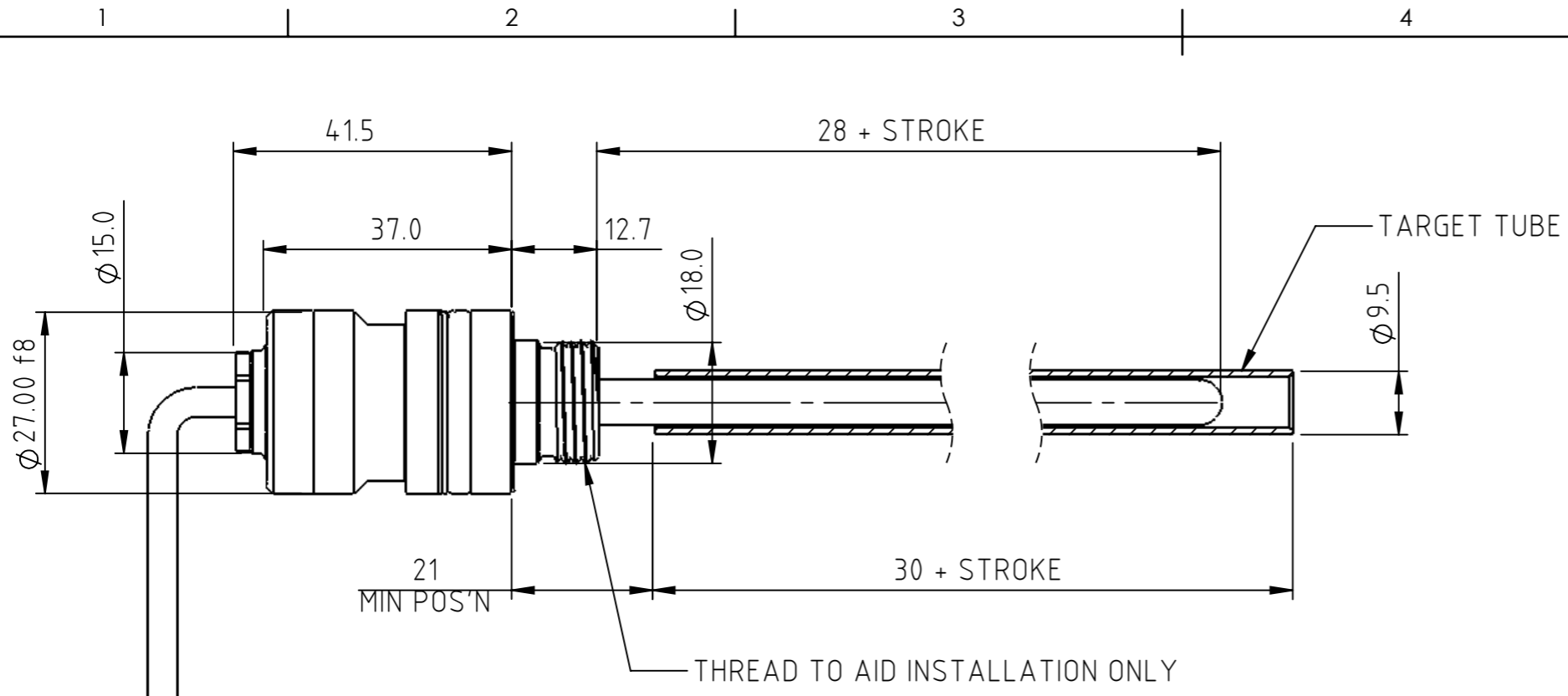

**ELECTRICAL OPTIONS/ SPECIFICATIONS**

OUTPUT	SUPPLY (NOM.)
'A' 0.5 - 4.5V RATIO METRIC	5V
'C' 0.5 - 9.5V	24V
'G' 0.5 - 4.5V	24V
SUPPLY CURRENT 12mA TYP. 20mA MAX.	
'H' 4 TO 20mA SOURCE§	24V
§ DRIVE 300Ω MAXIMUM TO 0V	

CONNECTIONS; CABLE 3-CORE  
+Ve RED  
0V BLACK  
-Ve -  
OUTPUT WHITE  
BODY SCREEN

CABLE; 0.2mm<sup>2</sup>, 0/A SCREEN, PUR JACKET. O/D; 3-CORE: Ø4mm

SUPPLIED WITH 50cm OR REQUIRED LENGTH IN cm. e.g. 'L50'  
CONNECTORS; MAXIMUM CONDUCTOR CROSS SECTION 0.25mm<sup>2</sup>

SENSOR IS MANUFACTURED TO A SPECIFIC LENGTH AND MEASUREMENT RANGE SPECIFIED BY THE CUTSOMER UP TO A MAXIMUM RANGE OF 600mm.

BODY MATERIAL:- STAINLESS STEEL.

TARGET TUBE OPTIONS:  
MATERIAL: OPTION 'R' - STAINLESS STEEL Ø9.45  
OPTION 'S' - ALUMINIUM 6063 Ø3/8" (9.2-9.8mm)

TARGET TUBE FLANGE OPTIONS: SEE DRAWING TG24-11  
TARGET TUBE MOUNTING ARRANGEMENTS: SEE DRAWING P100-12

SEALING: IP67 AS STANDARD  
(IP68 VERSION AVAILABLE ON REQUEST)

CABLE LENGTH SPECIFIED BY CUSTOMER IN cm

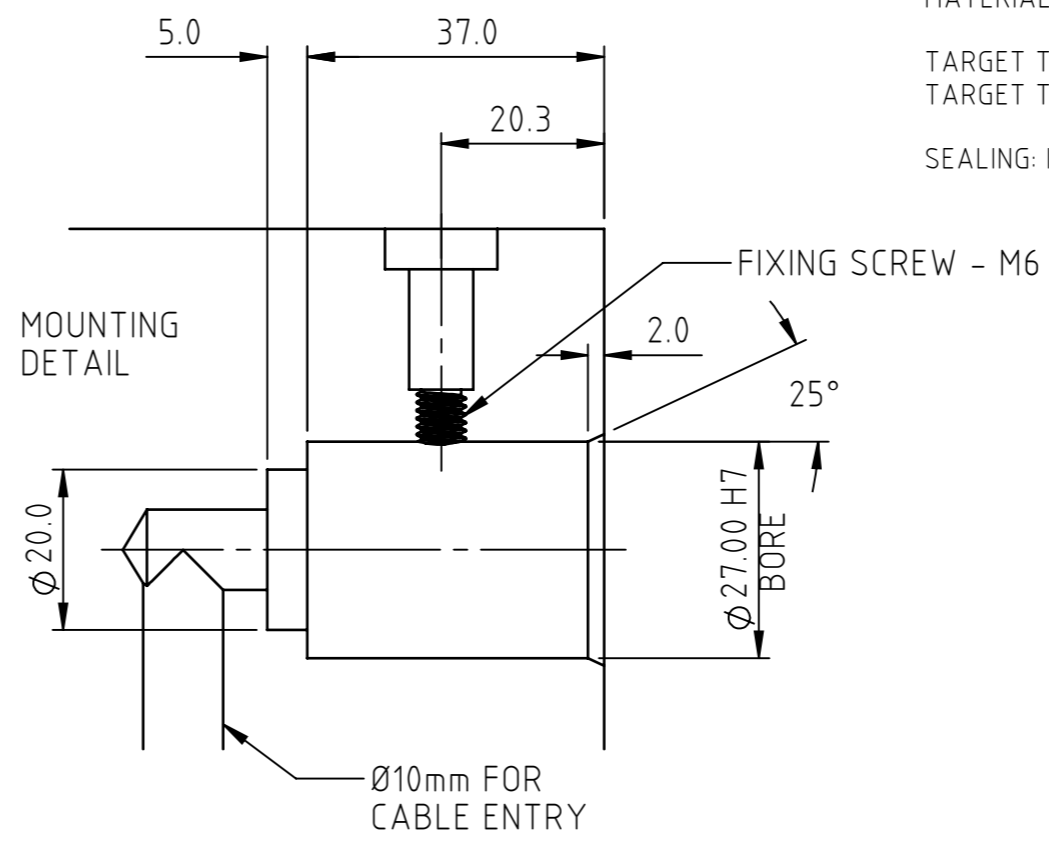

DRAWINGS NOT TO BE CHANGED WITHOUT REFERENCE TO THE CHANGE PROCEDURE.  
CHANGES TO PARTS USED IN INTRINSICALLY SAFE PRODUCT MUST BE APPROVED BY THE AUTHORISED PERSON.  
THIS IS AN UNCONTROLLED PRINT AND WILL NOT BE UPDATED.

REV	CHANGE HISTORY	DR'WN	DATE	CHK'D
A	FIRST RELEASE	ASC	08/09/2020	-



APPROVED BY <b>RDM</b>	REV <b>A</b>		X ±0.4 X.X ±0.2 X.XX ±0.1 DIMS mm
DESCRIPTION <b>LIPS P116 INTERNALLY MOUNTED CYLINDER SENSOR</b>			
SCALE <b>3:4</b>	DRAWING NUMBER <b>P116-11</b>		
<b>A4</b>	SHEET 1 OF 1		

TARGET TUBE OPTION NOTES:-

- SPECIFY TUBE MATERIAL; CODE:-  
'R' STAINLESS STEEL 316  $\phi$ 9.45.  
'S' ALUMINIUM 6063  $\phi$ 3/8" (9.2-9.8). NOTE! ONLY AVAILABLE WITH P100 OR P106 VERSIONS.
- SPECIFY FLANGE TYPE; CODE: 'U', 'Vx', 'Wx' OR 'Xx' ~ SEE DETAILS BELOW.
- SPECIFY DIMENSION 'x' (mm), NOT APPLICABLE CODE 'U' PLAIN TUBE.

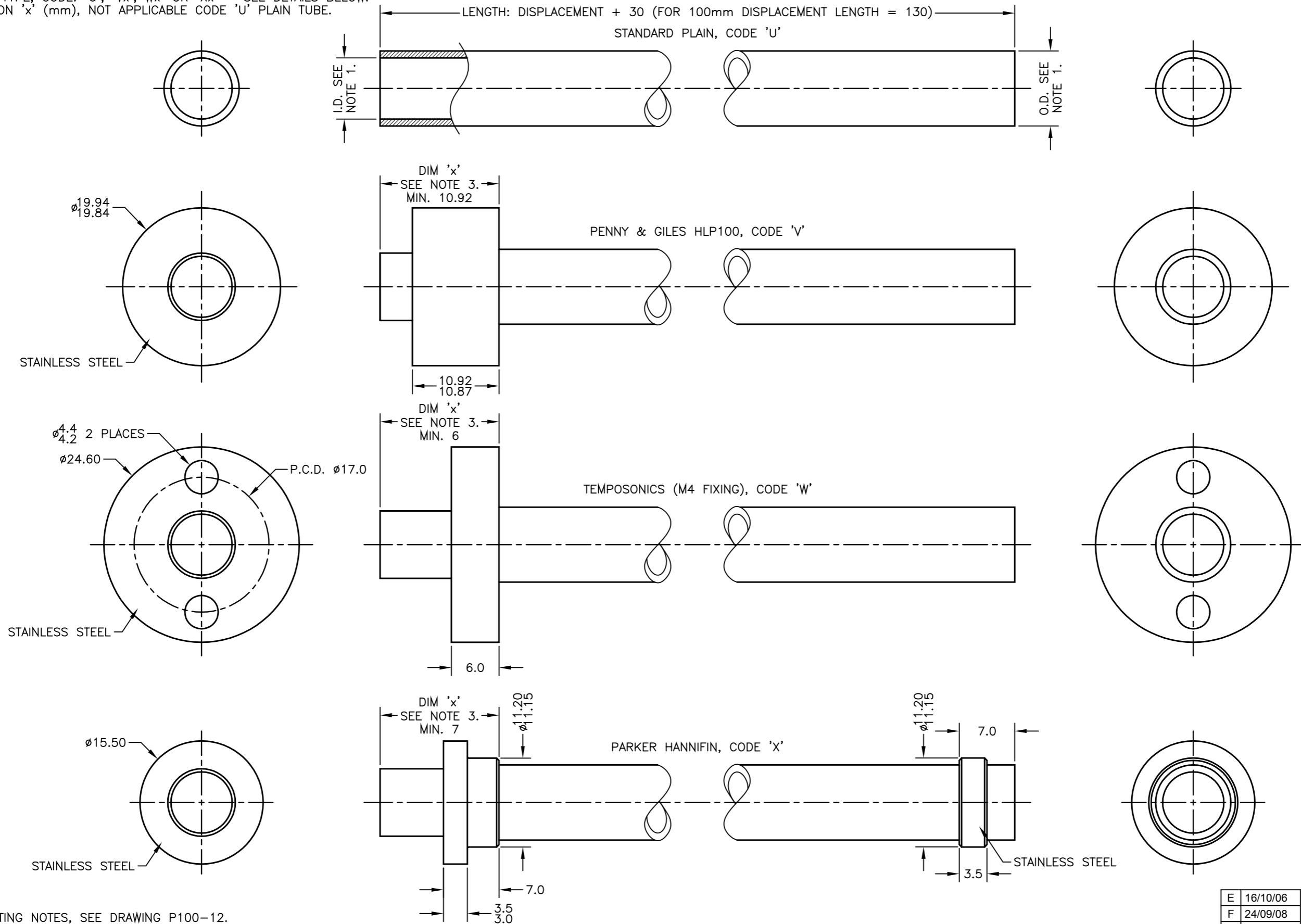

TARGET TUBE MOUNTING NOTES, SEE DRAWING P100-12.

E	MATERIAL OPTION REMOVED.	PDM
F	MAT'L OPTION REINSTATED RAN221.	PDM
G	X DIM FOR PH FLANGE SHOWN RAN225	RDS
H	9.45 WAS 9.5 RAN396	RDS
J	REDRAWN, PH FLANGE ROTATED RAN507.	PDM
K	NOTE 1 AMENDED ~ RAN1114.	PDM
L	'x' WAS 'n' ~ RAN1309	PDM

DRAWINGS NOT TO BE CHANGED WITHOUT REFERENCE TO THE CHANGE PROCEDURE.  
CHANGES TO PARTS USED IN INTRINSICALLY SAFE PRODUCT MUST BE APPROVED  
BY THE AUTHORISED PERSON  
THIS IS AN UNCONTROLLED PRINT AND WILL NOT BE UPDATED.

E	16/10/06		CHECKED BY	X	$\pm 0.4$
F	24/09/08		RDM	X.X	$\pm 0.2$
G	13/11/08			X.XX	$\pm 0.1$
H	11/12/12			DIMS	mm
J	23/07/14				
DESCRIPTION		TARGET TUBE AND FLANGE			
K		30/11/16			
L		08/11/22			
SCALE		DRAWING NUMBER			
5mm		TG24-11			
		REV		L	
		SHEET 1 OF 1			