



PC420A SERIES

RMS and peak acceleration loop powered sensors

PC420A series sensors provide a 4-20 mA output proportional to vibration, allowing for continuous trending of overall machine vibration. This trend data alerts users to changing machine conditions and helps guide maintenance in prioritizing the need for service. The choice of RMS or peak output allows you to choose the sensor that best fits your requirements.



Table 1: PC420Ax-yy model selection guide

x (4-20 mA output type)	yy (4-20 mA full scale)
R = RMS output, acceleration	05 = 5 g
P = calculated peak output, acceleration	10 = 10 g
	20 = 20 g
	50 = 50 g

Note: True peak output is available on PC420ATP series models.

Key features

- True RMS or calculated peak output
- Easily integrated into existing process control systems
- Intrinsically safe certified and explosion-proof models available
- True peak output available
- Manufactured in an approved ISO 9001 facility

CERTIFICATIONS



Note: Due to continuous process improvement, specifications are subject to change without notice. This document is cleared for public release.



SPECIFICATIONS

Full scale, 20 mA, ±5%		see Table 1 on page 1
Frequency response:	± 10% ± 3 dB	10 Hz - 1.0 kHz 1.0 Hz - 2.0 kHz
Repeatability		± 2%
Transverse sensitivity, max		5%
Power requirements, 2-wire loop power:		
Voltage at sensor terminals		12 - 30 VDC
Loop resistance¹ at 24 VDC, max		700 Ω
Turn on time, 4-20 mA loop		< 30 seconds
Grounding		case isolated, internally shielded
Operating temperature range		-40° to +105° C
Vibration limit		250 g peak
Shock limit		2,500 g peak
Sealing		hermetic
Sensing element design		PZT, shear
Weight		160 grams
Case material		stainless steel
Mounting		1/4-28 tapped hole
Output connector		2 pin, MIL-C-5015 style
Mating connector		R6 type
Recommended cabling		J9T2A

Accessories supplied: SF6 mounting stud (metric mounting available); calibration data (level 2)

Connections	
Function	Connector pin
loop positive (+)	A
loop negative (-)	B
ground	shell

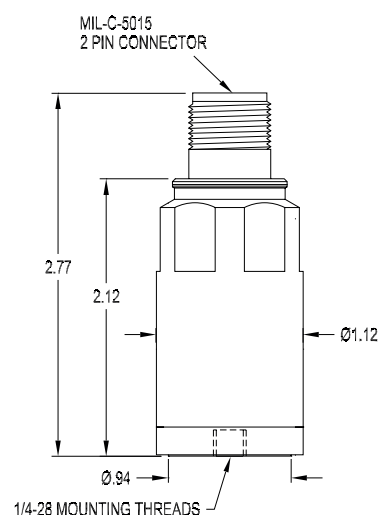

Notes: ¹ Maximum loop resistance (R_L) can be calculated by:

$$R_L = \frac{V_{DC\ power} - 10\ V}{20\ mA}$$

DC supply voltage	R_L (max resistance) ²	R_L (minimum wattage capability) ³
12 VDC	100 Ω	1/8 watt
20 VDC	500 Ω	1/4 watt
24 VDC	700 Ω	1/2 watt
26 VDC	800 Ω	1/2 watt
30 VDC	1,000 Ω	1/2 watt

² Lower resistance is allowed, greater than 10 Ω recommended.

³ Minimum R_L wattage determined by: $(0.0004 \times R_L)$.

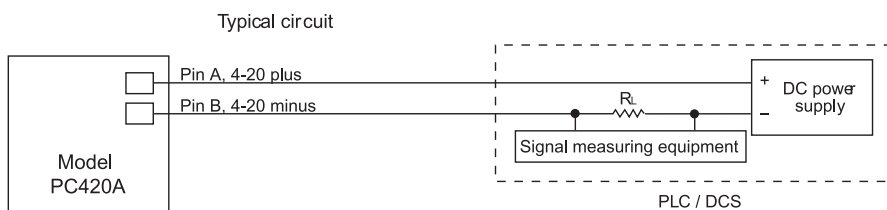

Note: Due to continuous process improvement, specifications are subject to change without notice. This document is cleared for public release.