



bar

PR3920 PROTRAN® Subsea Differential Pressure Transmitter

SPECIFICATIONS

- Silicon-on-Sapphire sensor technology for outstanding performance
- Standard sensing range 0-50 bar DP
- 690 bar line pressure
- 1,200 bar secondary containment
- Submersion to 3,000 metres sea level
- High accuracy option
- NACE corrosion resistance
- Hyperbaric testing and Environmental Stress Screening (ESS Testing)
- ATEX/IECEX option available (includes M1 for mining applications)

The PR3920 differential pressure transmitter provides very accurate low pressure wet-wet differential pressure measurement on extremely high line pressure sources. Designed for permanent installation in very demanding subsea applications the housing is completely sealed to resist 300 bar external pressure. Intended for submersion in pressurised dielectric oil with seawater for monitoring of subsea well control valves or hydraulic pressure measurement.

The unique Silicon-on-Sapphire sensor technology provides outstanding performance and gives excellent stability over a wide temperature range. The advanced sensor design consists of a piezoresistive silicon strain gauge circuit, which is epitaxially grown onto the surface of a sapphire diaphragm to form a single crystalline structure. The sapphire sensor element is then molecularly bonded to a titanium alloy sub-diaphragm. This enables the sensor to endure higher over- pressures and provides superb corrosion resistance. The sensor exhibits virtually no hysteresis and excellent long-term stability. With Dimensions (in mm) outstanding insulation properties, the sapphire substrate allows the sensor to operate over a very wide temperature range without loss of performance.

The PR3920 pressure transmitter provides surface mounting with a stainless steel mounting plate and dual redundant

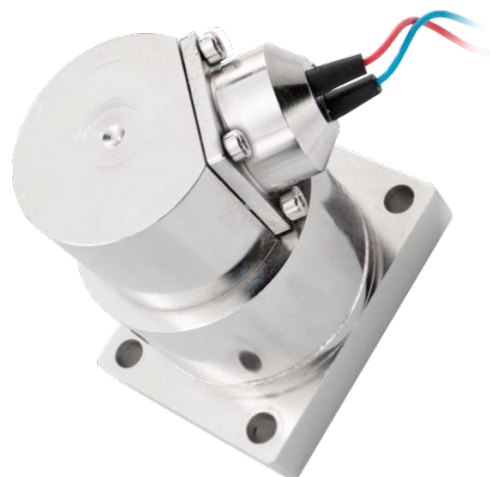

o-ring face seals. Both the high and low pressure ports can withstand 1,000bar overpressure with no damage or loss of performance. The titanium alloy wetted parts provide conformance to NACE corrosion resistance requirements. Electrical connection is via a heavy duty PTFE cable with optional angle of orientation. Output signal is a 4-20 mA, 2 wire current loop which can be powered from and external 10-36 Vdc supply. Application includes control of chemical injection for sub-sea wells for oil and gas extraction.

An optional ATEX and IECEX approved version of this product is available for explosion protection for flammable gases (zone 0), dusts (zone 20) and mining areas (group I M1).

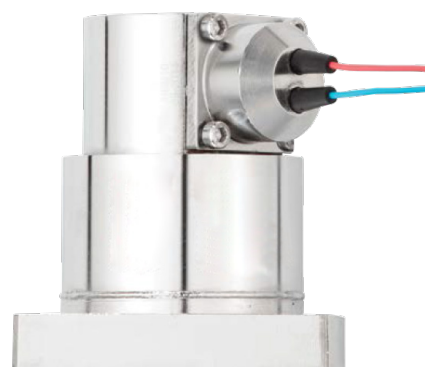



DIMENSIONS (in mm)

ELECTRICAL CONNECTION

Colour	Function
Red	Supply (10-36Vdc)
Blue	Signal (4-20mA)

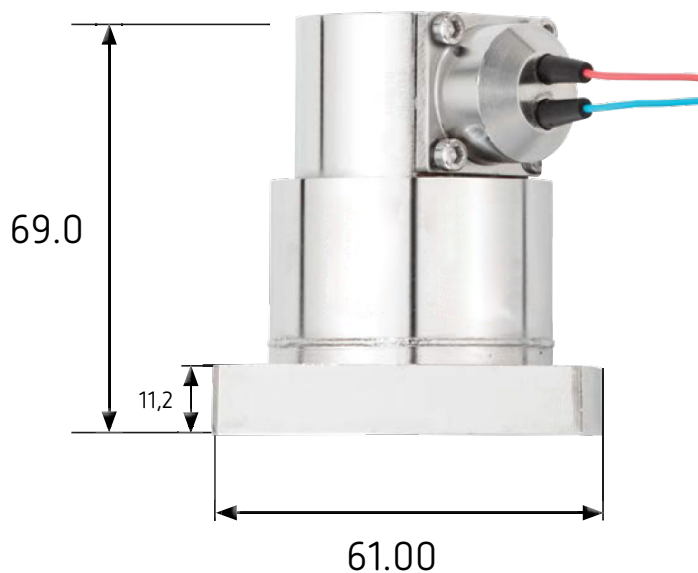



TECHNICAL DATA

Type	PR3920
Sensor Technology:	Silicon-on-Sapphire (SoS)
Output Signal:	4-20 mA (2 wire)
Supply Voltage:	10-36 VDC
Pressure Reference:	Differential Sealed Gauge
Protection of Supply Voltage:	Protected against supply voltage reversal up to 50 V
Differential Pressure Range:	0-750psi (51 barDP)
Overpressure Safety:	1.5x maximum static line pressure for all ranges
Secondary Pressure Containment:	1,200 bar max
Common Mode (Static line pressure):	To both ports simultaneously 690bar with less than 1%FS change on output signal.
Load Driving Capability:	4 – 20 mA: $RL < [UB - 10 V] / 20 \text{ mA}$; (e.g. with supply voltage (UB) of 36V, max. load (RL) is 1300 Ω)
Accuracy NLHR:	$\leq \pm 0.25 \%$ of span BFSL
Zero Offset and Span Tolerance:	$\pm 0.20 \text{ mA}$
Operating Ambient Temperature:	-10°C to +70°C (+14 °F to +158 °F)
Operating Media Temperature:	-10°C to +70°C (+14 °F to +158 °F)
Storage Temperature:	+5 °C to +40 °C (+41 °F to +104°F) Recommended Best Practice
Temperature Effects:	$\pm 3.0\%$ FS total error band for -20°C – +70°C. Typical thermal zero and span coefficients $\pm 0.05\%$ FS/ °C
ATEX/IECEx Approval Option:	Ex II 1 G Ex ia IIC T4 Ga (zone 0) Ex II 1 D Ex ia IIIC T135°C Da (zone 20) Ex I M 1 Ex ia I Ma (group 1 M1)
ATEX/IECEx Safety Values:	U _i = 28 V I _i = 119 mA P _i = 0.65 W L _i = 0.1 μH C _i = 74 nF Temperature Range = -20°C – +70°C Max. cable length = 45 m
Electromagnetic Compatibility:	Emissions: EN61000-6-4; Immunity: EN61000-6-2; Certification: CE Marked
Insulation Resistance:	> 1G Ω @ 50 VDC
Response time 10-90 %:	1 mS
Operating Environment:	Sealed for immersion in pressurised dielectric fluid up to 300bar and for short periods in seawater.
Wetted Parts:	SAE 316 stainless steel and titanium alloy
Pressure Media:	All fluids compatible with SAE 316 stainless steel and titanium alloy
Corrosion Resistance:	NACE compliant materials
Pressure Connection:	Face sealing mounting plate with dual redundant elastomeric O ring seals on both pressure ports.
Electrical Connection:	Raychem wire (optional cable outlet orientation available on request)
Net. Weight (Kg):	Subject to specification