



## QUICKSTART GUIDE, SAFETY, AND WARRANTY INDUSTRIAL NODE

The Industrial Node is a wireless batteryoperated sensor device for condition monitoring and predictive maintenance. It measures tri-axial vibration and surface temperature of rotating equipment, such as pumps, motors and compressors. Abnormal machine vibrations or high temperatures may give early signs of failure due component imbalance, misalignment, wear or improper use of equipment.

The Industrial Node operates in a mesh network transmitting sensor values directly or via other nodes to a gateway, such as Gateway. Typically, the data is sent from the gateway to a cloud backend for storage and further analysis.

Once the node is switched on, it starts automatically to measure and transmit data at pre-configured intervals. Depending on configuration Node can send raw vibration data and/or pre-calculated values, such as RMS velocity, Fast Fourier transform (FFT) and Kurtosis, to the cloud via the gateway.



### KEYS AND PARTS

- A. Status light
- B. Orientation notch
- C. Power button
- D. NFC tag
- E. M8 bolt
- F. Nut adapter\*
- G. Magnetic epoxy mount adapter\*
- H. Glue mount adapter\*

\* Note that adapters F, G, and H are not included in standard sales box.

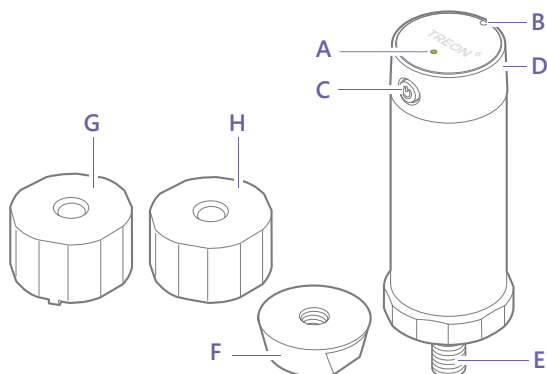

### 1 / MOUNTING THE NODE

When mounting the sensor to a monitored equipment, it is important to consider the location of the sensor and the contact between the sensor and the equipment. Best location to attach the sensor depends on the machine and the monitored vibration source.

For best measurement quality, the contact surface in the machine should be completely flat (within 1 mil), smooth (surface texture no greater than 32 microinches) and larger than the base of the node. It's recommended that nodes are mounted via a drilled and tapped hole directly to the machine housing.

In cases where the surface of the machine is curved or uneven, epoxy must be used between the machine surface and the node. Screwing the node to curved surface may lead to the node bolt twisting and permanent damage to the device.



**1 / CASE 1 - ATTACH NODE DIRECTLY TO MACHINE SURFACE**

Direct attachment between the Industrial Node and machine surface minimizes the vibration transmission route for best measurement quality. It requires a flat surface of 32mm diameter and hole for M8 bolt with 18.5mm of threading.

1. Clean the machine surface and apply silicon grease on it.
2. Apply service removable thread lock to the sensor bolt.
3. Insert the bolt into a M8 hole in the machine.
4. Screw the node with 30mm torque wrench to 8 newton meters torque.

**1 / CASE 2 - ATTACH NODE WITH NUT ADAPTER**

Using a nut adapter enables attaching the Industrial Node to a spot with less available space in diameter, shorter M8 opening with less threading and with additional epoxy to uneven surface. It requires a nut adapter, flat surface of 25mm diameter, hole for M8 bolt with 9.5mm of threading and optional epoxy.

1. Clean the surfaces between node and adapter and apply silicon grease on it.
2. Screw the adapter nut to the sensor bolt.
3. Tighten the nut to 8Nm torque.

**Without epoxy**

4. Clean the machine surface and apply silicon grease on it.
5. Apply service removable thread lock to the sensor bolt.
6. Insert the bolt into a M8 hole in the machine.
7. Screw the node with 22mm torque wrench to 8 newton meters torque.

**With epoxy**

4. Apply Epoxy to nut adapter surface.
5. Insert the bolt into a M8 hole in the machine.
6. Hand tighten the sensor.
7. Let the epoxy harden.

**1 / CASE 3 - ATTACH NODE WITH EPOXY OR GLUE MOUNT ADAPTER**

Using epoxy or glue mount adapter enables attaching Industrial Node without an opening for a bolt. With epoxy mount adapter the Industrial Node can also be attached to slightly uneven surface while glue mount adapter requires an even surface. Required surface diameter is 32mm.

1. Clean the surfaces between node and adapter and apply silicon grease on it.
2. Screw the mount adapter to the sensor bolt.
3. Tighten the nut to 8Nm torque.
4. Apply epoxy or glue to adapter surface.
5. Place the node to the correct position on the machine.
6. Let the epoxy or glue harden.

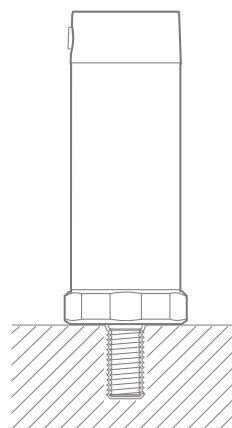

Case 1

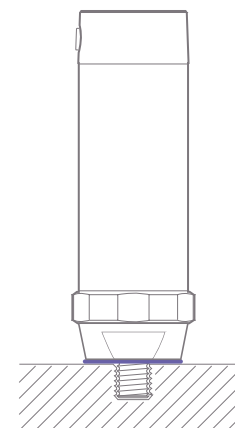

Case 2

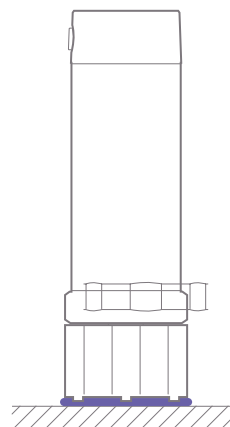

Case 3

## ■ ALIGNING THE NODE

For accurate interpretation of the measurement data, the centerline of the node is often aligned with the shaft of the rotating machine. This can be done by manually aligning the node with the shaft.

Manual alignment requires using the epoxy or glue mount adapter. After applying the fixative and hand tightening the sensor to the machine, align the node axis directly toward drive or nondrive end of monitored machine. Turn the node only clockwise.

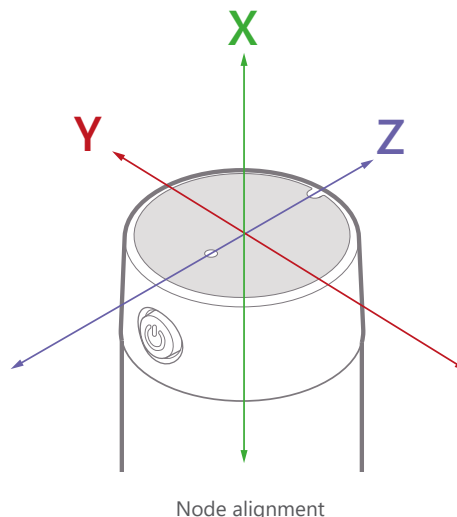

## ■ SWITCH ON THE NODE

Press and hold the power button until the status light turns green. If you want to switch off the node, press the power button until the status light turns red.

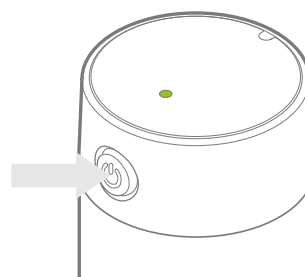

## ■ 2 / CHECK THE CONNECTION

To see if the node is connected to the gateway:

1. Press the power button briefly. The status light turns green and goes off.



2. If the status light then turns green again, the node is connected.

**CONNECTED**

If the status light turns red for 5 seconds, the node is not yet connected.

**NOT CONNECTED**

In case the node is not connected, the Gateway has been powered on and the node has had time to establish the connection, the node may be too far from the gateway or surroundings are blocking the radio connection. In either case, the gateway needs to be moved closer to the node or an additional routing node can be added between the node and the gateway to help routing the data.

## ■ 3 / READ THE NODE ID

The identification number of the node is printed on the sticker attached to the node, and it can be as well read from the QR code.

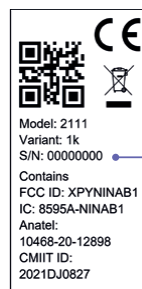

Identification number

You can also use a NFC reader, such as an NFC-enabled mobile phone to read the identification number: switch on NFC on the reader and touch the top of the node with the reader.

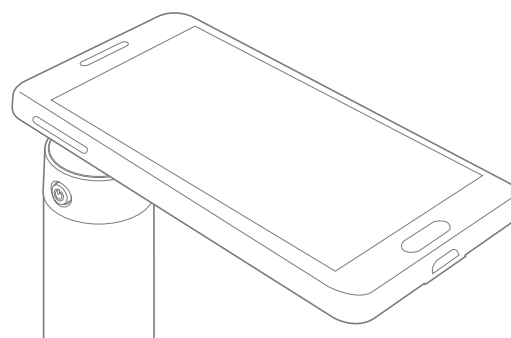



## ■ PRODUCT INFO

### Important

For important info on the safe use of your device, read the Safety Guide.

**Operating frequencies:** 2400MHz - 2483.5MHz

**Maximum power:** +4 dBm

**Operating temperature range:** -40 - +85°C

### Battery

Battery type: 3.6V A lithium thionyl chloride (LI-SOCI<sub>2</sub>) bobbin cell primary battery.

**The battery is non-removable. If the battery wears out, replace the node.**

## ■ SUPPLIER'S DECLARATION OF CONFORMITY

**FCC Compliance Statement** (for products subject to Part 15) This device complies with Part 15 of the FCC Rules. Operation is subject to the following two conditions:

- (1) This device may not cause harmful interference, and
- (2) This device must accept any interference received, including interference that may cause undesired operation.

## ■ EU DECLARATION OF CONFORMITY

 The industrial node complies with the policy 2014/53/EU

## ■ SAFETY GUIDE AND WARRANTY

### Introduction

Read these simple guidelines. Not following them may be dangerous or against local laws and regulations. For further information visit:

<https://www.althensensors.com/contact/>

### Care and maintenance

Handle your device with care. The following suggestions help you keep your device operational.

- Do not open the device other than as instructed in the user guide.
- Unauthorized modifications may damage the device and violate regulations governing radio devices.
- Do not drop, knock, or shake the device. Rough handling can break it.
- Only use a soft, clean, dry cloth to clean the surface of the device. Do not clean the device with solvents, toxic chemicals or strong detergents as they may damage your device and void the warranty.
- Do not paint the device. Paint can prevent proper operation.
- The node is dust and splash proof. However, it is not recommended to immerse it in water.

### Safety distance

Safety distance 150 mm from the magnetic mount adapter surface must be kept due to high strength magnets.

### Damage

If the device is damaged contact support <https://www.althensensors.com/contact/>. Only qualified personnel may repair this device.

### Small children

Your device is not a toy. It may contain small parts. Keep them out of the reach of small children.

### Interference with medical devices

The device may emit radio waves, which could affect the operation of nearby electronics, including cardiac pacemakers, hearing aids and defibrillators. If you have a pacemaker or other implanted medical device, do not use the device without first consulting your doctor or the manufac-



turer of your medical device. Maintain a safe distance between the device and your medical devices and stop using the device if you observe a persistent interference with your medical device.

### Storage

Always store and use the device with covers attached. Device storage temperature is +0 - +30°C.

### Recycle

Check the local regulations for proper disposal of electronic products.

The Directive on Waste Electrical and Electronic Equipment (WEEE), which entered into force as European law on 13th February 2003, resulted in a major change in the treatment of electrical equipment at end-of-life. The purpose of this Directive is, as a first priority, the prevention of WEEE, and in addition, to promote the reuse, recycling and other forms of recovery of such wastes so as to reduce disposal.



The crossed-out wheellie-bin symbol on your product, battery, literature, or packaging reminds you that all electrical and electronic products and batteries must be taken to separate collection at the end of their working life. Do not dispose of these products as unsorted municipal waste: take them for recycling. For info on your nearest recycling point, check with your local waste authority.

### WARRANTY

The Limited Warranty document can be obtained at the following internet address:

<https://www.althensensors.com/contact/>