



USER MANUAL FDRF656 SERIES

OPTICAL MICROMETER



FDRF656 Series

Contents

1. Safety precautions.....	4
2. CE compliance.....	4
3. Laser safety.....	4
4. General information.....	4
5. Basic technical data.....	5
6. Example of item designation when ordering.....	5
7. Structure and operating principle.....	7
8. Options for use of the device.....	7
8.1. One-coordinate systems.....	7
8.2. Multi-axis systems.....	7
9. Dimensions and mounting.....	8
10. Connection.....	9
10.1. Micrometers without logical outputs.....	9
10.2. Micrometers with cable gland and cables.....	9
10.3. Ethernet cable.....	10
11. Configuration parameters.....	11
11.1. Parameter of Synchronization.....	11
11.2. Sampling period.....	11
11.3. Method of results averaging.....	11
11.4. Number of averaged values/time of averaging.....	12
11.5. Measurement modes.....	12
11.6. Borders and polarity.....	12
11.7. Numbers of borders under control.....	13
12. Description of RS232 and RS485 interfaces.....	13
12.1. RS232 port.....	13
12.2. RS485 port.....	13
12.3. Modes of data transfer.....	13
12.4. Configuration parameters.....	13
12.4.1. Rate of data transfer through serial port.....	13
12.4.2. Net address.....	13
12.4.3. Factory parameters table.....	14
12.5. Interfacing protocol.....	14
12.5.1. Serial data transmission format.....	14
12.5.2. Communication sessions types.....	14
12.5.3. Request.....	14
12.5.4. Message.....	14
12.5.5. Answer.....	15
12.5.6. Data stream.....	15
12.5.7. Request codes and list of parameters.....	15
13. Analog and logical outputs.....	15
13.1. Modes of data transfer.....	15
13.2. Current output 4...20 mA.....	15
13.3. Voltage output 0...10 V.....	16
13.4. Configuration parameters.....	16
13.4.1. Range of the analog output.....	16
13.5. Logical outputs operation modes.....	16
14. Request codes and list of parameters.....	17
14.1. Request codes.....	17
14.2. List of parameters.....	17
14.3. Factory parameters by default.....	20
14.4. Examples of setting the measurement mode.....	20
14.5. Example of measurement request.....	21

15. Ethernet packet.....	22
16. Parameterization program.....	22
16.1. Function.....	22
16.2. Obtaining connection to micrometer.....	22
16.3. Setting and saving parameters of the micrometer.....	23
16.4. Setting the measurement modes.....	24
17. Working with micrometer.....	26
18. Examples of stream setting.....	27
18.1. Data transfer by request.....	27
18.2. Synchronous data transfer.....	27
18.3. Setting the logical outputs.....	28
19. RF65X-SDK.....	29
20. Warranty policy.....	29
21. Distributors.....	29

1. Safety precautions

- Use supply voltage and interfaces indicated in the sensor specifications.
- In connection/disconnection of cables, the micrometer power must be switched off.
- Do not use micrometers in locations close to powerful light sources.
- To obtain stable results, wait about 20 minutes after micrometer activation to achieve uniform micrometer warm-up.

2. CE compliance

The micrometers have been developed for use in industry and meet the requirements of the following Directives:

- EU directive 2014/30/EU. Electromagnetic compatibility (EMC).
- EU directive 2011/65/EU, "RoHS" category 9.

3. Laser safety

The micrometers make use of a LED. The micrometers belong to the 1 laser safety class. The following warning label is placed on the housing:



The following safety measures should be taken while operating the micrometer:

- Avoid staring into the emitter during a prolonged time period.
- Do not disassemble the micrometer.

4. General information

The micrometers are intended for non-contact measuring and checking of diameters, gaps, displacement/position of the edges of technical objects. The series includes 6 models with the measurement range from 5 to 100 mm.

5. Basic technical data

FDRF656-		5	10	25	50	75	100
Measurement range, mm		±1x5	±3x10	±5x25	±7x50	±9x75	±10x100
Minimum size of the object ¹ , mm		0.05(0.1)	0.1(0.2)	0.25(0.5)	0.5(1)	0.75(1.5)	1(2)
Accuracy ² , µm		±0.3	±0.5	±1	±2	±3	±5
Repeatability ³ , µm		0,1	0,2	0,5	1	1,5	2
Maximum scanning frequency, Hz		2000	10000	10000	10000	10000	10000
Maximum update frequency, Hz		500	2000	2000	2000	2000	2000
Light source		LED					
Lase safety class		1 (IEC60825-1)					
Output interface	digital	RS232 (max 921.6 kbit/s) or RS485 (max 921.6 kbit/s) or Ethernet & (RS32 or RS485)					
	analog	4...20 mA (load ≤ 500 Ohm) or 0...10 V					
Synchronization input		2.4 – 5 V (CMOS, TTL)					
Logic output		three outputs, NPN: 100 mA max; 40 V max					
Power supply, V		24 (9...36)					
Power consumption, W		from 1.5 to 2					
Environment resistance	Enclosure rating	IP67					
	Vibration	20 g / 10...1000 Hz, 6 hours for each of XYZ axes					
	Shock	30 g / 6 ms					
	Operation temperature, °C	-10...+60					
	Relative humidity	5-95%					
Housing material		aluminum					
Weight (without cable), gram		700	700	700	1600	3200	4500

1. With using the "Dia Correction" parameter (without using the "Dia Correction" parameter).
2. Specified for controlling the border position of the "knife" type, when the distance between the transmitter and the receiver is equal to the double measurement range.
3. When the "Averaging" parameter is equal to 127.

6. Example of item designation when ordering

FDRF656-X-SERIAL-ANALOG- LOUT- IN-CC-M-AK

Symbol	Description
X	Measurement range, mm
L	Distance between transmitter and receiver, mm
SERIAL	The type of serial interface: RS232 - 232 or RS485 - 485 or (Ethernet and RS232) – 232-ET, or (Ethernet and RS485) – 485-ET
ANALOG*	Attribute showing the presence of 4...20 mA (I) or 0...10 V (U)
LOUT*	Attribute showing the presence of 3 logical outputs
IN	Trigger input (input of synchronization) presence
CC	Cable gland - CG, or cable connector - CC
M	Cable length, m
AK	Micrometer with protect air knife for windows

* It is possible to order modifications only with the logical output or with the analog output.

Example: FDRF656-25/50-232-I-IN-CG-3 – measurement range – 25 mm, distance between transmitter and receiver – 50 mm, RS232 serial port, 4...20 mA analog output, trigger input is available, cable connector, 3 m cable length.

Modifications:

Model	Valid values for the parameters
FDRF656-5/L-SERIAL-ANALOG(LOUT)-IN-CC-M-AK	L – 36 mm SERIAL – 232, 485, 232-ET, 485-ET ANALOG – no, I, U LOUT – no, LOUT IN - IN CC – CG, CC M – 0,1 m...10 m AK – no, AK
FDRF656-10/L-SERIAL-ANALOG(LOUT)-IN-CC-M-AK	L – 56 mm...100 mm SERIAL – 232, 485, 232-ET, 485-ET ANALOG – no, I, U LOUT – no, LOUT IN - IN CC – CG, CC M – 0,1 m...10 m AK – no, AK
FDRF656-25/L-SERIAL-ANALOG(LOUT)-IN-CC-M-AK	L – 50 mm...100 mm (large base on request) SERIAL – 232, 485, 232-ET, 485-ET ANALOG – no, I, U LOUT – no, LOUT IN - IN CC – CG, CC M – 0,1 m...10 m AK – no, AK
FDRF656-50/L-SERIAL-ANALOG(LOUT)-IN-CC-M-AK	L – 50 mm...200 mm (large base on request) SERIAL – 232, 485, 232-ET, 485-ET ANALOG – no, I, U LOUT – no, LOUT IN - IN CC – CG, CC M – 0,1 m...10 m AK – no, AK
FDRF656-75/L-SERIAL-ANALOG(LOUT)-IN-CC-M-AK	L – 50 mm...225 mm (large base on request) SERIAL – 232, 485, 232-ET, 485-ET ANALOG – no, I, U LOUT – no, LOUT IN - IN CC – CG, CC M – 0,1 m...10 m AK – no, AK
FDRF656-100/L-SERIAL-ANALOG(LOUT)-IN-CC-M-AK	L – 50 mm...300 mm (large base on request) SERIAL – 232, 485, 232-ET, 485-ET ANALOG – no, I, U LOUT – no, LOUT IN - IN CC – CG, CC M – 0,1 m...10 m AK – no, AK

7. Structure and operating principle

The micrometer operation is based on the so-called 'shadow' principle, Figure 1. The micrometer consists of two blocks – transmitter and receiver. Radiation of a semiconductor laser or LED 1 is collimated by a lens 2. With an object placed in the collimated beam region, shadow image formed is scanned with a CCD photo-detector array 3. A processor 4 calculates the position (size) of the object from the position of shadow border (borders).

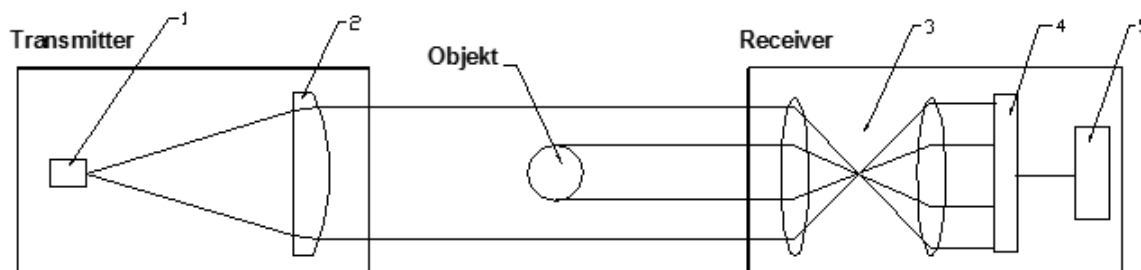

8. Options for use of the device

8.1. One-coordinate systems

Ways of using the micrometer for gauging of technological objects are shown in Figure 2.

Fig. 2.1 – measuring of the edge position; Fig. 2.2. – measuring of size or position; Fig. 2.3. – measuring of the gap value or position; Fig. 2.4. – measuring of internal or external dimension; Fig. 2.5. – measuring of the size or position of large-size objects.

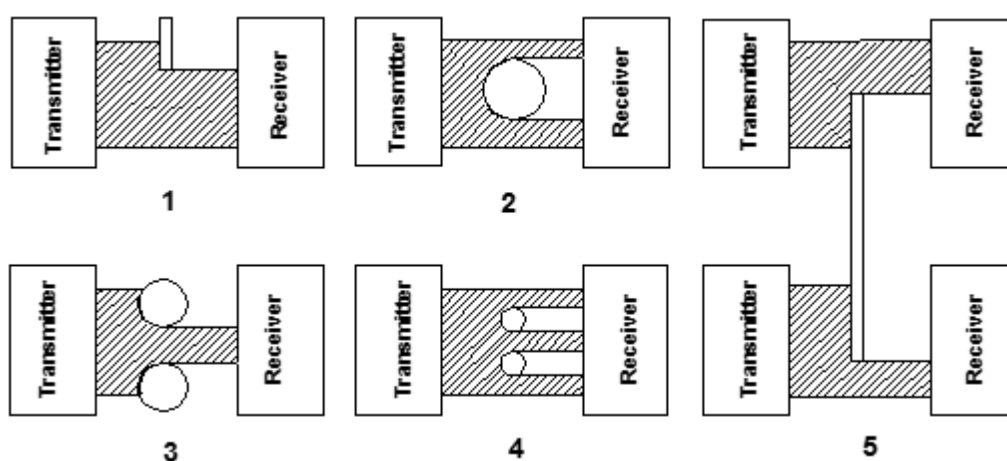

Figure 2

8.2. Multi-axis systems

Delivery of multi-axis measurement system (measured in several sections) is possible. Examples of the 2D and 3D coordinate systems are shown in Figures 3.1 and 3.2, respectively. An example of item designation when ordering 2D coordinate systems -FDRF651XY-X/L..., for systems with more axes - FDRF651.N-X/L..., where N is a number of coordinates in the system.

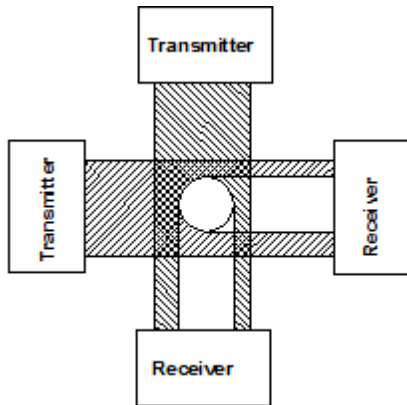

Figure 3.1.

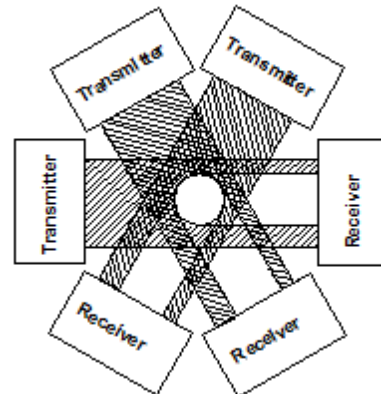

Figure 3.2.

9. Dimensions and mounting

Overall and mounting dimensions of micrometers are shown in Figure 4.

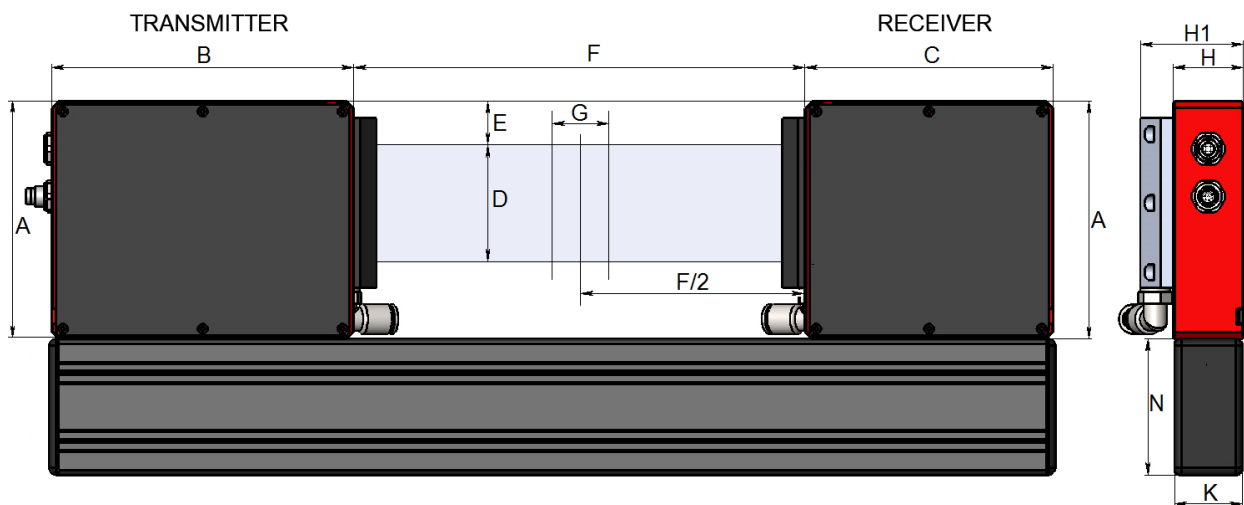

Figure 4

	A, mm	B, mm	C, mm	D, mm	E, mm	F, mm	G, mm	H, mm	H1, mm	K, mm	N, mm
FDRF656-5	66	142	50	5	14	36	1	28	42.5	30	30
FDRF656-10	50	126	70	10	12	56	3	28	42.5	30	30
FDRF656-25	72	106	74	25	7	63	5	28	42.5	30	30
FDRF656-50	105	134	110	50	19	200	7	31	45.5	30	60
FDRF656-75	135	148	125	75	17	200	9	31	45.5	40	80
FDRF656-100	175	170	160	100	20	300	10	31	45.5	40	80

10. Connection

Micrometers are equipped with cable glands (CG option), or connectors (CC option). Micrometers with an Ethernet interface contains two cable glands or two connectors.

10.1. Micrometers without logical outputs

Micrometer is equipped with Binder 702-8 connector. Pin numbers and location of the installation is shown in Figure 5.



Figure 5

Designation of contacts is given in the following table:

Model of Micrometer	Pin number	Assignment
232 - U/I - IN-AL - CC	1	IN
	2	Gnd (power supply)
	3	TXD
	4	RXD
	5	Gnd (common for signals)
	6	AL (LOUT_max)
	7	U/I (LOUT_min)
	8	U+ (power supply)
485 - U/I - IN-AL - CC	1	IN
	2	Gnd (power supply)
	3	DATA+
	4	DATA-
	5	Gnd (common for signals)
	6	AL (LOUT_max)
	7	U/I (LOUT_min)
	8	U+ (power supply)

10.2. Micrometers with cable gland and cables

The place of the cable entry is shown in Figure 6.

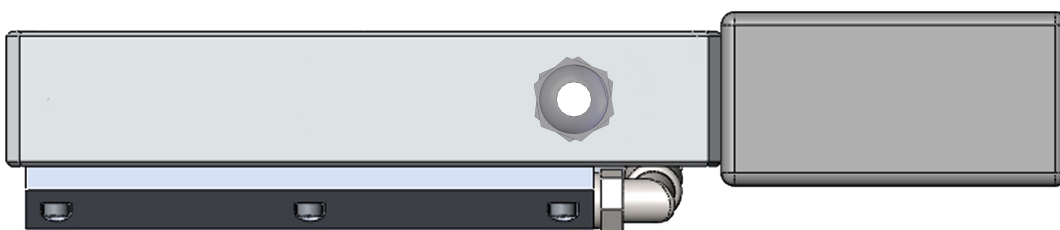

Figure 6

Designation of cable wires for micrometers with cable gland and cable of micrometers with cable connector is given in the following table:

Model of Micrometer	Pin number	Assignment	Wire color	
232-U/I-IN - CG	free wire	-	IN	White
	free wire	-	Gnd (power supply)	Brown
	DB9	2	TXD	Green
	DB9	3	RXD	Yellow
	DB9	5	Gnd (common for signals)	Gray
	free wire	-	U/I	Blue
	free wire	-	U+ (power supply)	Red
485-U/I-IN - CG	free wire	-	IN	White
	free wire	-	Gnd (power supply)	Brown
	DB9	8	DATA+	Green
	DB9	7	DATA-	Yellow
	DB9	5	Gnd (common for signals)	Gray
	free wire	-	U/I	Blue
	free wire	-	Питание U+	Red
232-LOUT-CG	free wire	-	Gnd (power supply)	Brown
	DB9	2	TXD	Green
	DB9	3	RXD	Yellow
	DB9	5	Gnd (common for signals)	Gray
	free wire	-	U+ (power supply)	Red
	free wire	-	IN	White
	free wire	-	UpLimit	Pink
	free wire	-	LowLimit	Blue
485 - OUT - CG	free wire	-	Gnd (power supply)	Brown
	DB9	8	DATA+	Green
	DB9	7	DATA-	Yellow
	DB9	5	Gnd (common for signals) U	Gray
	free wire	-	+ (power supply)	Red
	free wire	-	IN	White
	free wire	-	UpLimit	Pink
	free wire	-	LowLimit	Blue

10.3. Ethernet cable

The place of the cable entry is shown in Figure 7.

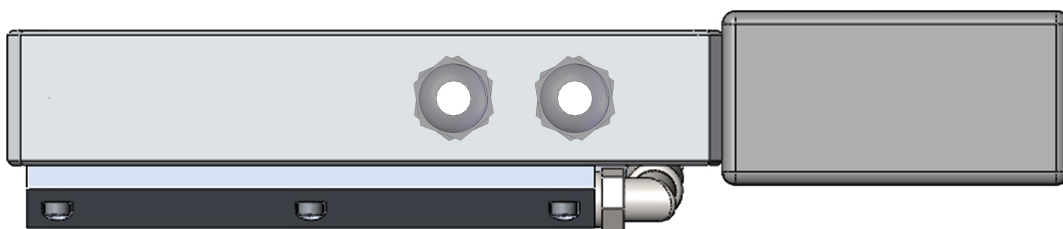

Figure 7

Designation of cable wires is given in the following table:

Model of Micrometer	Pin number	Assignment
ET	TX+	Orange White-
	TX-	Orange Green
	RX+	White-Green
	RX-	

11. Configuration parameters

The nature of operation of the micrometer depends on its configuration parameters (operation modes), which can be changed only by transmission of commands through serial port RS232 or RS485. The basic parameters are as follows:

11.1. Parameter of Synchronization

This parameter specifies one of the three result sampling options in the case where the micrometer works in the data stream mode:

- Asynchronous Transmission
- Synchronous transmission, Time Sampling
- Synchronous transmission, Trigger Sampling

With Asynchronous Transmission selected, the micrometer automatically transmits

the measurement result via serial interface as it is ready.

With Time Sampling selected, the micrometer automatically transmits the measurement result via serial interface in accordance with selected time interval (sampling period). With Trigger Sampling selected, the micrometer transmits the measurement result when external synchronization input (IN input of the micrometer) is switched and taking the division factor set into account.

Note. The mode of operation of each of the interfaces can be set independently.

11.2. Sampling period

If the Time Sampling mode is selected, the 'sampling period' parameter determines the time interval in which the micrometer will automatically transmit the measurement result. The time interval value is set in increments of 0.1 ms. **For example**, for the parameter value equal to 100, data are transmitted through bit-serial interface with a period of $0.1 \cdot 100 = 10$ ms.

If the Trigger Sampling mode is selected, the 'sampling period' parameter determines the division factor for the external synchronization input. **For example**, for the parameter value equal to 100, data are transmitted through bit-serial interface when each 100th synchronizing pulse arrives at IN input of the sensor.

Note 1. It should be noted that the 'sampling mode' and 'sampling period' parameters control only the transmission of data. The micrometer operation algorithm is so built that measurements are taken at a maximum possible rate determined by the integration time period, the measurement results is sent to buffer and stored therein until a new result arrives. The above-mentioned parameters determine the method of the readout of the result from the buffer.

Note 2. If the bit-serial interface is used to receive the result, the time required for data transmission at selected data transmission rate should be taken into account in the case where small sampling period intervals are used. If the transmission time exceeds the sampling period, it is this time that will determine the data transmission rate.

11.3. Method of results averaging

The averaging can operate in three modes:

- Off, no averaging
- Averaging over a number of results
- Averaging over the measurement time (5 ms)

When averaging over a number of results is selected, sliding average is calculated.

The use of averaging makes it possible to reduce the output noise and increase the micrometer resolution.

11.4. Number of averaged values /time of averaging

This parameter specifies the number of source results to be averaged for deriving the output value. Averaging over a number of results does not affect the data update in the micrometer output buffer.

Note. The maximum value is 127.

11.5. Measurement modes

The micrometer can operate in the following modes:

- Measurement of the position of one border (knife).
- The distance between borders A and B (measuring the size of the object or hole). Result = B - A.
- The position of the object (its center). Result = (B + A) / 2.
- Detection of the first two borders in the measurement range. The position of these borders is transferred. This mode is used for turning products
- Measurement of glass tubes. Detection of the first border and the last border, and calculation of the distance between them.
- Detection of all borders in the measurement range. The number of detected borders and their position are transferred. The maximum number of borders: 64 (for UART interface) and 7 (for Ethernet interface).
- Measurement of thin films. Detection of the film edge with the polarity corresponding to the "Polarity of the border A under control" parameter (see p. [14.2](#)).

In addition, since it is possible to set the polarity and the border numbers, you can measure objects with a more complex shape.

11.6. Borders and polarity

The border means "light-shadow" transition or "shadow-light" transition which forms a shadow image of the object (see Figure 8). Measurement is only conducted in the case where the number of borders detected by micrometer corresponds to a given parameter. The polarity is the "light-shadow" transition or "shadow-light" transition. Borders can be set with the same polarity and with the different polarity.

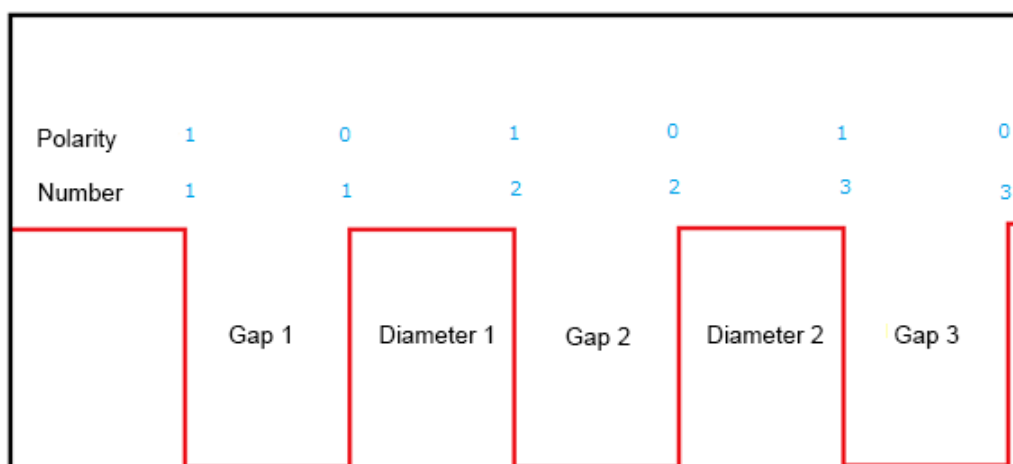

Figure 8

11.7. Numbers of borders under control

The measurement domain can include up to 64 borders, however, measurement can be made in relation to any two borders (hereinafter – borders **A** and **B**), whose numbers are specified by this parameter. Border numbers are counted in the direction of scanning. Direction of scanning is indicated on the body of receiver.

12. Description of RS232 and RS485 interfaces

12.1. RS232 port

The RS232 port ensures a “point-to-point” connection and allows the sensor to be connected directly to RS232 port of a computer or controller.

12.2. RS485 port

In accordance with the protocol accepted and hardware capability, the RS485 port makes it possible to connect up to 127 sensors to one data collection unit by a common bus circuit.

12.3. Modes of data transfer

Through these serial interfaces measurement data can be obtained by three methods:

- by single requests (inquiries);
- by automatic asynchronous data stream (results are transmitted as they become available);
- by automatic synchronous data stream (time sampling or trigger sampling).

12.4. Configuration parameters

12.4.1. Rate of data transfer through serial port

This parameter defines the rate of data transmission via the bit-serial interface in increments of 2400 bit/s. For example, the parameter value equal to 4 gives the transmission rate of $2400 \times 4 = 9600$ bit/s.

Note. The maximum transmission rate for RS232/RS485 interfaces is 921,6 kbit/s.

12.4.2. Net address

This parameter defines the network address of the sensor equipped with RS485 interface.

Note. Network data communications protocol assumes the presence of ‘master’ in the net, which can be a computer or other information-gathering device, and from 1 to 127 ‘slaves’ (FDRF65x Series sensors) which support the protocol.

Each ‘slave’ is assigned a unique network identification code – a device address. The address is used to form requests or inquiries all over the net. Each slave receive inquiries containing its unique address as well as ‘0’ address which is broadcast-oriented and can be used for formation of generic commands, for example, for simultaneous latching of values of all sensors and for working with only one sensor (with both RS232 port and RS485 port).

12.4.3. Factory parameters table

Parameter	Value
Baud rate	115200
Net address	1
Mode of data transfer	request

12.5. Interfacing protocol

12.5.1. Serial data transmission format

Data message has the following format:

	8 data bits	1 odd bit	1 stop-bit
--	-------------	-----------	------------

12.5.2. Communication sessions types

The communications protocol is formed by communication sessions, which are only initiated by the 'master' (PC, controller). There are two kinds of sessions with such structures:

- 1) "request", ["message"] — ["answer"], *square brackets include optional elements*
- 2) "request" — "data stream" — ["request"].

12.5.3. Request

"Request" (INC) — is a *two-byte* message, which fully controls communication session. The 'request' message is the only one of all messages in a session where *the most significant bit is set at 0*, therefore, it serves to synchronize the beginning of the session. In addition, it contains the device address (ADR), code of request (COD) and, optional, the message [MSG].

"Request" format:

Byte 0	Byte 1	[Bites 2...N]
INC0(7:0)	INC1(7:0)	MSG
0 ADR(6:0)	1 0 0 0 COD(3:0)	

12.5.4. Message

"Message" is data burst that can be transmitted by 'master' in the course of the session. All messages with a "message" burst contain 1 in the most significant digit. Data in a message are transferred in tetrads. When byte is transmitted, lower tetrad goes first, and then follows higher tetrad. When multi-byte values are transferred, the transmission begins with lower byte.

The following is the format of two 'message' data bursts for transmission of byte:

DAT(7:0)											
Byte 0						Byte 1					
1	0	0	0	DAT(3:0)		1	0	0	0	DAT(7:4)	

12.5.5. Answer

"Answer" is data burst that can be transmitted by 'slave' in the course of the session. All messages with a message burst contain 1 in the most significant digit. *Data in a message are transferred in tetrads.* When byte is transmitted, lower tetrad goes first, and then follows higher tetrad. When multi-byte values are transferred, the transmission begins with lower byte.

When 'answer' is transmitted, the message contains:

- SB-bit, characterizes the updating of the result. If SB is equal to "1" this means that the sensor has updated the measurement result in the buffer, if SB is equal to "0" - then non-updated result has been transmitted (see. Note 1, p.10.3.). SB=0 when parameters transmit;
- two additional bits of cyclic binary batch counter (CNT). Bit values in the batch counter are identical for all sendings of one batch. The value of batch counter is incremented by the sending of each burst and is used for formation (assembly) of batches or bursts as well as for control of batch losses in receiving data streams.

The following is the format of two 'answer' data bursts for transmission of byte:

DAT(7:0)							
Byte 0				Byte 1			
1	SB	CNT(1:0)	DAT(3:0)	1	SB	CNT(1:0)	DAT(7:4)

12.5.6. Data stream

'Data stream' is an infinite sequence of data bursts or batches transmitted from 'slave' to 'master', which can be interrupted by a new request. In transmission of 'data stream' one of the 'slaves' fully holds data transfer channel, therefore, when 'master' produces any new request sent to any address, data streaming process is stopped. Also, there is a special request to stop data streaming.

12.5.7. Request codes and list of parameters

Request codes and a list of parameters are presented in Chapter [14](#).

13. Analog and logical outputs

13.1. Modes of data transfer

The micrometer can be operated in the following modes:

- No transmission.
- Automatic asynchronous data stream (results are transmitted as they become available).
- Automatic synchronous data stream (time sampling or trigger sampling).

13.2. Current output 4...20 mA

The connection scheme is shown in Figure 9. The value of load resistor should not be higher than 500 Ohm. To reduce noise, it is recommended to install RC filter before the measuring instrument. The filter capacitor value is indicated for maximum sampling frequency of the micrometer (2 kHz) and this value increases in proportion to the frequency reduction.

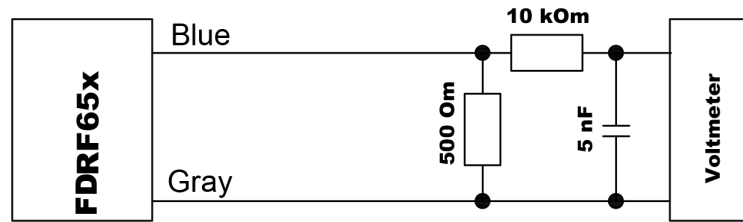

Figure 9

13.3. Voltage output 0...10 V

The connection scheme is shown in Figure 10. To reduce noise, it is recommended to install RC filter before the measuring instrument. The filter capacitor value is indicated for maximum sampling frequency of the micrometer (2 kHz) and this value increases in proportion to the frequency reduction.

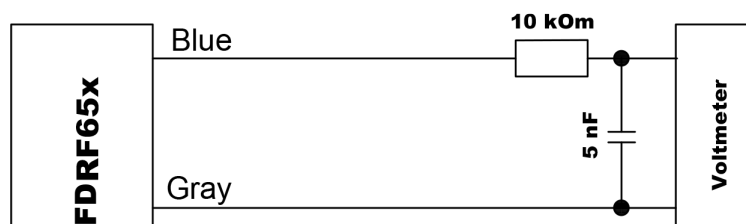

Figure 10

13.4. Configuration parameters

13.4.1. Range of the analog output

While working with the analog output, resolution can be increased by using the 'Window in the operating range' function which makes it possible to select a window of required size and position in the operating range of the sensor within which the whole range of analog output signal will be scaled.

Note. If the beginning of the range of the analog signal is set at a higher value than the end value of the range, this will change the direction of rise of the analog signal.

13.5. Logical outputs operation modes

Logical outputs of the micrometer are used to signal that the size under control is within or outside the tolerances selected. Logics of operation of the outputs can be changed, i.e. activate either low or high logical level. See par. [14.2](#), parameter 81h. Wiring diagram of logical outputs is shown in Figure 11:

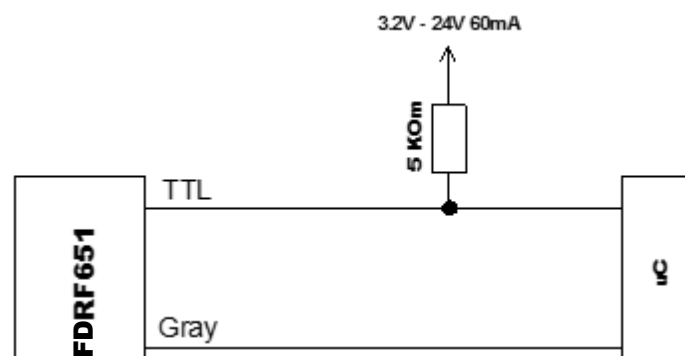

Figure 11

14. Request codes and list of parameters

14.1. Request codes

Request code	Description	Message (size in bytes)	Answer (size in bytes)
01h	Device identification	—	- device type (1) - firmware version (1) - serial number (2) - base distance (2) - range (2)
02h	Reading of parameter	- code of parameter (1)	- value of parameter (1)
03h	Writing of parameter	- code of parameter (1) - value of parameter (1)	—
04h	Storing current parameters to FLASH-memory	- constant AAh (1)	- constant AAh (1)
04h	Recovery of parameter default values in FLASH-memory	- constant 69h (1)	- constant 69h (1)
05h	Latching of current result	—	—
06h	Inquiring of result	—	- result (2)
07h	Inquiring of a stream of results	—	- stream of results (2)
08h	Stop data streaming	—	—

14.2. List of parameters

Code	Description	Values
00h	Switching ON/OFF the sensor	1 - laser ON, measuring (by default); 0 - laser OFF, the sensor is in the energy-saving mode.
01h	Switching ON/OFF the analog output	1 - ON; 0 - OFF.
02h	Control of averaging, sampling, AL-output modes	x,x,M,C,M1,M0,R,S – control byte (x bits - not used, M bit - the averaging mode, C bit - CAN interface, M0 and M1 bits - logical output, R bit - analog output, S bit - sampling mode). M bit: 0 - averaging the measured values by quantity (by 1 - default); 1 - averaging the measured values by time (5 ms); C bit: 0 - request (by default); 1 - synchronization by time, or by external input. M1:M0 bits: 00 - out-of-range indication mode (by default); 01 - mutual synchronization mode; 10 - mode of results reset. 11 - mode of switching ON/OFF a laser R bit: 0 - window mode (by default); 1 - full mode. S bit: 0 - time sampling mode (by default); 1 - trigger sampling mode.
03h	Network address	1...127 (by default, 1).

Code	Description	Values
04h	Rate of data transfer through a serial port	1...192 (by default, 4). The rate of data transfer in increments of 2400 bit/s. For example, the parameter value equal to 4 gives the transmission rate of $2400 \cdot 4 = 9600$ bit/s.
05h	<i>Reserved</i>	
06h	Number of averaged values	1...128 (by default, 1).
07h	<i>Reserved</i>	
08h	Low byte of sampling period	1) 1...65535 (by default, 500).
09h	High byte of sampling period	Time interval in increments of 0.01 ms, that a sensor uses to transmit results automatically on the data stream request (sampling priority = 0); 2) 1...65535 (by default, 500). Division factor for synchronization input (sampling priority = 1).
0Ah	Low byte of the maximum accumulation time	2...65535 (by default, 3200). The maximum accumulation time in increments of 1 μ s.
0Bh	High byte of the maximum accumulation time	
0Ch	Low byte of the beginning of analog output range	In percents (by default, 0). The point within the range of the micrometer, at which the analog output takes the minimum value.
0Dh	High byte of the beginning of analog output range	
0Eh	Low byte of the end of analog output range	In percents (by default, 100). The point within the range of the micrometer, at which the analog output takes the maximum value.
0Fh	High byte of the end of analog output range	
10h	Delay time	0...255. The delay time in increments of 5 ms.
11h	Measurement type	1 (by default) – Measuring the position of one border (knife); 2 – Distance between borders A and B (measuring the size of the object). Result = B – A. (Numbers of borders A and B are set by parameters 0x12h and 0x14 h). 3 – Position of the object – (B+A)/2. 4 – Detection of the first two borders in the measurement range. 5 – Distance between borders of a glass object. 6 – Detection of all borders in the measurement range. The maximum number of borders: 64 (for UART interface) and 7 (for UDP interface). 7 – Position of the film edge.
12h	Number of the border under control (Border A Number)	0-127 (by default, 0x01h). A – a serial number of border A.
13h	Polarity of the border under control (Border A Polarity)	0-1 (by default, 0x00h).
14h	Number of the border under control (Border B Number)	0-127 (by default, 0x01h). B – a serial number of border B.
15h	Polarity of the border under control (Border B Polarity)	0-1 (by default, 0x01h).
16h	<i>Reserved</i>	
17h	Low byte of a zero point	0...4000h (by default, 0).
18h	High byte of a zero point	
19...1Ch	<i>Reserved</i>	
20h	Rate of data transfer through the CAN interface	10...200 (by default, 25). Rate of data transfer in increments of 5000 baud. For example, value '50' sets the rate of $50 \cdot 5000 = 250000$ baud.
22h	Low byte of the standard identifier	0...7FFh (by default, 7FFh). The standard identifier of the CAN interface.

Code	Description	Values
23h	High byte of the standard identifier	
24h	0th byte of the extended identifier	0...1FFFFFFFh (by default, 1FFFFFFFh). The extended identifier of the CAN interface.
25h	1st byte of the extended identifier	
26h	2nd byte of the extended identifier	
27h	3rd byte of the extended identifier	
28h	Identifier of the CAN interface	1 - extended identifier; 0 - standard identifier.
29h	CAN interface ON/OFF	1 - CAN interface enabled; 0 - CAN interface disabled.
0x39h	Analog output operation mode	0 (by default) - window mode; 1 - deviation mode.
6Ch	0th byte of the destination IP address	by default, FFFFFFFFh = 255.255.255.255
6Dh	1st byte of the destination IP address	
6Eh	2nd byte of the destination IP address	
6Fh	3rd byte of the destination IP address	
70h	0th byte of the gateway IP address	by default, COA80001h = 192.168.0.1
71h	1st byte of the gateway IP address	
72h	2nd byte of the gateway IP address	
73h	3rd byte of the gateway IP address	
74h	0th byte of the subnet mask	by default, FFFFFFF0h = 255.255.255.0
75h	1st byte of the subnet mask	
76h	2nd byte of the subnet mask	
77h	3rd byte of the subnet mask	
78h	0th byte of the source IP address	by default, COA80003h = 192.168.0.3
79h	1st byte of the source IP address	
7Ah	2nd byte of the source IP address	
7Bh	3rd byte of the source IP address	
81h	Mask of logical outputs polarity	x,x,x,x,x,c,b,a – byte that specifies polarity of logical outputs; x bits – not used; a bit: 0 — logical output LowLimit – normally open (by default); 1 — logical output LowLimit – normally closed; b bit: 0 — logical output NormLimit – normally open (by default); 1 — logical output NormLimit – normally closed; c bit: 0 — logical output UpLimit – normally open (by default); 1 — logical output UpLimit – normally closed;

Code	Description	Values
82h	1st byte of the lower border of the logical output	by default, 10000
83h	2nd byte of the lower border of the logical output	
84h	1st byte of the upper border of the logical output	by default, 20000
85h	2nd byte of the upper border of the logical output	
86h	1st byte of the diameters correction	by default, 0
87h	2nd byte of the diameters correction	
88h	ETHERNET interface ON/OFF	0 - ETHERNET interface disabled; 1 - ETHERNET interface enabled in the UDP mode.
A0h	1st byte of the division factor for results calculation	by default, 50000
A1h	2nd byte of the division factor for results calculation	

NOTES:

- All values are given in binary form.
- The range is given in millimeters.
- On special request (05h), the current result can be latched in the output buffer where it will be stored unchanged up to the moment of arrival of request for data transfer. This request can be sent simultaneously to all micrometers in the net in the broadcast mode in order to synchronize data pickup from all micrometers.
- When working with the parameters, it should be borne in mind that when power is OFF the parameter values are stored in nonvolatile FLASH-memory of the sensor. When power is ON, the parameter values are read out to RAM of the sensor. In order to retain these changes for the next power-up state, a special command for saving current parameter values in the FLASH-memory (04h) must be run.
- Parameters with the size of more than one byte should be saved starting from the high-order byte and finishing with the low-order byte.

WARNING! It is forbidden to carry out the configuration of sensors included in the RS485 network.

14.3. Factory parameters by default

The parameters are stored in nonvolatile memory of the micrometer. Correct changing of the parameters is carried out by using the parametrization program supplied with the micrometer, or by the user's program.

14.4. Examples of setting the measurement mode

The following parameters are used for setting the measurement mode:

- Out Data Format (11h);
- Border A Number (12h);
- Border A Polarity (13h);
- Border B Number (14h);
- Border B Polarity (15h).
- Measuring the position of one border (knife)

Out Data Format – 1
 Border A Number – 1
 Border A Polarity – 0
 Border B Number – 1
 Border B Polarity – 1

- The distance between borders A and B

Finding the diameter of the object:

Out Data Format – 2
 Border A Number – 1
 Border A Polarity – 0
 Border B Number – 1
 Border B Polarity – 1

Finding the gap dimensions: Out

Data Format – 2
 Border A Number – 1
 Border A Polarity – 1
 Border B Number – 1
 Border B Polarity – 0

- The position of the object (a center of the object/gap)

Out Data Format – 3
 Border A Number – 1
 Border A Polarity – 0
 Border B Number – 1
 Border B Polarity – 1

How to configure the measurement mode using the software, see p. [16.4](#). The description of the "Border" and "Polarity" terms is given in p. [11.6](#).

14.5. Example of measurement request

An example of forming the packets with requests and answers:

Network address – 1.

Measurement range = 25 mm.

Scaling = 50000.

Request [2 bytes]: 0x01, 0x86. (0x01 – 1st byte – network address)

Answer [4 bytes]: InData[0], InData[1], InData[2], InData[3]

An example of forming a packet with measurement (4 bits from each received byte):

$Y = \text{InData}[0] \& 0x0F | (\text{InData}[1] \& 0x0F) \ll 4 | (\text{InData}[2] \& 0x0F) \ll 8 | (\text{InData}[3] \& 0x0F)$

<<12;

Measurement results will be in mm.

Result = $Y * \text{Measurement range} / \text{Scaling}$

Example: $Y = 0x1234$ (4660)

Result = $4660 * 25 / 50000 = 2,33$ mm

15. Ethernet packet

Address	Name	Length	Type	Example
0	Name	2	char	0x5246
2	Sensor type	1	word	656 (651)
4	Packet length	1	word	36
6	Data offset	1	byte	20
7	Number of measurements in the packet	1	byte	1
8	Packets counter	1	word	1
10	Version	1	byte	1
11	Serial number	1	word	2515
13	Measurement range	1	word	100
15	Scaling factor	1	word	50000
17	Data output format	1	byte	11h parameter
18	Sign of the 1st border	1	byte	0
19	Number of borders	1	byte	1
20	Data	1	word	4660
22	Status	1	byte	0
23-36	Data, status or NULL			

16. Parameterization program

16.1. Function

The FDRF65X-SP software is intended

- 1) Testing and demonstration of work of FDRF651 series micrometers;
- 2) Setting of the micrometer parameters;
- 3) Reception and gathering of the micrometer data signals.

16.2. Obtaining connection to micrometer

Once the program is started, the main window emerges:

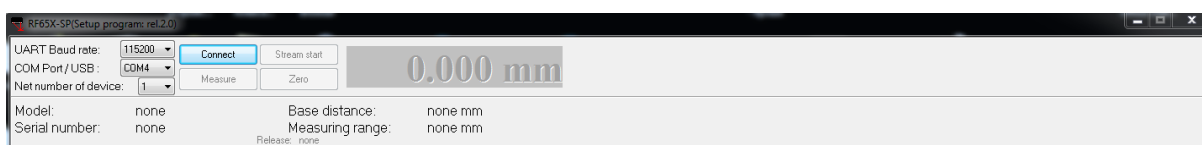

To obtain connection, it is necessary to follow these steps:

- select COM-port whereto the sensor is connected (logical port if the sensor is connected via USB-adapter)
- select transmission rate (Baud rate) at which the sensor will work (115200, by default)
- select the sensor network address (1, by default)
- press **Connect** button

If the selected parameters correspond to the parameters of the micrometer interface, the program will identify the micrometer, read and display its configuration parameters:

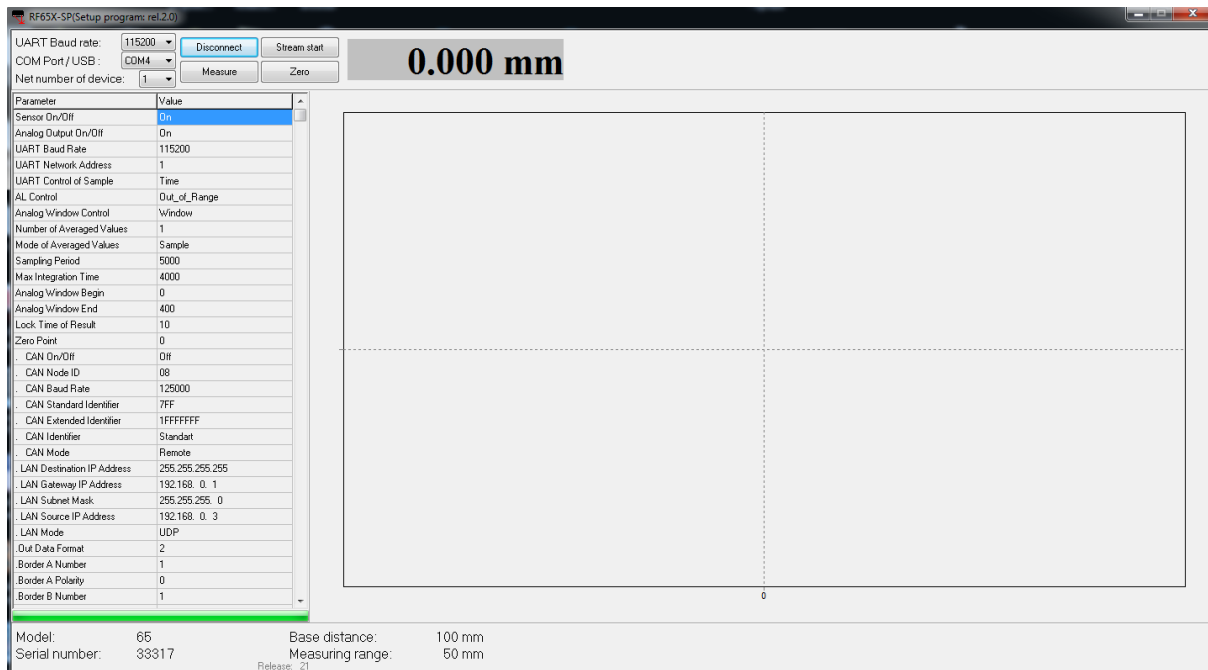

16.3. Setting and saving parameters of the micrometer

The part of FDRF65x application, which has become an active, allows to edit and to put in RAM and FLASH memory of micrometer the appropriate parameters. Configuring the micrometer is done by selecting the appropriate item from the proposed drop-down menu, or by entering the absolute value of the desired parameter (all parameters are entered in decimal form, the user must follow the correct input of a specific parameter). After selecting the desired value from the drop-down menu or after entering the absolute value, it is necessary to write them to RAM. To do it, you need to press the right mouse key on the table of parameters. The pop-up window will appear. In this pop-up window, select **Load** (to save the selected item) or **Load All** (to save all settings).

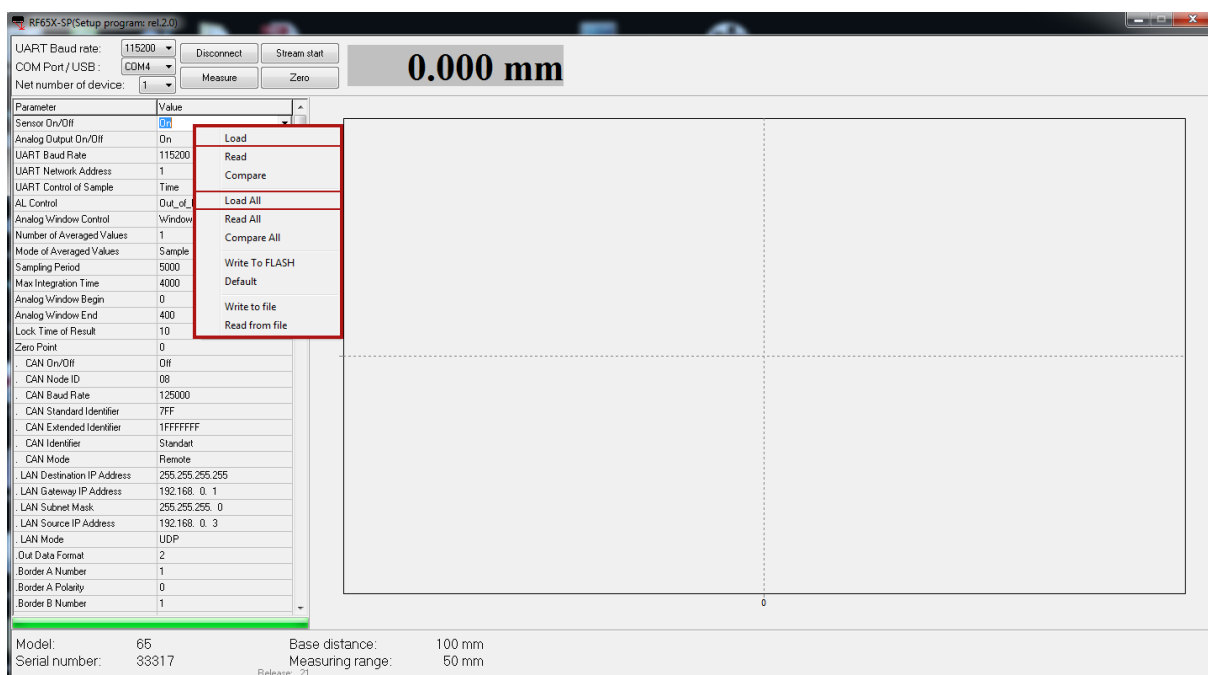

In the pop-up window there are two items: **Write To FLASH** and **Default**. The **Write To FLASH** item allows to save the current parameters from the RAM of micrometer to the non-volatile memory. The **Default** item allows to restore factory settings of the micrometer.

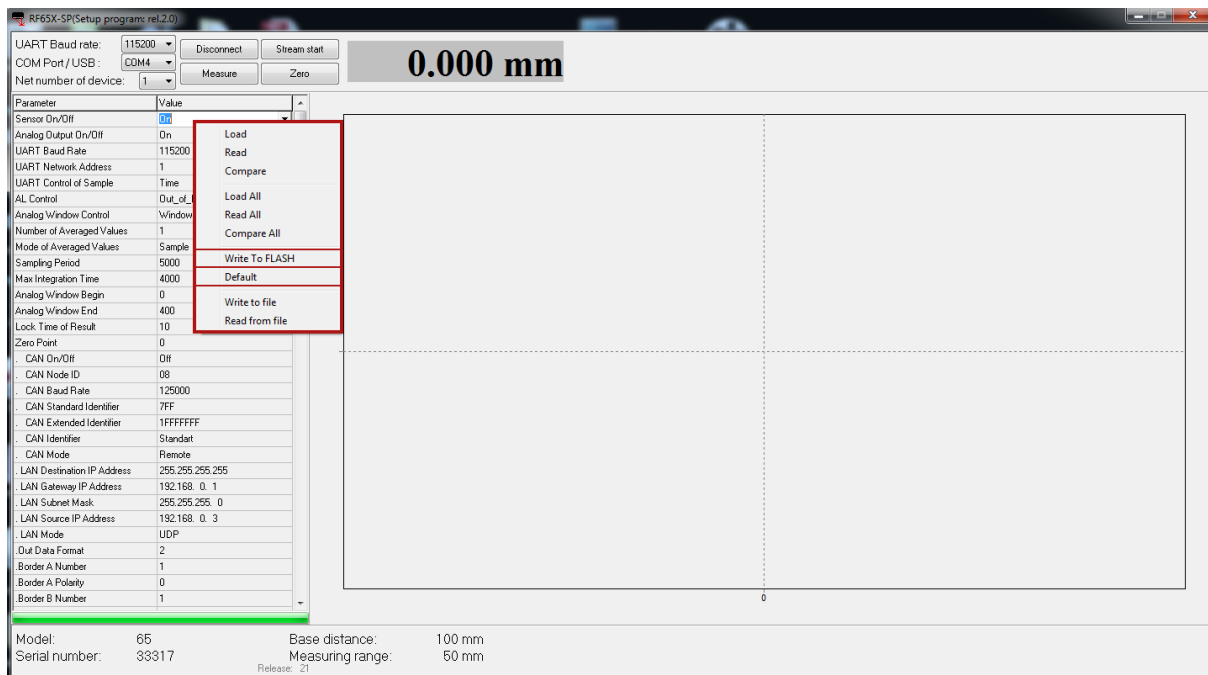

On success, the program will show the following message:

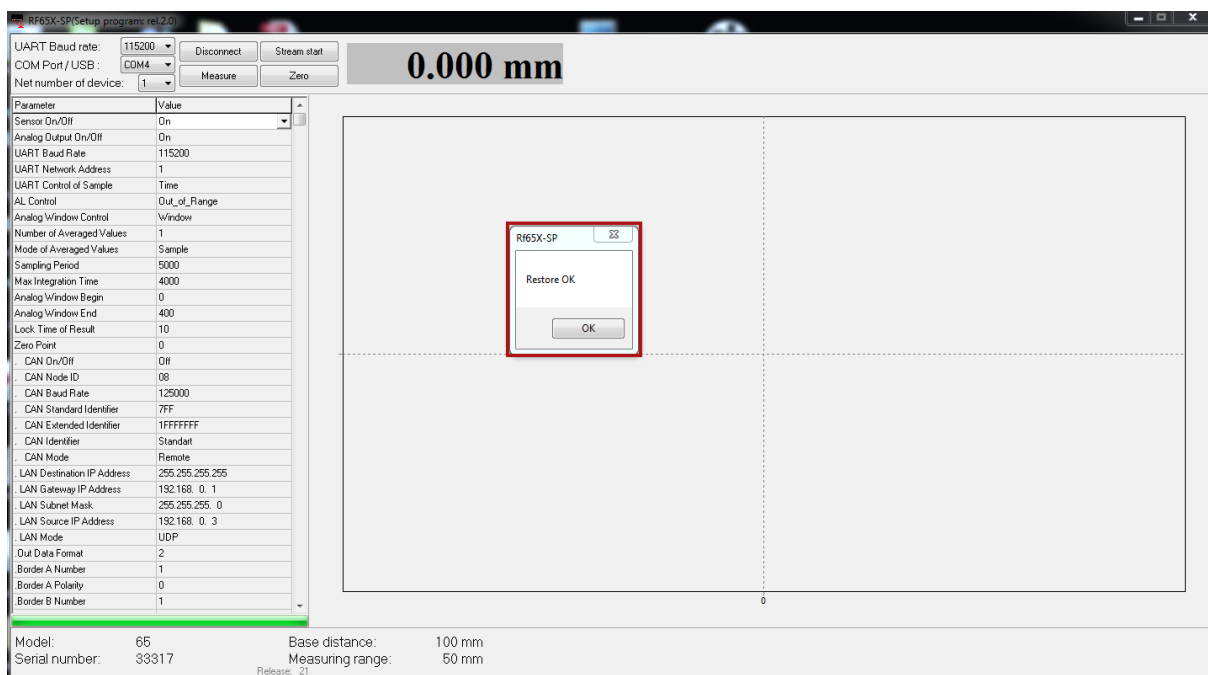

In order for the changes to take effect, you must end the connection session and reboot the micrometer by turning OFF/ON the power supply.

16.4. Setting the measurement modes

For more information about the measurement modes, please refer to par. [14.2.](#)(11h parameter) and par. [14.4.](#)

- Measurement of the position of one border (knife).

UART Baud rate: 115200 Disconnect Stream start
 COM Port / USB : COM4 Measure Zero
 Net number of device: 1

Parameter	Value
Analog Window Control	Window
Number of Averaged Values	1
Mode of Averaged Values	Sample
Sampling Period	5000
Max Integration Time	4000
Analog Window Begin	0
Analog Window End	100
Lock Time of Result	10
Zero Point	0
. CAN On/Off	Off
. CAN Node ID	08
. CAN Baud Rate	125000
. CAN Standard Identifier	7FF
. CAN Extended Identifier	1FFFFFFF
. CAN Identifier	Standart
. CAN Mode	Remote
. LAN Destination IP Address	255.255.255.255
. LAN Gateway IP Address	192.168. 0. 1
. LAN Subnet Mask	255.255.255. 0
. LAN Source IP Address	192.168. 0. 3
. LAN Mode	UDP
.Out Data Format	1
.Border A Number	1
.Border A Polarity	0
.Border B Number	1
.Border B Polarity	1
LOut Mask	0
LOut Down Limit	15000
LOut Up Limit	25000
Dia Correction	-1050
CulcDivCoef	50000

- Distance between borders A and B.
Finding the diameter of the object:

.Out Data Format	2
.Border A Number	1
.Border A Polarity	0
.Border B Number	1
.Border B Polarity	1

Finding the gap dimensions:

.Out Data Format	2
.Border A Number	1
.Border A Polarity	1
.Border B Number	1
.Border B Polarity	0

- The position of the object (a center of the object / gap).

.Out Data Format	3
.Border A Number	1
.Border A Polarity	0
.Border B Number	1
.Border B Polarity	1

17. Working with micrometer

- Place an object into the working range of micrometer.
- To get single result, press the **Measure** button.
- To get continuous data stream, it is necessary to set the synchronization mode and to press the **Stream start** button. The measurement result will be shown on the display.
- To reset dimensions of the object, press the **Zero** button. This mode is used to measure the deviation of the object from the specified size or position.

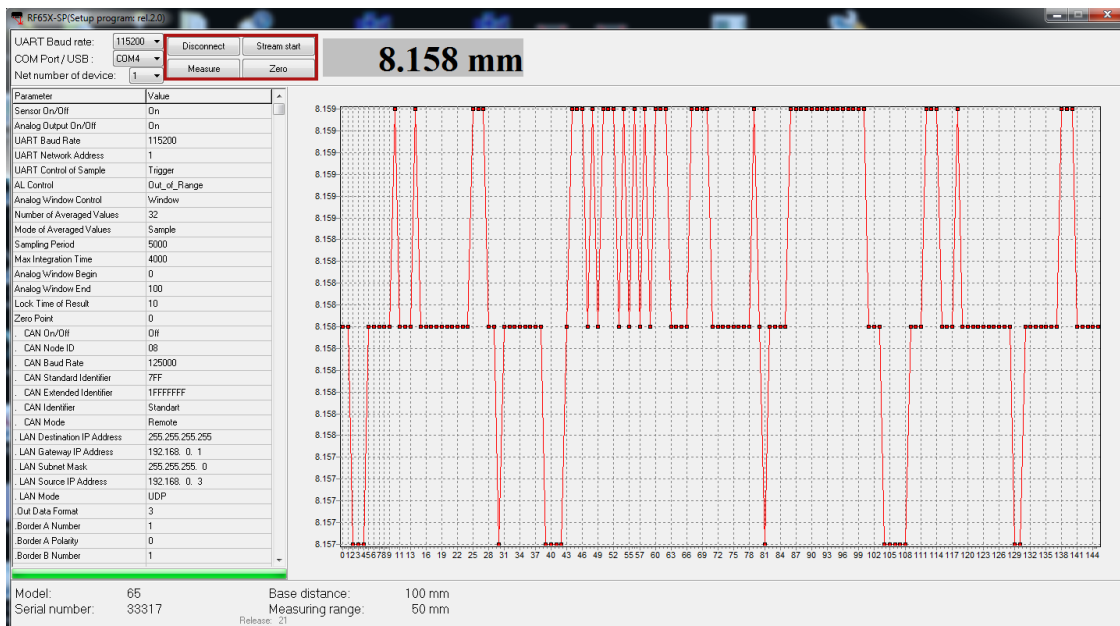

- To save all received data to a file, you need to press the right mouse key in the working area and select **Save data to file** in the pop-up window.
- It is possible to specify the position and zoom of the graph: selecting of the **Auto Scaling** option puts it into the active (passive) state that allows you to position and scale the graph automatically (manually).
- To clear the measurement field, it is necessary to select **Clear**.

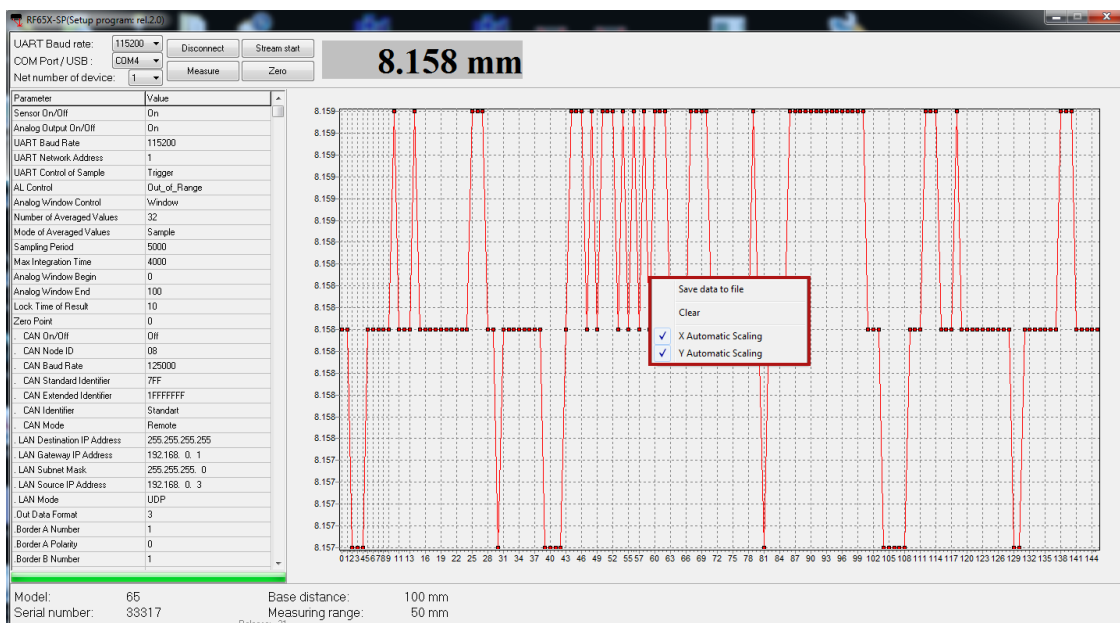

18. Examples of stream setting

18.1. Data transfer by request

Measurement data are transmitted on request from the PC:

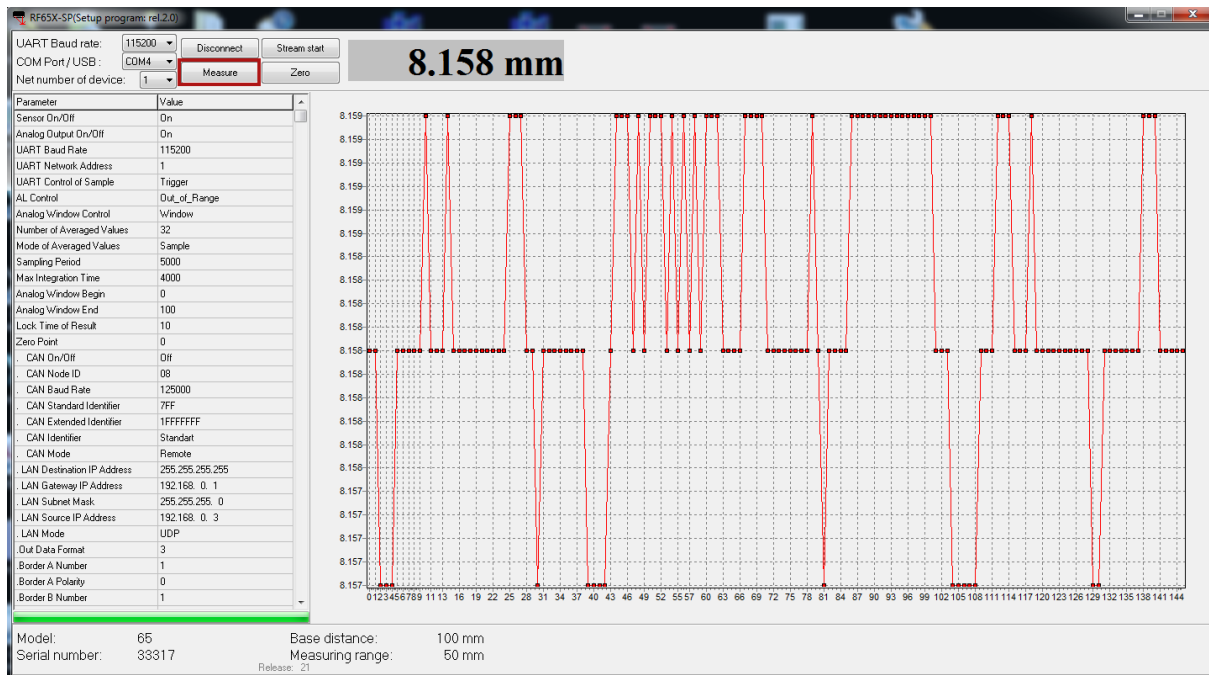

18.2. Synchronous data transfer

- Time Sampling

To work in this mode, you need to change 2 parameters: UART Control of Sample (to the Time mode) and Sampling Period (see p. 11.2).

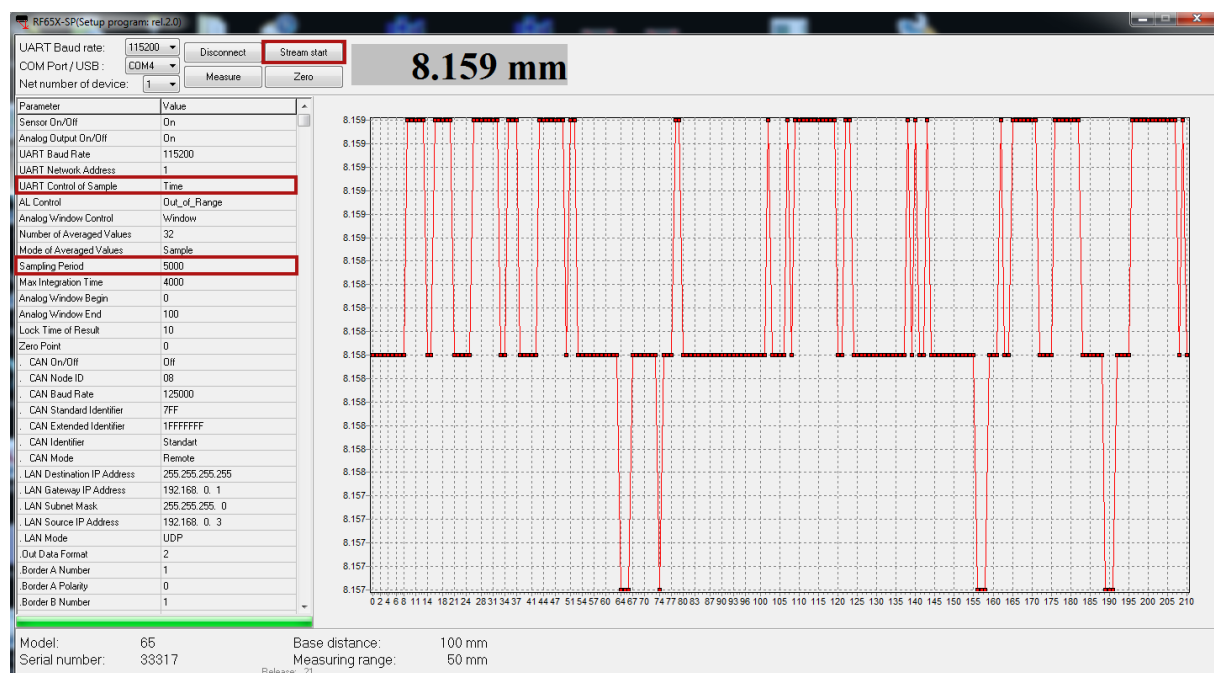

- Trigger Sampling

To work in this mode, you need to change 2 parameters: UART Control of Sample (to the Trigger mode) and Sampling Period.

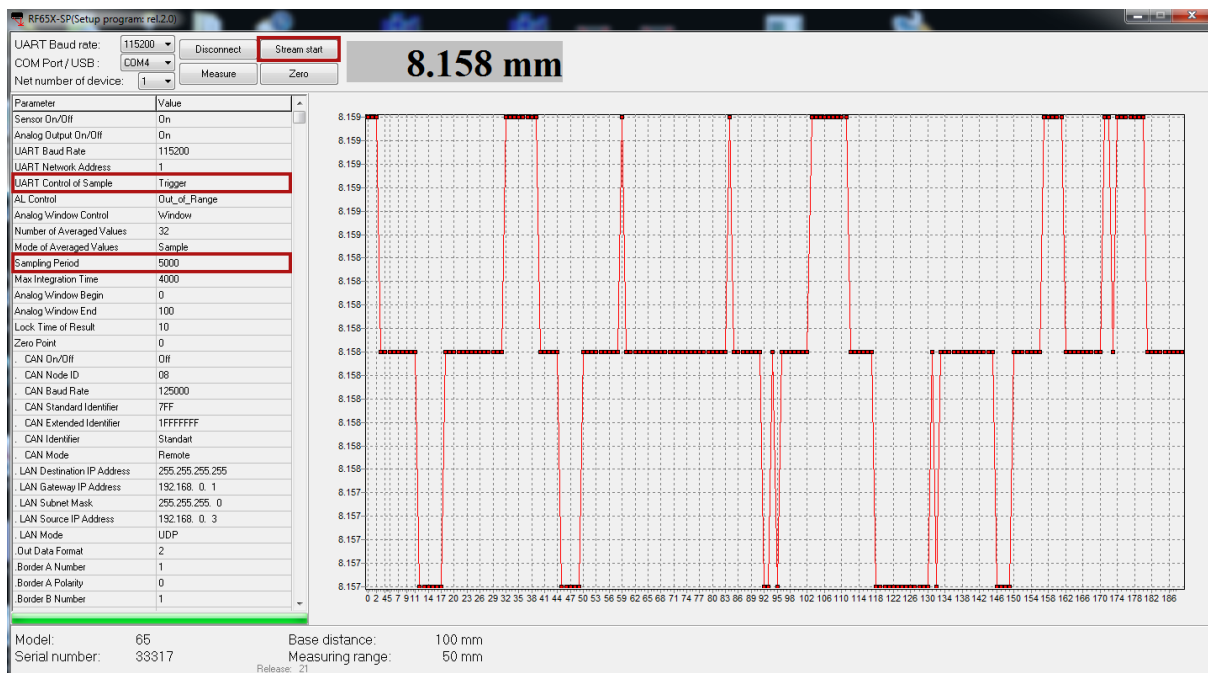

If you need to get results stream automatically after turn on the micrometer, make it's configuration and press **Write to FLASH** button.

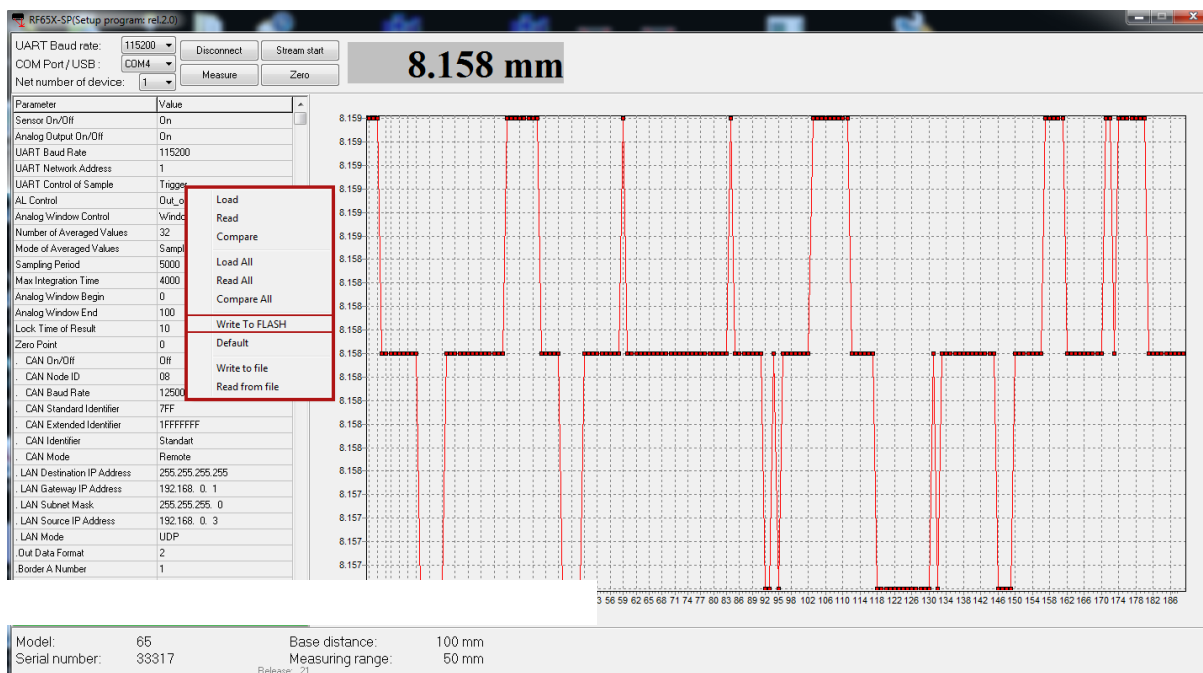

18.3. Setting the logical outputs

The following parameters are used for setting the logical outputs. The **LOut Mask** parameter sets the logic state: high active level or low active level. The **LOut Down Limit** parameter sets the lower trigger limit, and the **LOut Up Limit** parameter sets the upper trigger limit.

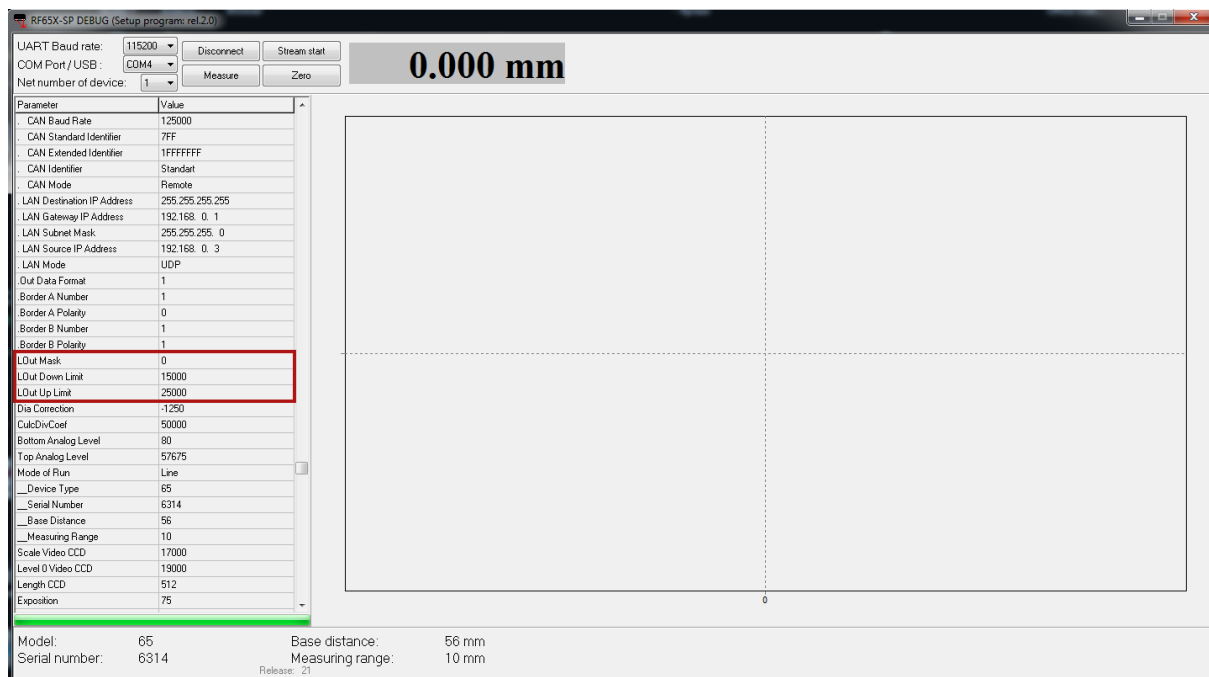

19. FDRF65X-SDK

Optical Micrometers are supplied together with SDK. The SDK allows the user to develop his own software products without going into details of the micrometer communications protocol.

20. Warranty policy

Warranty assurance for Optical Micrometers FDRF656 Series - 24 months from the date of putting in operation; warranty shelf-life - 12 months.