



mm PT9150

Description

- Linear Position to 550 inches (1400 cm)
- Aluminum or Stainless Steel Enclosure Options
- VLS Option To Prevent Free-Release Damage
- IP67 · NEMA 6 Protection



With its incremental optical encoder and industrial design this rugged transducer provides the highest accuracy and longest life of any measurement device of its kind. This model is available in a wide variety of resolutions and output stages to fit virtually any requirement.

It can measure up to 550", yet when its cable is retracted it is only 6" long. Its small size and low-cost-to-measurement ratio offers remarkable flexibility and value.

GENERAL

Full Stroke Range Options (on this datasheet)	0-75 to 0-550 inches
Output Signal Options	incremental encoder (quadrature)
Accuracy	0.04% full stroke (contact factory for higher accuracy)
Repeatability	± 0.02% full stroke ±1/2 pulse max.
Resolution Options	10 to 250 pulses per inch
Measuring Cable Options	stainless steel or thermoplastic
Enclosure Material	powder-painted aluminum or 303 stainless steel
Sensor	optical incremental encoder
Maximum Retraction Acceleration	see ordering information
Maximum Velocity	see ordering information
Weight, Aluminum (Stainless Steel) Enclosure	8 lbs. (16 lbs.) max.

ELECTRICAL

Input Voltage	see ordering information
Input Current	see ordering information

ENVIRONMENTAL

Enclosure	NEMA 4/4X/6, IP 67
Operating Temperature	0° to 160°F (-7° to 71°C)
Vibration	up to 10 g to 2000 Hz maximum

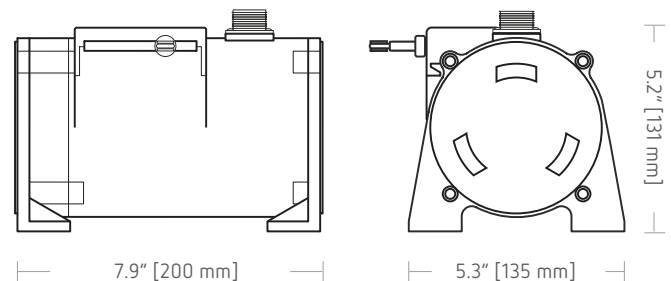

Output signal

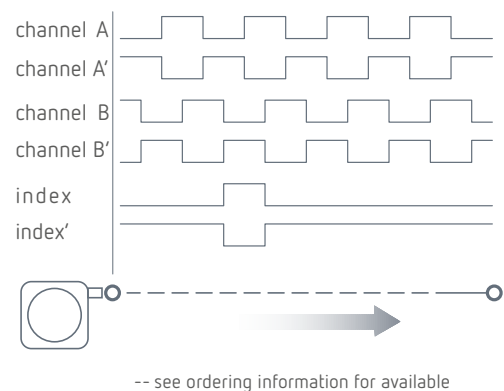
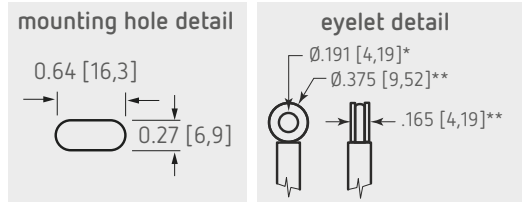
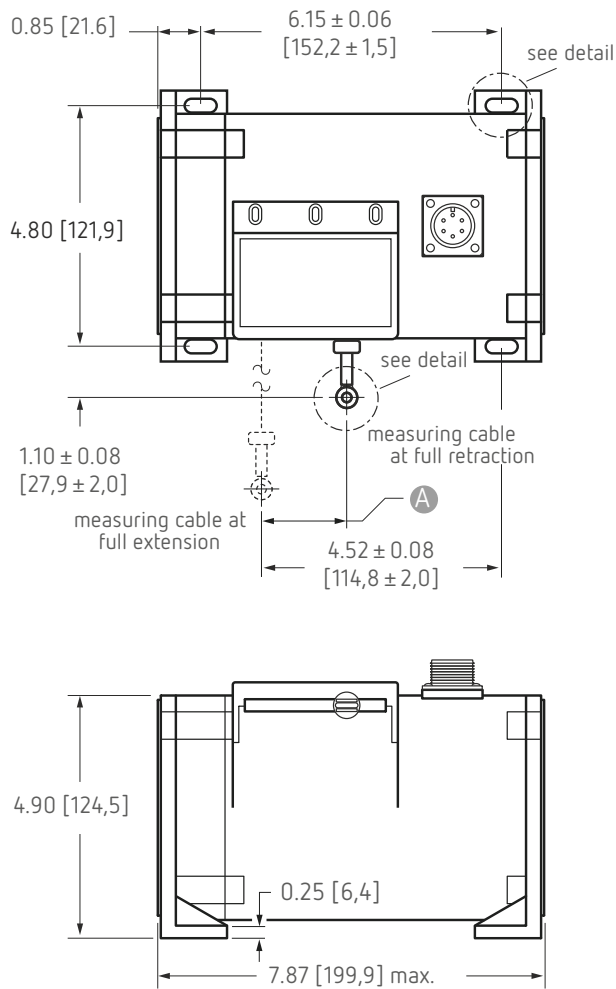
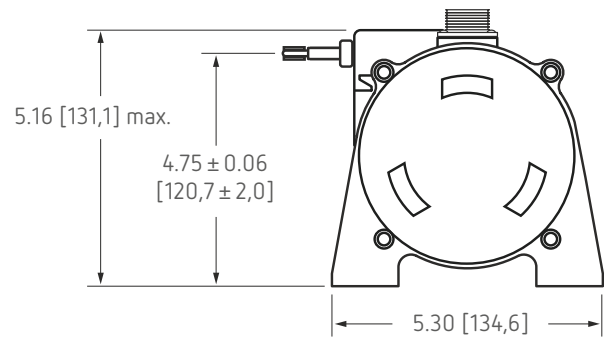

Fig. 1 – Outline Drawing (18 oz. cable tension only)



RANGE	A DIMENSION (INCHES)			
	MEASURING CABLE Ø.031 in.	Ø.034 in.	Ø.047 in.	Ø.062 in.
75	n/a	0.22	0.29	0.37
100	n/a	0.29	0.39	0.49
150	n/a	0.44	0.59	0.73
200	n/a	0.58	0.79	0.98
250	n/a	0.73	0.98	1.22
300	n/a	0.88	1.18	1.47
350	n/a	1.02	1.38	1.71
400	n/a	1.17	1.57	1.96
450	n/a	1.31	1.77	n/a
500	n/a	1.46	1.97	n/a
550	1.61	1.61	n/a	n/a



DIMENSIONS ARE IN INCHES [MM]
tolerances are 0.03 IN. [0.5 MM] unless otherwise noted.

* tolerance = +.005 - .001 [+ .13 - .03]
** tolerance = +.005 - .005 [+ .13 - .13]

Ordering Information

Model Number

PT9150- _____ **0**
order code: **R** **A** **B** **C** **D** **E** **F** **G**

Sample Model Number:

PT9150 - 0500 - 111 - 1110

- R** range: 500 inches
- A** enclosure/cable tension: aluminum/18 oz.
- B** measuring cable: .034 nylon-coated stainless cable front
- C** exit:
- D** output signal: TTL/CMOS driver r
- E** resolution: 100 ±2 pulses per inch electrical
- F** connection: 6-pin plastic connector

Full Stroke Range

english ranges

R order code:	0075	0100	0150	0200	0250	0300	0350	0400	0450*	0500*	0550*
full stroke range, min:	75 in.	100 in.	150 in.	200 in.	250 in.	300 in.	350 in.	400 in.	450 in.	500 in.	550 in.

metric ranges

R order code:	2500	3750	5000	6250	7500	8750	10000	11250	12500*	13750*
full stroke range, min:	2500 mm	3750 mm	5000 mm	6250 mm	7500 mm	8750 mm	10000 mm	11250 mm	12500 mm	13750 mm

* - 36 oz. cable tension strongly recommended

01.2016 | version 2016024 - Rev9

Ordering Information (cont.)

Enclosure Material and Measuring Cable Tension

A order code:	1	3	2	4
tension (±30%):	18 oz.		36 oz.	
enclosure material:	powder-painted aluminum	303 stainless steel	powder-painted aluminum	303 stainless steel
max. acceleration:	1 G	.33 G	5 G	2 G
max. velocity:	60 inches/sec	20 inches/sec	200 inches/sec	80 inches/sec

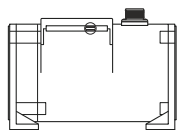

standard housing
see fig 1.

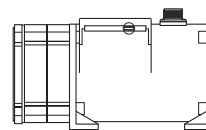

dual-spring housing
see fig 2.

Measuring Cable

B order code:	1	2	3	4
cable construction:	∅.034-inch nylon-coated stainless steel rope	∅.047-inch bare stainless steel rope	∅.058-inch PVC jacketed vectra fiber rope	∅.031-inch bare stainless steel rope
available ranges:	all ranges	all ranges up to 500 inches	all ranges up to 400 inches	550-inch range only
general use:	indoor	outdoor, debris, high temperature	high voltage or magnetic field	outdoor, debris, high temperature

Cable Exit

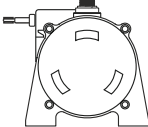
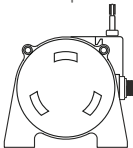
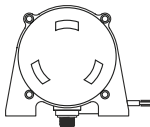
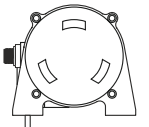
C order code:	1	2	3	4
	front	top	back	down
				

Output Signals

D order code:	1	2	3	4
output driver:	TTL - CMOS	Open Collector	5 V - Line Driver	Universal Line Driver
Input voltage (V+):	4.5...13.2 Vdc	10.8...26.4 Vdc	5 Vdc	5...28 VDC
Sink current:	20 mA max.	20 mA max.	20 mA max.	20 mA max.
Input current:	80 mA max.	80 mA max.	150 mA max.	100 mA max, no load

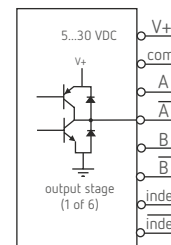
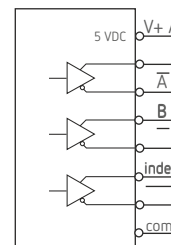
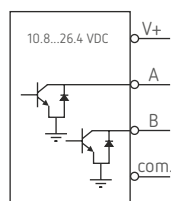
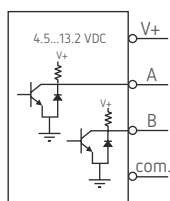

Resolution

E order code:	1	2	3	4
english ranges:	100 ±2 pulses per in.	200 ±4 pulses per in.	250 ±5 pulses per in.	10 ±0.2 pulses per in.
metric ranges:	5 ±0,1 pulses per mm	10 ±0,2 pulses per mm	12,5 ±0,25 pulses per mm	0,5 ±0,01 pulses per mm

Ordering Information (cont.)

Electrical Connection

Order code: **1** **2** **3** **4**

6-pin plastic connector with mating plug
IP 67, NEMA 4X*,6

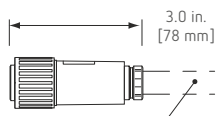

.30 - .39 in. [8 - 10 mm] cable dia.
16 AWG max conductor size
connector: MS3102E-14S-6P mating
plug: MS3106E-14S-6S

25-ft. instrumentation cable
24 AWG, shielded
IP 67, NEMA 6



25 ft. x 0.2-in. dia.
[7,5 M x 5 mm dia.]
24 AWG, shielded

18-pin plastic connector with mating plug
IP 65, NEMA 4

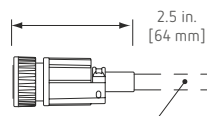

.26 - .30 in. [6,6 - 7,6 mm] cable dia.
20 - 24 AWG conductor size connector:
Conxall 14282-18PG-300-K mating
plug: Conxall 13282-18SG-326-K

6-pin metal connector with mating plug
IP 67, NEMA 6

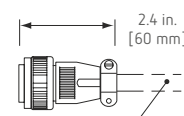

3/8-in. [9 mm] max cable dia.
16 AWG max conductor size
connector: MS3102E-14S-6P
mating plug: MS3106E-14S-6S

6-pin mating plug:

	TTL/CMOS Open Collector	5 V Line Driver pin Universal Line Driver
A	input voltage	input voltage
B	common	common
C	channel A	channel A
D	channel B	channel B
E	-	channel A'
F	-	channel B'

contact view



18-pin mating plug:

	TTL/CMOS Open Collector	5 V Line Driver pin Universal Line Driver
1	input voltage	input voltage
2	common	common
3	channel B	channel B
6	channel A	channel A
7	-	index
11	-	channel B'
12	-	channel A'
15	-	index'

contact view



25-ft. instrumentation cable:

	TTL/CMOS Open Collector	5 V Line Driver color Universal Line Driver
red	input voltage	input voltage
black	common	common
green	channel A	channel A
white	channel B	channel B
blue	-	channel A'
brown	-	channel B'
yellow	-	index
orange	-	index'

* - applies to stainless steel enclosure only.

VLS Option - Free Release Protection

The patented Velocity Limiting System (VLS) is an option for PT9000 Series cable extension transducers that limits cable retraction to a safe 40 to 55 inches per second for the single spring option and 40 to 80 inches per second for the higher tension dual spring option.

The VLS option prevents the measuring cable from ever reaching a damaging velocity during an accidental free release. This option is ideal for mobile applications that require frequent cable disconnection and reconnection. It prevents expensive unscheduled downtime due to accidental cable mishandling or attachment failure.

How To Configure Model Number for VLS Option:

VLS9150 - - - - - - -

creating VLS model number (example)...

1. select PT9150 model
2. remove "PT" from the model number
3. add "VLS"
4. completed model number !

PT9150-0100-111-1110
~~PT~~9150-0100-111-1110
 VLS + 9150-0100-111-1110
 VLS9150-0100-111-1110

Fig. 2 – Outline Drawing (36 oz. cable tension only)

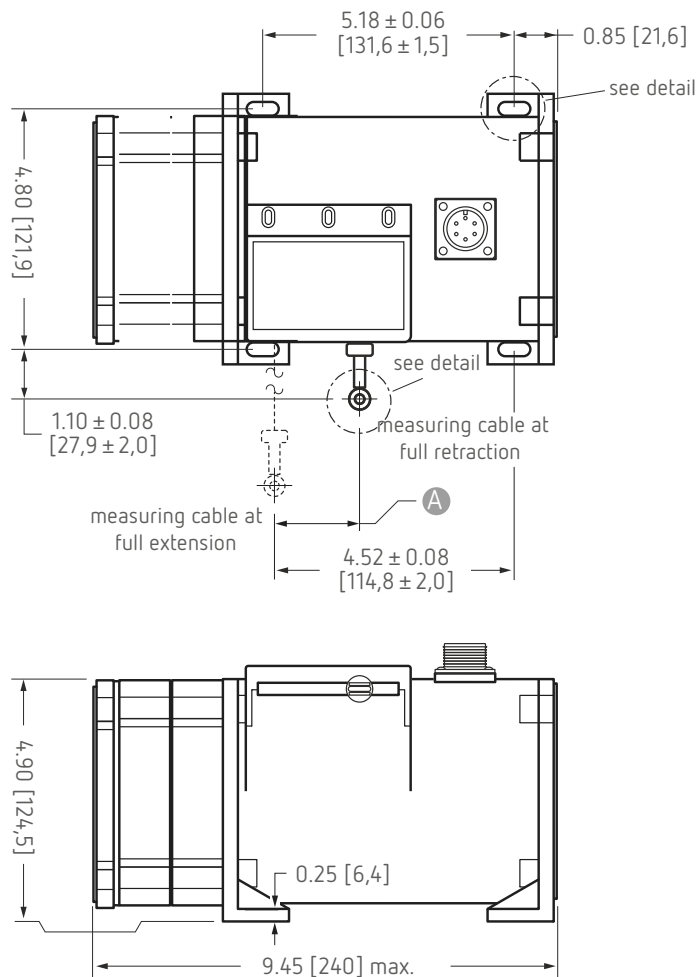

mounting hole detail

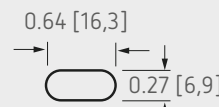

eyelet detail

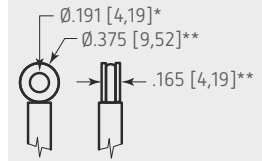

A DIMENSION (INCHES)

RANGE	MEASURING CABLE			
	Ø.031 in.	Ø.034 in.	Ø.047 in.	Ø.062 in.
75	n/a	0.22	0.29	0.37
100	n/a	0.29	0.39	0.49
150	n/a	0.44	0.59	0.73
200	n/a	0.58	0.79	0.98
250	n/a	0.73	0.98	1.22
300	n/a	0.88	1.18	1.47
350	n/a	1.02	1.38	1.71
400	n/a	1.17	1.57	1.96
450	n/a	1.31	1.77	n/a
500	n/a	1.46	1.97	n/a
550	1.61	1.61	n/a	n/a

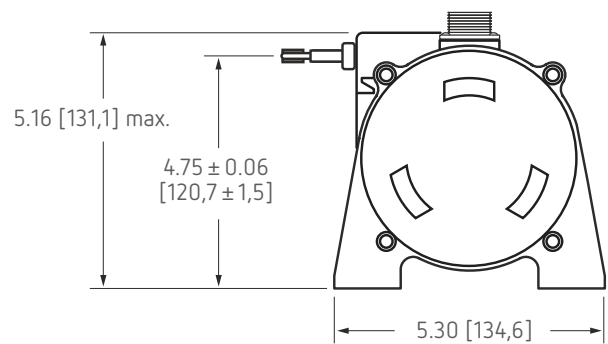

DIMENSIONS ARE IN INCHES [MM]
tolerances are 0.03 IN. [0.5 MM] unless otherwise noted.

* tolerance = +.005 - .001 [+.13 -.03]
** tolerance = +.005 - .005 [+13 -.13]