



**mm SR1V**

175-inch model shown

**Description**

- User Adjustable Stroke Range to 175 inches (3 meters)
- User Selectable 0–5, 0–10, –5–+5, –10–+10 VDC Output
- Designed for Outdoor & IP67 environments
- In Stock for Quick Delivery!



The SR1V is part of a series of rugged, low-cost, high performance string pots built for wet environments and outdoor applications. Designed for the rigors of outdoor construction equipment or the demands of a factory floor, the SR1M is the perfect low-cost solution for OEM and stocking distributors.

What sets this sensor apart from other string pots, is the internal programmable digital circuitry that gives the customer a one-size-fits-all approach for many applications. The SR1V ships factory calibrated to the full stroke range but the output signal can be easily re-scaled to match any stroke down to 1 inch (25 mm).

**SPECIFICATIONS**

Full Stroke Range, FDSR1V-125	125 inches (3175 mm), maximum
Full Stroke Range, FDSR1V-175	175 inches (4445 mm), maximum
Minimum Full Stroke Range	1 inches (25 mm)
Output Signal Settings	0–5, 0–10, –5–+5, –10–+10 VDC
Input Voltage	15-30 VDC (10-30 VDC for 0–5, –5–+5 volt signal)
Input Current	50 mA, max.
Maximum Output Load	20 mA
Accuracy, full stroke range ≥ 10 inches (254 mm)	.5% FS.
Accuracy, full stroke range < 10 inches (254 mm)	consult factory
Repeatability	.1% FS.
Resolution	.0015% FS.
Output Signal Update Rate	1 msec
Maximum Velocity	80 inches (2 meters) per second
Maximum Acceleration	10 g (retraction)
Measuring Cable Tension	23 oz. (6,4 N) ±30%
Sensor	plastic-hybrid precision potentiometer
Cycle Life	250,000 (potentiometer)
Enclosure	polycarbonate
Measuring Cable	.034-inch dia. nylon-coated stainless
Electrical Connection	M12 Connector (mating plug included)
Environmental Suitability	NEMA 6, IP67
Operating Temperature	[–40° to 185° F (–40° to 85° C)
Weight	2.5 lbs. (1.3 Kg)

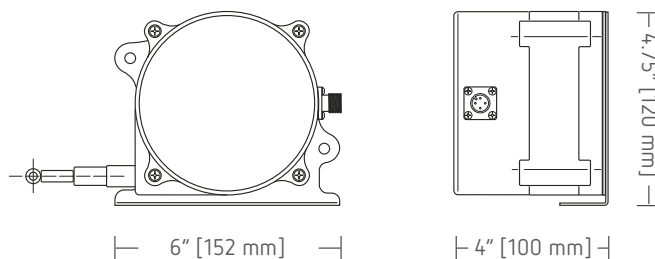

**Ordering information**

Order No. <b>SR1V-125</b> 125-inch stroke range, 0–10 Vdc output, 4-pin M12 mating plug & mounting bracket included.	Order No. <b>SR1V-175</b> 175-inch stroke range, 0–10 Vdc output, 4-pin M12 mating plug & mounting bracket included.	Order No. <b>9036810-0040</b> for short-run connections, optional 13-ft cordset with 4-pin M12 mating plug.

**Output signal**

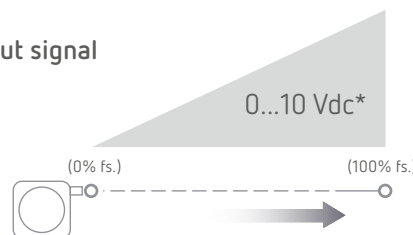

\*Additional Output Options: 0...5, –5...+5, –10...+10 Vdc

## Electrical Connection

output signal	connector pin	colorcode (cordset)
15...30 vdc	1	brown
output signal	2	white
common	3	blue
n/c	4	black

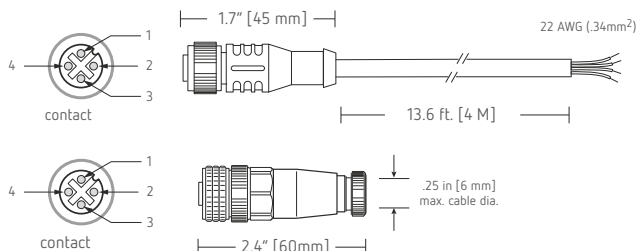

## Factory Calibrated Stroke Range

The full scale output signal is set at the factory to the maximum full stroke range. The ZERO point (output = 0 Vdc) is set at the beginning\* of the stroke range (0 inches) and the SPAN point (output = 10 Vdc) is set to the end of the range (125 inches or 175 inches depending on model).

\*Important — The ZERO point is set at the factory with the measuring cable pulled out .125 inches from full retraction.

This is for the factory setting only and the ZERO may be reprogrammed at full retraction at any time.

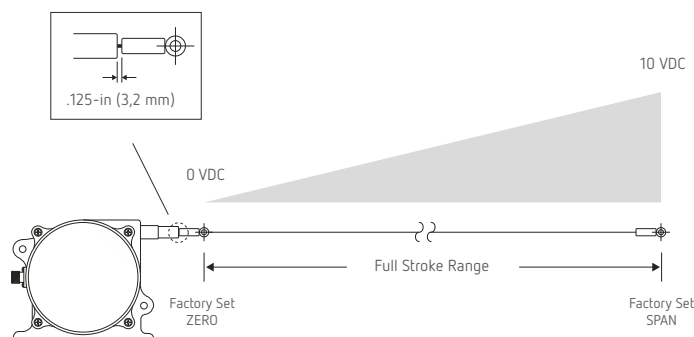

## Changing the Cable Exit

### Changing Measuring Cable Exit

To change the direction of the measuring cable, remove the 4 mounting bracket screws and rotate bracket to one of four available positions. See figures 1 - 4 on the following pages for mounting dimensions.

### Changing Electrical Connector Direction

To change the position of the electrical connector, remove the 4 rear cover screws and carefully separate rear cover from the sensor body.

Rotate the rear cover to desired position being careful to not tangle the wiring harness that runs to the connector.

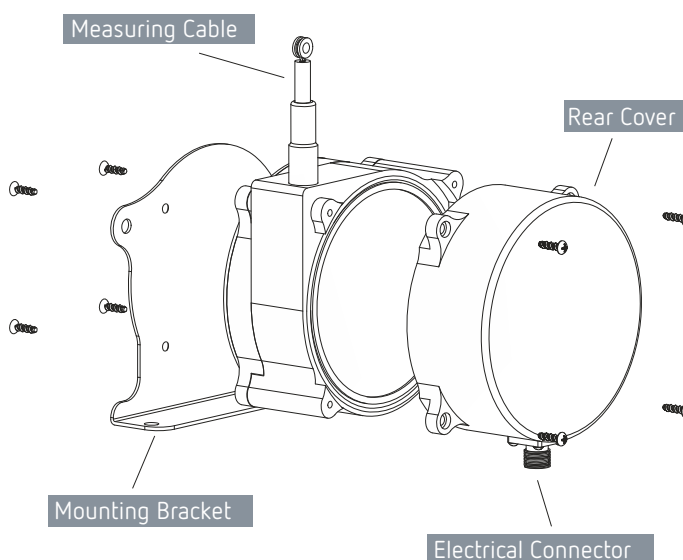

## Cable Exit Direction Options

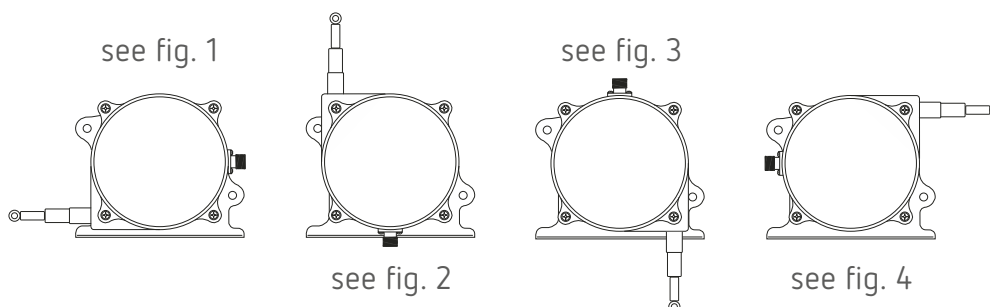

## Internal Controller Board

to gain access to the controller board, remove the four phillips screws and remove rear cover.

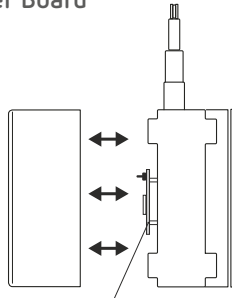

zero/span pushbutton and signal selection switches located on controller board

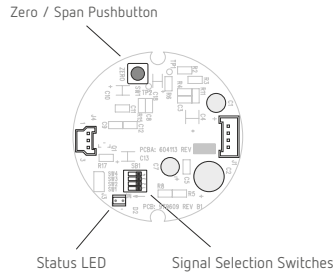

Status LED		
green	red	
on	—	power on, output signal within programmed limits
on	flashing	output signal below zero setting
flashing	on	output signal beyond span setting

## Changing Output Signal

### Reprogramming ZERO and SPAN:

Though ZERO and SPAN points have been preset at the factory, they can easily be changed to match any desired stroke within the full stroke limits of the sensor. To reprogram the FDSR1V to your own settings, remove the rear cover to gain access to the internal controller board. Locate the push-button on the circuit board and follow the instructions below.

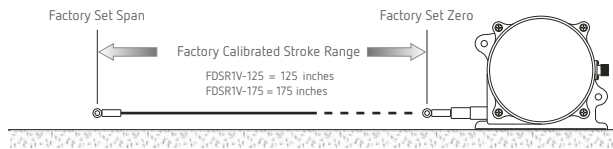

Please note that ZERO and SPAN points can be set independently. You can set one without setting the other. This operation must be performed with the sensor under power. Important: when you are finished, disconnect power for a couple of seconds to permanently set your new settings.

### Setting Span:

Set the cable to the desired SPAN limit then depress and hold the button until the STATUS LED begins to flash RED. Release the button (when the LED is flashing RED, not GREEN) and the flashing will slow down to about two-second intervals which indicates the SPAN value is being set into memory. When completed, the STATUS LED will display solid GREEN.



### Setting Zero:

Set the cable to the desired ZERO limit and then depress and hold the button until the STATUS LED begins to flash GREEN. Release the button (when the LED is flashing GREEN, not RED) and the flashing will slow down to about two-second intervals which indicates the ZERO value is being set into memory. When completed, the STATUS LED will display solid GREEN. Remove power for 2 seconds then reconnect.



## Changing the Output Signal:

		switch settings			
		SW1	SW2	SW3	SW4
output signal options (VDC)	zero ... span	off	off	off	off
	0 ... 5	on	off	off	off
	5 ... 0	off	off	off	on
	0 ... 10	on	off	off	on
	10 ... 0	off	off	on	off
	-5 ... +5	on	off	on	off
	+5 ... -5	off	on	off	off
	-10 ... +10	on	on	off	off
+10 ... -10	off	off	on	on	

The SR1V leaves the factory set with a 0...10 VDC full scale output signal. The signal can be reversed or changed to either 0...5, -5...+5 or -10...+10 VDC (see illustration) by simply changing a dipswitch located on the controller board.

If you wish to simply reverse the output signal or change it to a different voltage range, you may do so without resetting the "zero" and "span" points.

Remove the rear cover to gain access to the board.

Fig. 1 - Outline Drawing (as shipped)

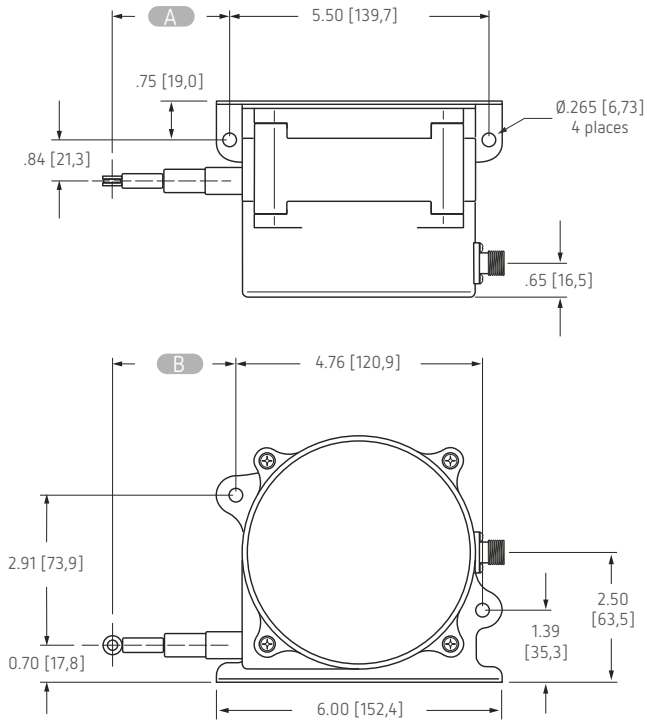

Model	A	B
125-inch	2.00 ± .13 [50,8 ± 3,3]	2.37 ± .13 [60,22 ± 3,3]
175-inch	2.87 ± .13 [72,8 ± 3,2]	3.24 ± .13 [82.2 ± 3,2]

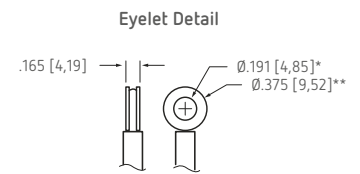
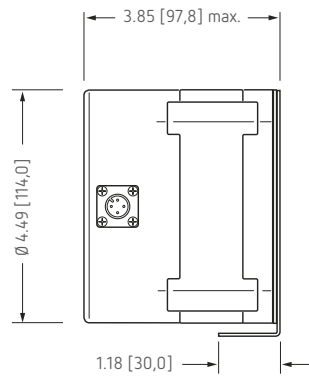
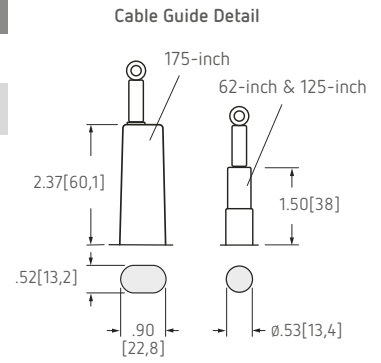

units are in inches [mm] tolerances are ± .04 [1,0] unless otherwise noted

\* tolerance = +.005 - .001 [+13 - .03]  
\*\* tolerance = +.005 - .005 [+13 - .13]

Fig. 2 - "Up" Cable Exit Direction

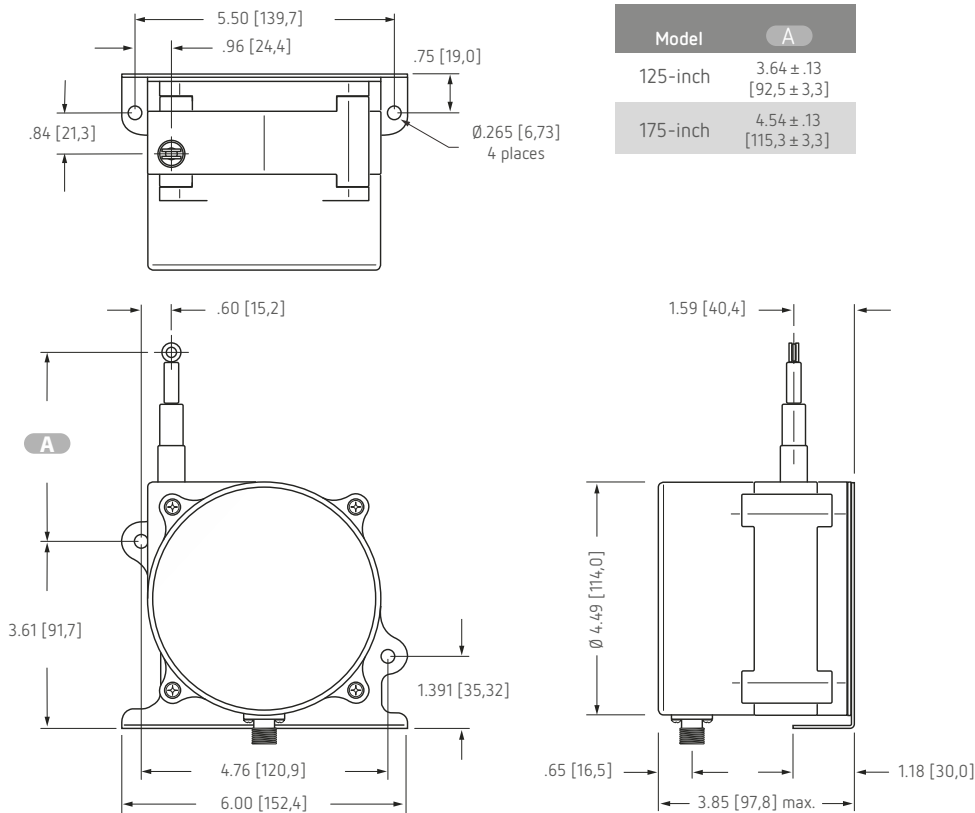

Model	A
125-inch	3.64 ± .13 [92,5 ± 3,3]
175-inch	4.54 ± .13 [115,3 ± 3,3]

Fig. 3 - "Down" Cable Exit Direction

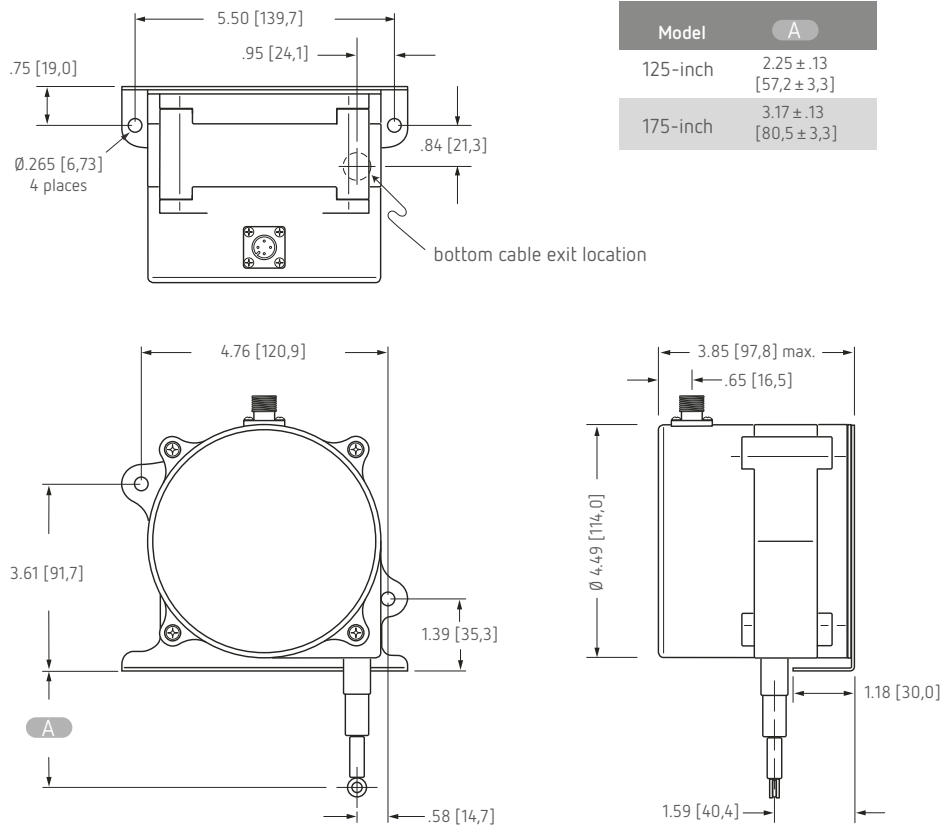
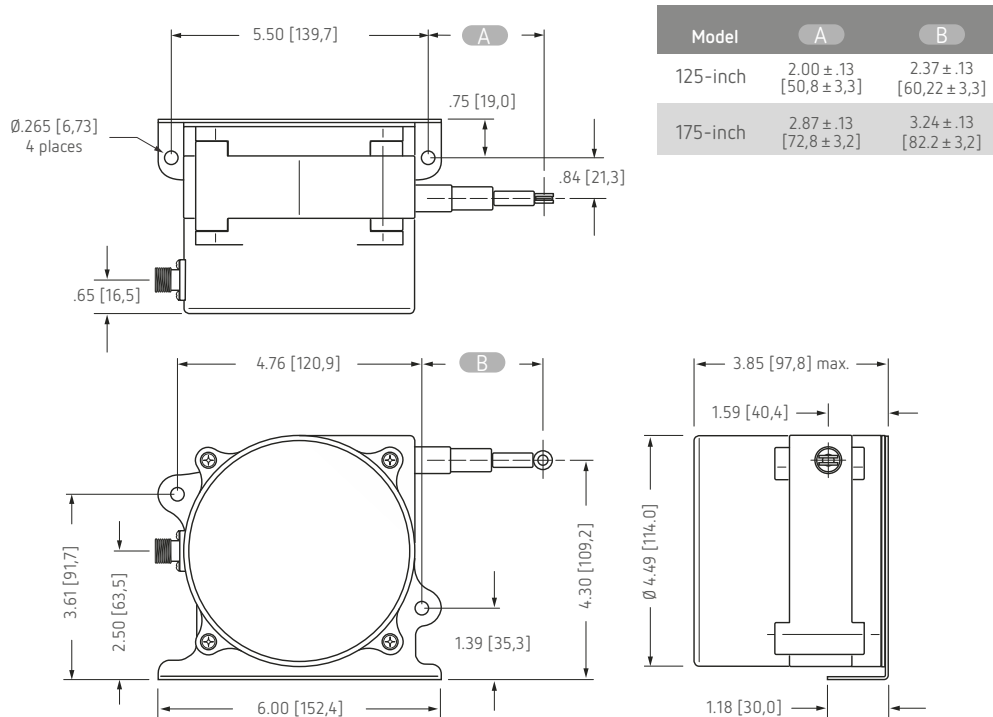

Fig. 4 - "Rear" Cable Exit Direction



units are in inches [mm] tolerances are ± .04 [1,0] unless otherwise noted

The information provided herein is to the best of our knowledge true and accurate, it is provided for guidance only. All specifications are subject to change without prior notification.

Althen – Your expert partner in Sensors & Controls | [althensensors.com](http://althensensors.com)

Althen stands for pioneering measurement and custom sensor solutions. In addition we offer services such as calibration, design & engineering, training and renting of measurement equipment.

Germany/Austria/Switzerland  
[info@althen.de](mailto:info@althen.de)

Benelux  
[sales@althen.nl](mailto:sales@althen.nl)

France  
[info@althensensors.fr](mailto:info@althensensors.fr)

Sweden  
[info@althensensors.se](mailto:info@althensensors.se)

USA/Canada  
[info@althensensors.com](mailto:info@althensensors.com)

Other countries  
[info@althensensors.com](mailto:info@althensensors.com)