

Single Channel Strain Gauge Amplifier

SG-INL-12E/24E-xxx



Content

■ 1 General Information	3
■ 1.1 Safety Instructions	3
■ 1.2 Qualified Personnel	3
■ 1.3 Intended Use	3
■ 2 Instructions for use of the measuring amplifier	4
■ 2.1 Instructions for use of strain gauge sensors	4
■ 3 Technical description	5
■ 4 Terminal Assignment	5
■ 4.1 Supply voltage	6
■ 4.1.1 Galvanic Isolation	6
■ 4.2 Strain gauge excitation voltage	6
■ 4.3 Analogue output	7
■ 4.3 Analogue output voltage	7
■ 4 Starting up	8
■ 5.1 Zero point adjustment range	8
■ 5.2 Adjustment / calibration of the amplifier	9
■ 5.2.1 Calculation of amplification determining resistor	10
■ 6 Maintenance	11
■ 7 Old appliances disposal	11
■ Appendix	12
■ Datasheet	12
■ Order designation	12
■ Component diagram	13
■ Housing dimensions	14

■ 1 General Information

To ensure reliable and safe operation, the measuring amplifier must be operated in compliance with the specifications according to this technical description only. These regulations must also be observed if accessories, that have been ordered from Althen Mess- & Sensortechnik GmbH together with the measuring amplifier being used.

Notice: Every person who is in charge for the start-up or service of this measuring amplifier must have read this technical manual and must have understood the safety instructions in particular.

■ 1.1 Safety Instructions

When using the amplifier, the legal- and safety regulations for each case of application must be observed. To avoid risks for the system or the operator the following points are to be considered.

- If any visual damage or malfunctions are noticed, the measuring system must be switched off and marked appropriately.
- Disconnect the supply voltage before opening the device.
- The complete measuring unit must be protected against contact and influence of unauthorized persons.
- In the case of a safety-relevant application, where a potential malfunction could cause damage to property or persons, it is imperative that an additional, independent monitor is provided.
- In combination with sensors, the maximum loads / pressures etc. must never be exceeded.

If you have reasons to assume that safe operation is no longer possible, immediately take the device out of operation and secure it against unintentional operation.

■ 1.2 Qualified Personnel

This measuring system must be operated by qualified personnel and in compliance with the relevant technical specifications only. Qualified personnel include such persons who are conversant with the setting up, mounting and starting up of the measuring system and who have qualifications that are appropriate for the tasks they're about to perform.

■ 1.3 Intended Use

Amplifiers from Althen Mess- & Sensortechnik GmbH serve to measure the intended measurand and the evaluation thereof in combination with one or more sensors. Any other use over and above that is regarded as non-intended use.

■ 2 Instructions for use of the measuring amplifier

Notice: The parameterizations, further information concerning the scaling as well as the customized analogue output can be found on the additional sheet "Device-Configuration".

Since this amplifier is a highly sensitive measurement technology product, it must be used for its intended use as well as the described operating conditions only. Initial start-up and changes in setup and settings must be done by qualified personnel only. To prevent interventions / modifications made by unauthorized personnel, suitable measures must be taken. Both function and calibration must be checked regularly.

The amplifier must be operated with a separate power source used for measurement devices only. The EMC-installation instructions must be complied with. The amplifier must be connected to clean earth-potential. To avoid possible potential equalization currents over the shield of the cable to the following evaluation unit, this shield should be connected over a suitable capacitor (10nF/200V). In order to not increase the interference sensitivity of the amplifier, all cables should be kept as short as possible and should not be extended. Possible cable-bound interferences (i.e. noise) must be blocked very near the cable ends (evaluation unit) by suitable measures.

If it is to be expected that the amplifier is, as example, cleaned with a high-pressure cleaner/ steam jet an additional protection shall be provided.

Notice: Changes of the amplifier of any kind demands for the explicit approval of Althen Mess- & Sensortechnik GmbH. Changes of any kind done without that approval exclude all possible warranty and/or liability of Althen Mess- & Sensortechnik GmbH.

■ 2.1 Instructions for use of strain gauge sensors

Notice: Strain gauge sensors with a small range are extremely sensitive to improper handling. Force transducers can be destroyed simply by touching. Same applies for the diaphragms of pressure transducers. So, bear in mind: handle with care!

Loading the transducer in excess of the nominal range may result in an increased and lasting zero balance offset as well as damage to the sensor. The same applies to short-term force or pressure impulses that exceed the nominal range.

To most force transducers the force must be applied centrally in order to avoid shear forces, that may be harmful to the sensor, or may cause measurement inaccuracy. Centric force transmission can be ensured by rounded surfaces, joint heads or other suitable guides.

Tightening torques while mounting any sensors may result in an increased zero balance offset.

If the sensor has been replaced, the calibration of the amplifier must be checked. A new adjustment might be necessary.

■ 3 Technical description

The described single-channel measuring amplifier is contained in a robust aluminum die-cast housing (IP20), serves to supply a strain gauge sensor with a full bridge resistance of 300 ohms or more and the amplification of the sensors signal.

The supply voltage of the amplifier is galvanically isolated from analogue output, sensor supply and sensor signal.

The circuitry is in 4-wire technology. Standard analogue outputs (0 ... 10 V or ± 10 V) are available for further evaluation. The amplifier is built in a robust aluminum die cast housing, which is suited for rough and industrial environment.

The coarse amplification is determined by an internal resistor and can be fine adjusted by a potentiometer. After opening the lid, the potentiometer mentioned before as well as the potentiometer for zero-adjustment allow a correction of the calibration. If the range for adjusting the zero-point should not be sufficient, an internal resistor (R-4) can be soldered in to add a tare. In addition, the solder point (LP-2) has to be set to + or -, corresponding to the tare-load.

■ 4 Terminal Assignment

The electrical connections are made on the supply and analogue output side with a cable 3 meters of length and open cable ends and on the sensor side via a binder connector. Either series 712 or 423, depending on the cables diameter which comes with the sensor.

cable		connector	
cable color	description	PIN	description
<i>white</i>	+Supply voltage (+Ub)	<i>1</i>	+ Excitation
<i>brown</i>	Supply ground (Ub)	<i>2</i>	- Excitation
	<i>Galvanic isolation</i>	<i>3</i>	+ Signal
<i>yellow</i>	Analogue output (0 ... +10 V or. ± 10 V)	<i>4</i>	- Signal
<i>green</i>	Analogue output ground	<i>5</i>	n.c.

Supply ground and analogue ground are isolated galvanically. To unset this isolation the jumper JP2 has to be changed.

■ 4.1 Supply voltage

The supply voltage is with version -24E in the range of 18 to 30 VDC and with version –E12 within 10 to 18 VDC. The presence of the supply/ internal operating voltage is indicated by a green LED through the lid.

To protect the electronics an (to the supply voltage version corresponding) internal self-healing “polyswitch-resettable®” fuse is built in. Whether an external additional fuse is necessary is to be checked. However, an additional external fuse of 0,2 A is recommended.

If the indicator LED goes off, the supply voltage and possibly existing external protection has to be checked.

Notice: While switch-on the amplifier it is capacitive. Thus, the switch-on current is greater than the operating current. This must be taken into consideration when dimensioning and selecting the power pack, especially if several amplifiers are being wired to the same power source.

■ 4.1.1 Galvanic Isolation

Supply ground and analogue ground are isolated galvanically. To unset this isolation the jumper JP2 has to be changed.

■ 4.2 Strain gauge excitation voltage

The described measuring amplifier is able to supply one strain gauge transducer. Any strain gauge full bridge with a bridge resistance of 300 ohms or more may be connected. The transducer can be supplied with either 2,5 V, 5 V, or 10 V unipolar voltage. This value can be selected by a solder point (LP-3-1).

LP-3-1	LP-3-2	LP-3-3	excitation
set	not set	not set	10 VDC
not set	set	not set	5 VDC
not set	not set	set	2,5 VDC

■ 4.3 Analogue output

The following standardized analogue outputs, depending on the ordered option, are available:

Version ...010:

The output is: 0 ... +10 Volts (max 1 mA)

Version ...B10:

The output is: ± 10 Volts (max 1 mA)

Other analogue outputs available on request. For parameter settings, further information concerning scaling, or customized analogue outputs, please refer to the additional sheet "Allocation / Device Configuration).

■ 4.3 Analogue output voltage

The analogue voltage output can be picked up on the corresponding clamps. See chapter 4 "Terminal Assignment".

In combination with a transducer which is capable to handle tension and compression forces an analogue output of ± 10 volts is available. But if an unipolar voltage is needed it is possible to set the zero point of the transducer to 5 volts of the output.

■ 5 Starting up

If an adjustment (A-K-1K / A-D-1K) has been ordered in combination with the amplifier(-s) and/or transducers(-s) it may be necessary for a slight fine adjustment nonetheless. This is due to possible various environmental influences as well as to mounting etc.

If any visual damage or malfunctions are noticed, the measuring system must be switched off and marked appropriately.

- Mounting transducer and amplifier
- Connect transducer to the amplifier
- Connect multimeter to analogue output
- Connect supply voltage – consider pin assignment
- Allow the system about 30 min. to warm up
- Check function and calibration of the system

Notice: The allocation of transducer / amplifier is to be complied with. After replacing a transducer, the calibration has to be checked.

It is to be noted that there is a slight dependence between zero-point adjustment and amplification (gain).

■ 5.1 Zero point adjustment range

It is to be noted that there is a slight dependence between zero-point adjustment and amplification (gain).

The zero-point adjustment range is approx. $\pm 15\%$.

■ 5.2 Check / adjustment of the amplifier

In order to adjust or calibrate the amplifier a multimeter has to be connected to the analogue output.

Functional Check:

- Unload the measuring device.
- Connect the multimeter (refer to chapter 4 "Terminal Assignment").
- Set the analogue output to 0 Volts.
- Load the measuring device (i.e. the transducer) at least 3 times with its maximum load.
- Load the device with 80 % of its maximum load.
- Check if the analogue outputs complies with the load and is within the designated specs.
- If not, the measurement system might need to be re-adjusted. Above that, the installation position and the overall setup might need an inspection.

Adjustment:

- Unload the measuring device*.
- Connect the multimeter (refer to chapter 4 "Terminal Assignment").
- Set the analogue output to 0 Volts.
- Load the measuring device (i.e. the transducer) at least 3 times with full load.
- Load the device with 80 % of its maximum load.
- Check if the analogue outputs comply with the load and is in the designated specs.
The analogue output value, corresponding to the load is to be set by a qualified person by using "Cal. G".

*Unloaded means with:

Force transducers: no applied force at all

Pressure transducers no pressure, except atmospheric influence

In this unloaded state, adjust the zero-point by using potentiometer "Cal. Z".

■ 5.2.1 Calculation of amplification determining resistor

The amplification is:

$$G_{\text{total}} = G_{\text{differential amplifier}} \times G_{\text{output stage}}$$

The amplification of the output stage is adjustable with the potentiometer P-02 (GAIN). The adjustable range is:

$$G_{\text{output stage}} = 9,5 \dots 10,5 \text{ Volts}$$

Calculation of the coarse amplification resistor R_G (applies for 10 Volts output):

$$G_{\text{differential amplifier}} = \frac{1000 \text{ mV}}{\text{Exc. (V)} \times \text{Signal} \left(\frac{\text{mV}}{\text{V}}\right)}$$

$$R_G = \frac{60 \text{ k}\Omega}{(G_{\text{differential amplifier}} - 4)}$$

Example:

Transducer: 2,5000 mV/V (0,0025V/V)

Excitation: 10,000 V

$$R_G = \frac{60 \text{ k}\Omega}{\left(\frac{1\text{V}}{10 \text{ V} \times 0,0025 \text{ V}} - 4\right)} = 1667 \text{ }\Omega$$

■ 6 Maintenance

The flawless function and calibration of the whole measuring system is to be checked regularly. This inspection is also necessary after every repair or change of any component of the measurement system.

■ 7 Old appliances disposal



According to European and German law, it is prohibited to dispose of old electronic devices by household waste, but must be collected and disposed of separately.

Amplifiers and measurement units manufactured and sold by Althen Mess- & Sensortechnik GmbH serve B2B purposes only. Therefore, those old appliances must not be given to the communal disposer, but must be given back to the seller or disposed of properly. If you need any further information, please contact your local authorities.

These measures serve to protect the environment and allow recycling and recovery of valuable materials. Furthermore, do electronic devices contain substances that may cause damage to the environment if burned or dumped with normal household waste.

■ Appendix

■ Datasheet

Number of measuring channels:	1 (full bridge resistance > 300 Ω)	
Supply voltage:	10 ... 18 VDC 18 ... 30 VDC	Electronic protected against reversal voltage
Isolating proof voltage input to output:	200 V with set JP2	Higher isolated proof voltage on request
Power consumption:	max. 3 W	
Strain gauge excitation supply:	2,5 VDC / 5 VDC / 10 VDC	
Analogue output	0 ... 10 V / ±10 V	max. 1 mA (short-period short-circuit proof)
Limit frequency (-3 dB):	1 kHz	
Input impedance:	>3 MΩ	
Max. input sensitivity:	25 mV/V at +10 VDC excitation supply	
Non-linearity:	±0.05 % FSO	
Electrical connection:	3 m cable type LiYCY (TP) 2 x 2 x 0,25 mm ² 5 pin connector. Binder series 712 or 423 (depending on the sensors cable)	
Housing:	aluminum diecast enclosure (IP20)	
Dimension (W x H x D):	92 x 31 x 38 mm	
Weight:	150 g	
Temperature, storage:	-20 °C ... +60 °C	
Temperature, operating:	-20 °C ... +50 °C	

■ Order designation

SG-NL...	Single channel strain gauge amplifier in an EMC-aluminum diecast enclosure (IP20)	
...-12E-...	Supply voltage: 10 ... 18 VDC	
...-24E-...	Supply voltage: 18... 30 VDC	
...-010	Analogue output: 0 ... 10 V	
...-B10	Analogue output: ±10 V	

■ Component diagram

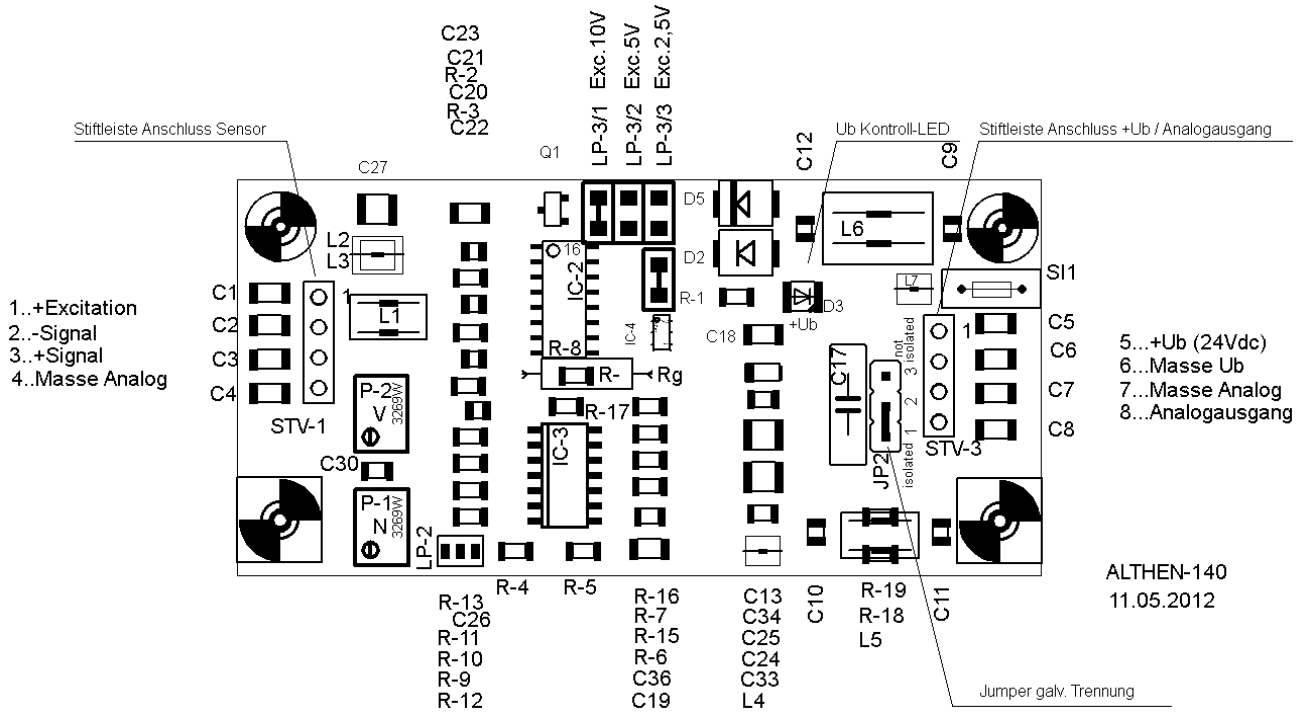

■ Housing dimensions

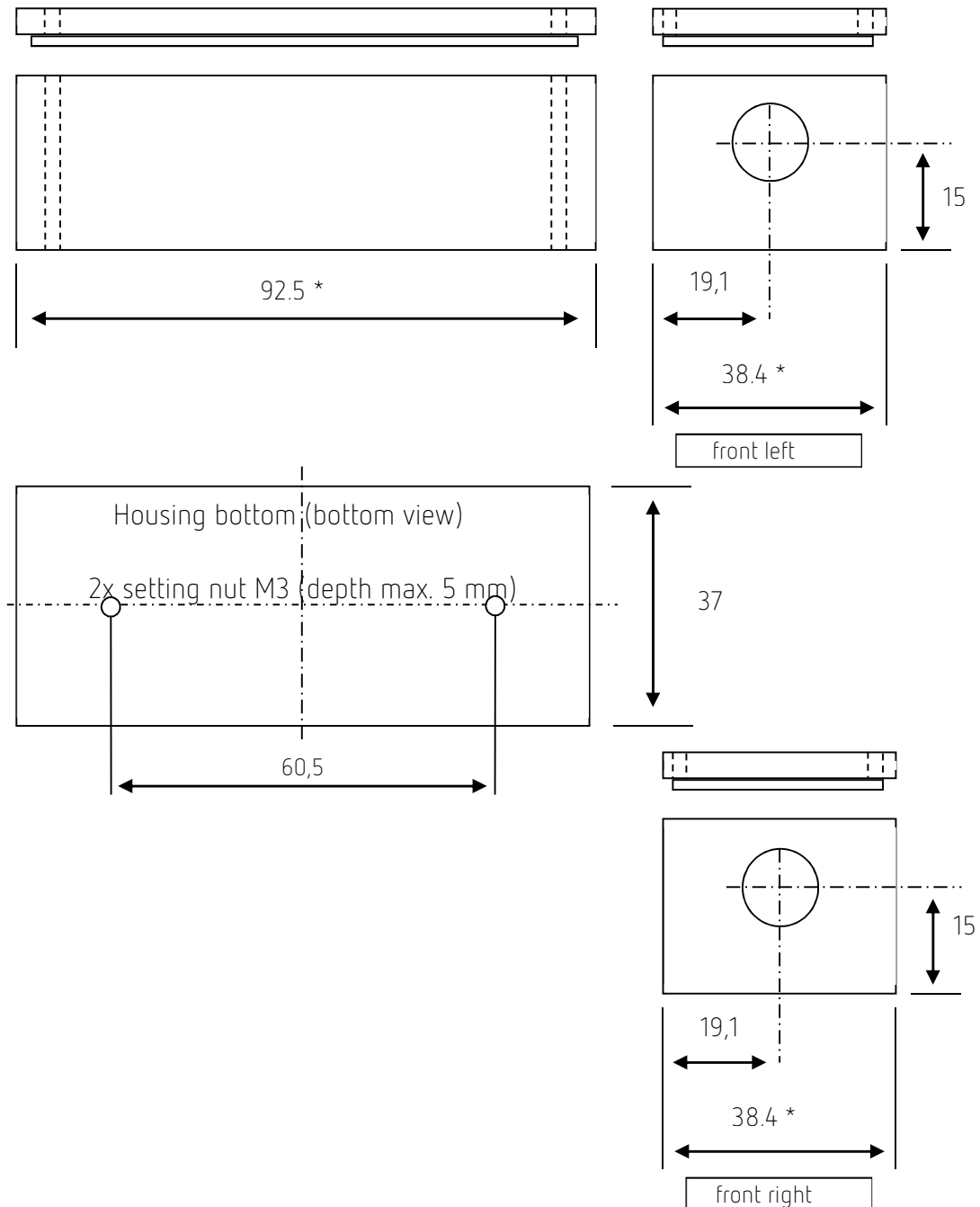

*conical

Subject to modifications.
All information describe our products in general form.